

## Organizing an international blind prediction contest for improving a guideline for the nonlinear finite elements analysis of concrete structures

de Boer, A.; Hendriks, Max; van der Veen, Cor; Belletti, Beatrice

**DOI**

[10.1201/9781315182964-66](https://doi.org/10.1201/9781315182964-66)

**Publication date**

2018

**Document Version**

Final published version

**Published in**

Computational Modelling of Concrete Structures

**Citation (APA)**

de Boer, A., Hendriks, M., van der Veen, C., & Belletti, B. (2018). Organizing an international blind prediction contest for improving a guideline for the nonlinear finite elements analysis of concrete structures. In G. Meschke, B. Pichler, & J. G. Rots (Eds.), *Computational Modelling of Concrete Structures: Proceedings of the Conference on Computational Modelling of Concrete and Concrete Structures* (pp. 545-552). CRC Press. <https://doi.org/10.1201/9781315182964-66>

**Important note**

To cite this publication, please use the final published version (if applicable). Please check the document version above.

**Copyright**

Other than for strictly personal use, it is not permitted to download, forward or distribute the text or part of it, without the consent of the author(s) and/or copyright holder(s), unless the work is under an open content license such as Creative Commons.

**Takedown policy**

Please contact us and provide details if you believe this document breaches copyrights. We will remove access to the work immediately and investigate your claim.

***Green Open Access added to TU Delft Institutional Repository***

***'You share, we take care!' - Taverne project***

**<https://www.openaccess.nl/en/you-share-we-take-care>**

Otherwise as indicated in the copyright section: the publisher is the copyright holder of this work and the author uses the Dutch legislation to make this work public.

# Organizing an international blind prediction contest for improving a guideline for the nonlinear finite elements analysis of concrete structures

A. de Boer

*Ane de Boer Consultancy, Arnhem, The Netherlands*

M.A.N. Hendriks

*Delft University of Technology, Delft, The Netherlands*

*Norwegian University of Science and Technology, Trondheim, Norway*

C. van der Veen

*Delft University of Technology, Delft, The Netherlands*

B. Belletti

*University of Parma, Parma, Italy*

**ABSTRACT:** At the previous EURO-C conference, a guideline for nonlinear finite analysis and safety assessment of concrete structures was presented. This guideline is a results of a cooperation between the Delft University of Technology, the University of Parma and the Dutch Ministry of Infrastructure and the Environment. The nonlinear finite element results of a workshop around shear failure, held in Rotterdam in 2007, was the starting point for the development of a guideline for nonlinear finite element analysis. The scatter of the results presented in Rotterdam was considered as too large; knowledge of nonlinear finite element analysis of concrete structures should be controlled better in order to make nonlinear finite element analysis an accepted method. In 2012 the first version of the guideline that focussed on girder structures was published.

In 2014, at the concrete structures laboratory of the Delft University of Technology, four almost similar prestressed girders were tested till the ultimate limit load level. This was considered as an opportunity to organise a contest to predict this ultimate load level at failure. The participants were asked to make use of the guideline. A workshop at the University of Parma gave the teams the opportunity to pitch their predictions. This paper presents the following topics: an overview of the content of the guideline, the gain of a controlled blind prediction contest and the main outcomes of the contest in Parma.

## 1 INTRODUCTION

At the Euro-C in 2014 in Sankt-Anton Austria the first edition of a guideline for the nonlinear finite element analysis (NLFEA) of concrete beams was presented together with an announcement of an international contest for predicting the ultimate limit load of prestressed girders. The aim of the international contest was to get more awareness of the guideline in the concrete mechanics society. The guideline was setup by using two FE codes; in the contest the use of other FE codes were anticipated. The contest was also a test to see if the scatter of the predicted results from the different teams was reasonably small. In a preceding workshop in 2007 in Rotterdam only participants from scientific research institutes were present. In the new contest also

practical engineering offices were invited explicitly. The Model Code 2010 and the EC2 code indeed give opportunities to apply nonlinear analysis for concrete structures in practical design and reassessment projects. An important aspect for the practical application was the introduction of the so-called safety formats in both codes. The proof of extra capacity of existing concrete structures by re-examination of these concrete structures with nonlinear analysis has contributed that many structures could remain in operation and be a part of the infrastructure network, instead of being demolished and replaced.

In parallel to the organization of the international contest the NLFEA Guideline was developed further. The application area was extended to reinforced slabs. Besides, all simulations of experiments that were used during the development of

the guideline were documented. This resulted in a set of validation examples for the guideline. All validation examples are reported now in a consistent way, including the process of developing the FE model, the analyses, as well as the reporting of the results. For the future, more validation examples are needed to get a finer coverage of failures of the bearing capacity of existing concrete structures and its failure modes.

## 2 CONTENT OF THE NLFEA GUIDELINE

### 2.1 *General*

The NLFEA Guideline includes chapters on Modelling, Analysis, Limit state verification and Reporting of results. In the following sections some items are described in more detail. The guideline has borrowed the layout of the ModelCode2010. In this format the right-hand side pages include the articles and the left-hand side pages include additional information about the articles.

### 2.2 *Finite elements for concrete*

Elements with quadratic interpolation of the displacement field should be used. Preferably a quadrilateral shape or a hexahedral shape should be used in 2D and 3D, respectively. For large slab structures, modeling with solid brick elements is not practical because of the large amounts of finite elements needed to accurately describe the stresses in the structure. Structural elements such as beam elements and (flat) shell elements can be used to model large-scale structures in cases it is not feasible to model with solid brick elements. However, these types of structural elements are not capable to model shear failure and additional post-analysis checks should be carried out to ensure that a shear failure mode is not overlooked. The preferred elements are also quadratic elements, such as 3-node beams in 2D and 3D, and 6-node triangular and 8-node quadrilateral shell elements for 2.5D analysis. So, models with a combination of structural elements and continuum elements can be considered.

### 2.3 *Constitutive models*

Material models, in a finite element context, specify the constitutive behavior (the stress-strain relationship) that is assumed for the materials in the structure. The material models are often simplified abstractions of the true material behavior.

For concrete, a total strain-based rotating crack or fixed crack model is preferred, based on linear-elastic properties, extended by tensile behavior, shear behavior, compressive behavior, tension-compression

interaction, compression-compression interaction and smearing softening relations using equivalent lengths.

For reinforcement, an elasto-plastic material model with hardening should be used.

### 2.4 *Convergence tolerances analysis*

The Newton-Raphson iteration method requires a criterion at which equilibrium is supposed to be achieved. In general, the unbalance forces will not be reduced exactly to zero but instead a tolerance has to be set at which convergence is achieved. The criterion is often a norm based on the unbalance force vector, the incremental displacement vector or a norm based on energy. The convergence criterion is often enhanced with a pre-defined maximum number of iterations to avoid excessive number of iterations. The latter, however, should not be considered a convergence criterion.

A suitable convergence criterion has to be used for determining equilibrium. Preferably an energy-norm in combination with a force-norm should be used; a norm based on displacements only should be avoided.

For the type of analyses for which these guidelines are intended, typically 0.01 and 0.001 tolerances are suggested for norms based on unbalance forces and energy norms respectively.

Load increments in which at least one of the two norms is satisfied can be considered as converged. Load increments which do not fully comply the convergence criteria might be still admissible, provided that they are followed by converged load increments and a plausible explanation for the temporarily non-convergence is provided.

### 2.5 *Reporting aspects*

Thoroughly planning a finite element analysis reduces risks of errors and time and thus costs. Also, the results of a finite element analysis should be reported in a standard fashion to reduce time and costs associated with (peer) reviewing and archiving an analysis. Generally accepted requirements for technical reports, like the consistent use of figure and table captions, consistent referencing to figures, tables, appendices and other reports, an effective structuring in sections and appendices should be followed strictly.

## 3 A BLIND PREDICTION CONTEST

### 3.1 *Initiative*

After the publication of the first draft of the NLFEA Guideline in May 2012, which was the

guideline solely dealing with (prestressed) reinforced beams, and after the guideline was in use for a few years, the DIANA Users Association took the initiative for organizing a prediction contest, in close cooperation with the Delft University of Technology and the Dutch Ministry of Infrastructure, Rijkswaterstaat. The contest marked the 30th anniversary of the Association. Four almost similar prestressed beams were to be tested in the second half of 2014 in the lab of the Delft University of Technology. The expected failure was shear force failure. The participants of this International Contest were challenged to predict the failure load. The results were to be presented and discussed in a special contest workshop, which was hosted by the University of Parma in November 2014.

### 3.2 Test setup

The test setup is given in the figure below. The loading jack will be positioned at a distance of 2950 mm from the centre of the support (support type B). The dimensions and material properties of the loading jack and the supports were given in more detail in an appendix, which is downloadable from the website of the Association. The four almost similar precast prestressed girders have been manufactured in May of 2012 and were used for other tests, which were not damaging the girders. The tests of the girders by Sebastiaan Ensink took place from the second half of August until October 2014 in the Stevin Laboratory of Delft University of Technology.

### 3.3 Blind predictions

The participants of the international contest had to provide the following predictions:

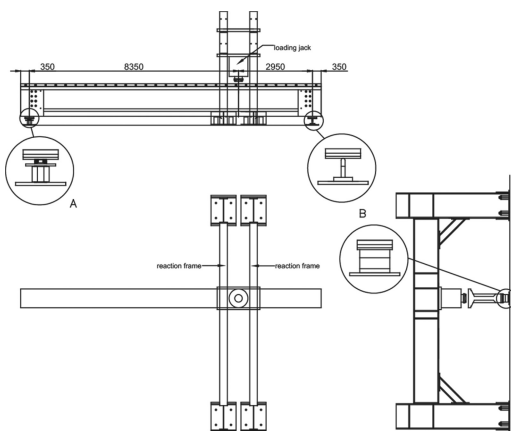

Figure 1. Test setup.

1. The maximum (and minimum) load at failure.
2. The failure mechanism.
3. The cracking pattern at SLS (defined as 75% of the failure load) and ULS.
4. The crack width at SLS.
5. The load-displacement diagram at the position of the load.

### 3.4 Properties of the T-shaped girders

Two almost similar types of T-shaped girders were tested, labelled as mid and edge girders. They differ

Table 1. Overview drawings girders.

Girder code	Drawing numbers			
CODE101	100	S100	101	
CODE201	200	S200	201	
CODE301	300	S300	301	W100
CODE401	400	S400	401	

Table 2. Some basic data of T-shaped bridge girders.

Girder code	Type	Height [mm]	Width of top flange [mm]	Length [mm]	Concrete class	Self-weight of girder [kN]
CODE101	mid-beam	1300	750	12000	C53/65	110.75
CODE201	edge beam	1300	875	12000	C53/65	114.55
CODE301	mid-beam	1300	750	12000	C53/65	110.80
CODE401	edge beam	1300	875	12000	C53/65	114.65

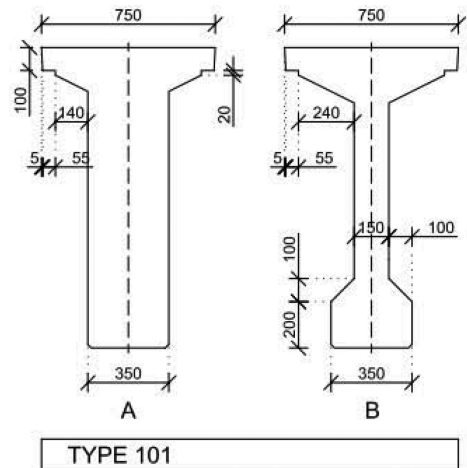
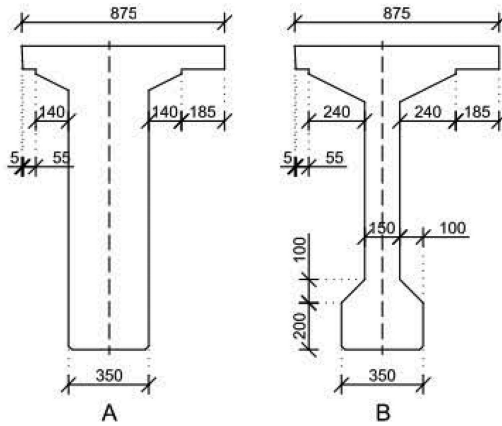

Figure 2. Dimensions of the mid girder 101.



TYPE 201

Figure 3. Dimensions of the edge girder 201.

only by width of the top flange (750 mm versus 875 mm). All other properties such as concrete class, amount of prestressing and reinforcement are the same for each girder. Table 1 gives an overview of the four girders.

Table 2 lists the main dimensions and the concrete class. All material properties are designated according to Eurocode 2. Figures 2 and 3 show the cross-sectional dimensions of the mid and edge girders.

In the top flange, in transverse direction, empty ducts are present ( $\text{Ø}45$  mm c.t.c. 400 mm). At the ends of the girder in the thickened web also some empty ducts are present ( $8 \times \text{Ø}65$  mm).

### 3.5 Prestressing

Each girder is pre-tensioned using 24 strands  $\text{Ø}15,7$  mm ( $150 \text{ mm}^2$  per strand) with steel type FeP1860. The measured force per strand before casting of the concrete is 214 kN.

This force needs to be reduced ( $\sim 8\text{--}9\%$ ) in order to take into account the elastic deformation of the cross-section to determine the actual prestressing force at  $t = 0$ .

The mean cubic concrete strength at time of prestressing was determined at  $f_{\text{cm,cube}} = 54 \text{ N/mm}^2$ .

### 3.6 Reinforcement

The shear reinforcement, Figure 4, consist of stirrups ( $\text{Ø}10$  mm) with a c.t.c. distance of 120 mm and 80 mm (except for thickened web at both ends) see appendix B (downloadable from the website of the Association), drawings 101, 201, 301, 401 and W100.

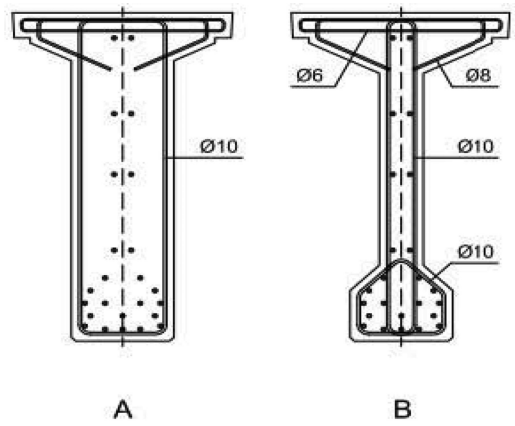

TYPE 101

Figure 4. Reinforcement layout of girder 101.



Figure 5. Test setup in the lab.

For the manufacturing of the reinforcement cage only some light longitudinal reinforcement is present ( $10 \times \text{Ø}8$  mm). All reinforcement has steel type B500A ( $\leq \text{Ø}6$ ) and B500B ( $\geq \text{Ø}8$ ). Figure 5 shows the four girders before testing.

### 3.7 Concrete properties

The mean cubic concrete strength ( $f_{\text{cm,cube}}$ ) is continuously monitored and checked by the manufacturer. The mean cubic compressive strength after 28 days is  $f_{\text{cm,cube}} = 83 \text{ N/mm}^2$  and the characteristic cubic compressive strength is  $f_{\text{ck,cube}} = 77 \text{ N/mm}^2$ . The concrete mix is a self-compacting concrete.

Also six  $150 \times 150 \times 150 \text{ mm}^3$  cubes have been tested after about 9 months. Three cubes were tested in compression and three in splitting. The results are given in the Table 3 below. The testing

Table 3. Six Concrete cube samples.

Number	Test	$f_{cm,cube}$ [N/mm <sup>2</sup> ]	$f_{cm,sp}$ [N/mm <sup>2</sup> ]	Age [days]
1	compression	89.92		273
2	compression	91.62		273
3	compression	87.95		267
4	splitting		6.15	273
5	splitting		6.37	273
6	splitting		6.39	273

of the girders took place from the second half of August until October 2014.

### 3.8 Workshop in Parma

The Shear Force Workshop, with contributions of the participants, took place in the first week of November 2014 at the University of Parma. Beatrice Belletti and Cecilia Damoni, of this university, were strongly involved in the validation of the guideline, in close cooperation with Jan Rots, Max Hendriks and Joop den Uijl from the Delft University of Technology. The deadline for submitting the results was originally set to 15th August, and was later extended till the 1st September.

In the workshop every team presented their results in a pitch of 5 minutes. After all team presentations, there was an presentation which summarized all predictions together with the lab results. At the end of the workshop, there was a winner.

## 4 RESULTS FROM THE CONTEST

Unfortunately only two of the four tests were executed at the moment of the workshop. The failure mode was not a real shear force failure. The influence of the ducts of the transverse prestressing, coming from previous tests on the complete structure clearly influenced the failure mode. Consequently, a revision of the test setup was necessary for the remaining two girders.

All information on the presence of these ducts was available for all participants, All teams were in a position to take this in consideration.

Figures 6 and 7 show the failure of the beams.

In total 14 teams, all from Europe, were present at the workshop at the University of Parma; more than expected by the organization. Eight different countries were represented and 6 different FE packages were used to predict the failure of the girders.

All of the teams presented their results in a condensed format. Aspects like dealing with lacking information and comments or suggestions for improvements of the guideline were presented. This

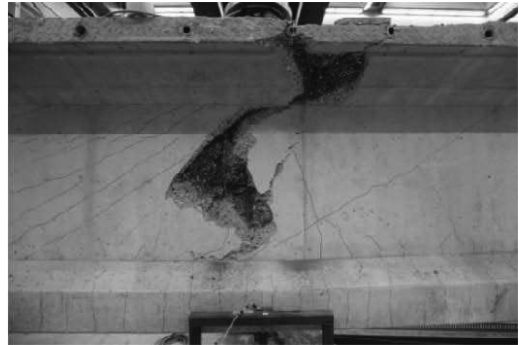

Figure 6. Side view of the failure location.



Figure 7. Top view of the flange.

information was used by the organizers and the authors of the guideline for updating the guideline.

The predictions of the failure load ranged from 1824 kN to 2854 kN, which is a 29% undershoot, respectively a 11% overshoot of the experimental result. The mean prediction was 2416 kN, which is 96% of the experimental value and the standard deviation of the predictions is 317 kN which is 13% of the mean prediction. There was a mix of 2D plane stress models and 3D solid models. Various assumptions were used to interpret 2D stress and strain behavior in 3D.

Two teams predicted a failure load which differed 1% from the experimental load of the girder in the lab. The additional questions about crack pattern, crack widths and expected failure mode, were taken into account to appoint the winner of the contest.

## 5 SUGGESTED IMPROVEMENTS OF THE GUIDELINE

As a results of the workshop the meshing articles in the guideline were refined. For modeling a stand-alone girder such as in the contest, separate

meshing recommendations for subdividing the flange and web are given.

Another observation is the under prediction of the tension stiffening effect and requires an improvement of the guideline. Slipping of reinforcement and an incomplete grouting process of ducts might also be addressed in the guideline. In the test unfilled ducts influenced the failure behavior of the girder. In the subsequent girder test 3 and 4, the ducts were filled with reinforcement bars to get a more realistic failure behavior.

A last improvement concerns the loading sequence. In experiments the load sequence is rather straightforward, the dead weight is followed by a force or uniform load configuration. In practice the design engineer has to deal with dead weights, asphalt, railing and other permanent loads. Additional loads include variable loads, like a uniformly distributed vehicle load and a vehicle tandem load. The permanent and variable loads have in a load combination different load factors. This means that the analyst will have to determine a sequence of load factors within the nonlinear analysis. All loads are incremented till a factor 1.0. Subsequently, all loads are incremented with the lowest additional (0.15) permanent factor (1.15). Finally an extra additional factor (0.10) till the maximum load factor of the variable load factor (1.25) is incremented. When using a safety format based on a global resistance factor an extra load factor of 0.3375 ( $= 0.27 \times 1.25$ ) is required for the variable load, according EC2 and MC2010.

The contest stressed the need of publishing all validation examples in a consistent way. Also, a need was identified to have a report with practical applications of structures based on the NLFEA Guideline.

## 6 IMPROVEMENTS OF THE GUIDELINE AFTER THE WORKSHOP

After the Parma workshop 5 reports were completed and submitted to the Ministry:

1. Updated NLFEA Guideline
2. Summary of validation experiments
3. Results for reinforced beams
4. Results for prestressed reinforced beams
5. Results for reinforced slabs

There is still a wish and a need to setup a report with results for practical structures. The next section gives an overview of the second report.

## 7 SUMMARY VALIDATION EXPERIMENTS

### 7.1 Model uncertainty

Table 4 gives an overview of the most important outcomes of the analyses i.e. the ultimate loading

Table 4. Overview of the case studies categorized per failure mode, showing the ratio of the experimental failure load to the numerical failure load (using mean material properties) and statistical properties of this ratio.

Failure mode	Case	Transversal reinforcement	$P_{max,exp.}/P_{max,NLFEA}$		
Bending	RB1	Yes	0.99		
	RB3	Yes	1.00		
	PB1	Yes	0.93		
	RB3A	Yes	1.14		
Flexural-shear	Yielding of shear reinforcement	Compressive	PB2	Yes	0.94
		shear	PB3	Yes	1.04
		shear	PB4	Yes	0.98
		Diagonal critical crack	RB2	No	0.95
		Shear	RS1	No	1.62
Shear failure in slabs*	Mixed mode	Shear	RS2	No	1.36
		Mixed mode	RS3	No	1.29
		One-way shear	RS4	No	1.33
		Mixed mode	RS5	No	1.33
			<b>Mean</b>		1.15
	<b>CoV</b>		0.19		

capacity. The cases are categorized per failure mode and show the presence of transversal reinforcement. The member name corresponds to the names as used in the titles of the chapters of other parts of the validation: reinforced beams (RB), prestressed beams (PB) and reinforced slabs (RS). The analyses of reinforced slabs have resulted in shear failure mechanisms of a complex nature being typically a combination of one and two-ways shear. Full details have been given in the respective chapters. The table shows the ratio between the maximum experimental load and the resulting maximum load according to the nonlinear finite element analyses with mean properties of material applied.

The ratio of the experimental failure load to the numerical failure load (using mean material properties) is a standard way of defining the modelling uncertainty. Safety formats for NLFEA are used to ensure a certain safety level. Within these safety formats, material uncertainty and geometrical uncertainty are usually accounted for directly whereas all other uncertainties are accounted for by the modelling uncertainty. The sources of the modelling uncertainty comprise both the inherent variability of the experiments and the accuracy of the nonlinear finite element models.



Table 5. Statistical properties of the modelling uncertainty per failure mode.

Failure mode	Mean	CoV
Bending	0.97	0.04
Flexural shear in beams	1.01	0.08
Shear in slabs	1.39	0.10
All	1.15	0.19

The table shows a mean value of 1.15 (i.e. on the “safe side” of 1.00) and a coefficient of variation (i.e. the standard deviation divided by the mean value, denoted as CoV) of 0.19. Due to insufficiency of references concerning a similar subject, it is difficult to compare and verify the obtained numbers. In the available references the following can be found. Engen et al. (2016) presents similar values, but for a different modelling approach which is more suited for large scale analyses (with relatively large elements). Schlune et al. (2012) investigated the modelling uncertainty by studying the statistics of various round robin analyses results, i.e. the results of international blind prediction competitions. They reported values of the CoV in the range of 0.03 to 0.39.

As indicated by Schlune, it is reasonable to distinguish easy cases from relatively difficult modelling cases. The round robin analyses usually fall in the latter category, including over-reinforced beams, shear panels and slabs. With this in mind, we calculate the properties of the modelling uncertainty ratio per failure mode. This is presented in Table 5.

We immediately emphasize that the statistics in this table are based on very few case studies. However, although the statistical significance of these properties of the modelling uncertainty is questionable, the table shows that the “difficult cases” are the slabs failing in shear. Following the current guidelines, they give a relatively high coefficient of variation (0.27) in combination with a “safe” mean of 1.35.

### 7.2 Comparison of the design resistance using different levels of approximation

Table 6 summarizes the design resistances. It distinguishes analytical models following the Eurocode and the *fib* Model Code 2010. For the Model Code 2010, different levels of approximations (LoA’s) have been considered, where applicable.

The highest level IV in Table 7 of approximation employs nonlinear numerical simulations. Verification of the design resistance according to this method has been executed by means of three safety formats introduced in the Model Code 2010.

The last column in Table 7, shows that increasing the level of approximation indeed reveals an increase of the established design resistance. This

Table 6. Results analytical models.

Member	EC2 [kN]	MC 2010 [kN]		
		LoA I	LoA II	LoA III
RB1	181			
RB3	99			
PB1	1097			
RB3A	85.9	57.67	69.2	97.65
PB2	3859	3275	3968	3968
PB3	668.4	596	761.6	998
PB4	625.4	–	548.8	548.8
RB2	52	35.2	59	–
RS1	43.28			
RS2	636.7	425.4	536.3	–
RS3	232.6	146.3	282.2	–
RS4	224	133	272.6	–
RS5	235.7	157.7	289.3	–

Table 7. Results using different safety formats for LoA IV.

Member	MC 2010 LoA IV [kN]			$\frac{P_{Rd, LoA IV}}{P_{Rd, min}}$ / $\frac{P_{Rd, LoA IV}}{P_{Rd, max}}$	
	GRF	PF	ECOV		
RB1	190	193	203	1.12	1.12
RB3	116	115	120	1.21	1.21
PB1	1352	1376	1514	1.38	1.38
RB3A	110	114	119	2.06	1.22
PB2	4639	4774	5391	1.65	1.36
PB3	1549	1857	1952	3.28	1.36
PB4	809	589	874	1.59	1.4
RB2	54	56	57	1.62	0.97
RS1	–	–	–	–	–
RS2	785	917	890	2.09	1.4
RS3	502	582	588	4.0	2.1
RS4	521	613	607	4.0	2.23
RS5	610	726	677	4.29	2.34

column shows the ratio of the highest LoA IV design resistance to the lowest analytical design resistance.

## 8 CONCLUSION

The impact of the international contest on the further development of the guidelines is substantial. The enthusiastic presentations of blind prediction results at the workshop in a competitive setting, stimulates further research.

## ACKNOWLEDGEMENT

The authors wish to thank the Dutch Ministry of Infrastructure and the Environment (Rijkswaterstaat) for financing this research work.

## REFERENCES

- CEN 2005. Eurocode 2: Design of Concrete Structures – Part 1-1. General Rules and Rules for buildings, EN-1992-1:2005, Brussels, Belgium: Comité Européen de Normalisation.
- de Boer, A., M.A.N. Hendriks, J.A. den Uijl, B. Belletti, C. Damoni 2014. *Nonlinear FEA Guideline for modeling of concrete infrastructure objects*, EURO-C 2014, St. Anton, Austria, pg 977–985.
- Engen, M., Hendriks, M.A.N., Overli, J.A. & Aldstedt, E. (2015). Solution strategy for non-linear finite element analyses of large reinforced concrete structures. *Structural Concrete*, 16(3), 389–397.
- fib 2012. ModelCode 2010 Final Draft, Lausanne, International Federation for Structural Concrete (fib).
- Hendriks, M.A.N., A. de Boer, B. Belletti, “Guidelines for Nonlinear Finite Element Analysis of Concrete Structures”, Rijkswaterstaat Centre for Infrastructure, Report RTD:1016-1:2017, version 2.1.1, 2017 (to be published by Rijkswaterstaat).
- Hendriks, M.A.N., A. de Boer, B. Belletti, “Validation of the Guidelines for Nonlinear Finite Element Analysis of Concrete Structures – Part: Overview of results”, Rijkswaterstaat Centre for Infrastructure, Report RTD:1016-2:2017, version 1.0, 2017 (to be published by Rijkswaterstaat).
- Hendriks, M.A.N., A. de Boer, B. Belletti, “Validation of the Guidelines for Nonlinear Finite Element Analysis of Concrete Structures – Part: Prestressed beams”, Rijkswaterstaat Centre for Infrastructure, Report RTD:1016-3B:2017, version 1.0, 2017 (to be published by Rijkswaterstaat).
- Hendriks, M.A.N., A. de Boer, B. Belletti, “Validation of the Guidelines for Nonlinear Finite Element Analysis of Concrete Structures – Part: Reinforced beams”, Rijkswaterstaat Centre for Infrastructure, Report RTD:1016-3A:2017, version 1.0, 2017 (to be published by Rijkswaterstaat).
- Hendriks, M.A.N., A. de Boer, B. Belletti, “Validation of the Guidelines for Nonlinear Finite Element Analysis of Concrete Structures – Part: Slabs”, Rijkswaterstaat Centre for Infrastructure, Report RTD:1016-3C:2017, version 1.0, 2017 (to be published by Rijkswaterstaat).
- Schlune, H., Plos, M., Gylltoft, K. (2012). Safety formats for non-linear analysis of concrete structures. *Magazine of Concrete Research*, 64(7), 563–574.