

Control of hybrid ship drive systems

Grimmelius, HT; de Vos, P; Krijgsman, M; van Deursen, E

Publication date

2011

Document Version

Accepted author manuscript

Published in

COMPIT 2011 - 10th Conference on COMPuter and IT applications in the maritime industries

Citation (APA)

Grimmelius, HT., de Vos, P., Krijgsman, M., & van Deursen, E. (2011). Control of hybrid ship drive systems. In E. vd Noordaa (Ed.), *COMPIT 2011 - 10th Conference on COMPuter and IT applications in the maritime industries* (pp. 1-14). Technische Universität Hamburg-Harburg.

Important note

To cite this publication, please use the final published version (if applicable). Please check the document version above.

Copyright

Other than for strictly personal use, it is not permitted to download, forward or distribute the text or part of it, without the consent of the author(s) and/or copyright holder(s), unless the work is under an open content license such as Creative Commons.

Takedown policy

Please contact us and provide details if you believe this document breaches copyrights. We will remove access to the work immediately and investigate your claim.

Control of Hybrid Ship Drive Systems

Hugo Grimmelius, Delft University of Technology, Delft/The Netherlands,

h.t.grimmelius@tudelft.nl

Peter de Vos, Delft University of Technology, Delft/The Netherlands, p.devos@tudelft.nl

Moritz Krijgsman, Alewijnse Marine Technology, Nijmegen/The Netherlands,

b.krijgsman@alewijnse.nl

Erik van Deursen, Alewijnse Marine Technology, Nijmegen/The Netherlands,

e.w.vandeursen@student.tudelft.nl

Abstract

Stricter regulations on emissions force ship owners and designers to come up with new solutions for ship propulsion systems. Hybrid drive systems consisting of prime movers and batteries, like in the Toyota Prius, show great potential, especially in special ships like harbour tugs. Economic and environmental performance of such systems strongly depends on the way it is controlled. Dynamic computer models of system components were built to compare different system lay-outs and different control strategies and thus support the ship system designer with design decisions. A combination of fuzzy rule-based and optimization-algorithm control offer the best results. The modeling method, the different simulations, the optimization methods and resulting consequences for the ship system design are the main topics of this paper.

1. Introduction

Concerns about the sustainability of the currently used, fossil fuel dependent power systems (in ships) drive authorities to enforce stricter regulations on emissions. These stricter regulations force ship owners, and thus ship designers, to re-evaluate their designs of ship propulsion and powering systems. In the car industry this issue is addressed in different ways by different car producers, but one of the possibilities that has been realized is application of hybrid drive systems, e.g. Toyota Prius.

Thus the question can be raised whether or not it is sensible, from an economic as well as an environmental perspective, to apply this type of technology in ships as well. This depends mostly on the operational profile of the ship. It is argued that ships with a power demand that consists of significant, short-term peaks or long periods of very low load benefit the most of hybrid system technology. Examples of ship types that satisfy this description are yachts, dredgers, tugs, offshore support vessels, cruise ships and other complex specials. The reason why, and what design choices need to be made in hybrid system design for ships is explained in the section on hybrid system design and application.

Note that in this paper systems that contain one or more prime movers (e.g. diesel engines) and devices that can store a significant amount of energy (e.g. batteries) are considered hybrid (drive) systems. This definition of hybrid system is in contrast to for instance a ship that is equipped with power kites, which would also be referred to as utilizing a hybrid (propulsion) system.



Fig.1: Typical harbour tug: Damen ASD-tug 2810 'Smit Elbe'

As control of hybrid systems is new in shipping and relatively difficult in comparison to control of conventional ship drive systems, further sections will focus on that subject. The fact that control

requires more attention in ship system design calls for a new mind-set of marine system designers. The control strategy contains “switching points” that have a large impact on the fuel efficiency of a hybrid system. A proposition is made in this paper for optimal control, i.e. resulting in the best fuel efficiency, of a hybrid system consisting of diesel engines and batteries.

2. Hybrid system design and application

Marine diesel engines normally operate most efficiently at 70 – 85% nominal load. This is the reason an Engine Margin (EM) is chosen that distinguishes between Continuous Service Rating (CSR) and Maximum Continuous Rating (MCR) of an engine when it is matched to a propeller in merchant ship design. This method works very well for typical freighters that operate at design speed for the majority of their lifetime. In their case it makes sense to speak of typical service conditions, to which the engine and propeller can be tuned. But for other, more complex ships it is usually harder to define typical service conditions or at least a distinction is made between different operational modes during service. Each mode sets different requirements to the power system of the ship but the total installed power during complex special design is usually dictated by the operational mode with the highest power requirement. This leads to frequent part load operation of the engines when the ship is operating in another mode than high-power mode. It is mainly in these cases that hybrid technology offer significant opportunities to reduce fuel consumption and emissions.

A good example is the operational profile of a typical harbour tug, which contains three operational modes; moored at quay, transit and assist. All three modes occur frequently but typically the high-power mode (assist) occurs only for very short durations, yet it dictates the total installed power as the required bollard pull is the most important aspect of tug design. In Fig. 2 the difference in operational profile between a typical freighter and a tug is shown qualitatively. The propulsion power of a freighter is almost constant as it is sailing at a certain speed (design speed) for most of the time. The electric power demand is much smaller than the propulsion power and is therefore generated by separate generator sets or by power take-off. In case of the harbour tug the propulsion power varies and depends on the operating mode. A typical job is shown in the figure, starting with the tug being moored at the quay. During transit relatively little power is needed for propulsion as the tug is free sailing and usually is not in much of a hurry. During stand-by the tug is waiting for the ship to be assisted to enter the harbour and propulsion power is almost zero, i.e. very low load for propulsion engines. During assist temporarily a large amount of propulsion power is required to manoeuvre the assisted (larger) ship. Then the tug returns to its mooring place. Electric power regularly is in the same order of magnitude as propulsion power, which could be a reason to consider an all electric power system to obtain the usually associated benefits of all electric ships.

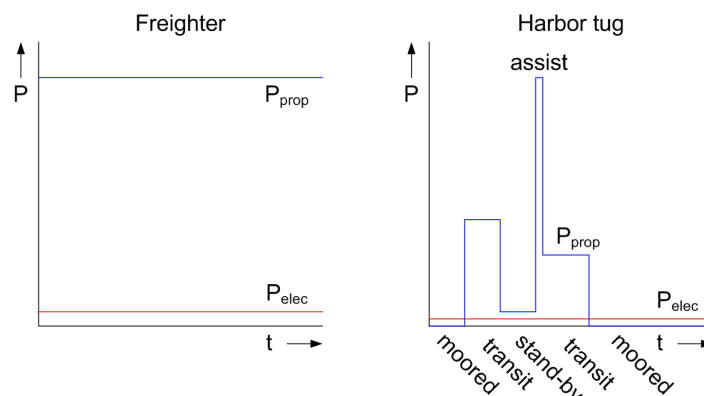

Fig.2: Qualitative comparison of operational profile of typical freighter (left) and harbour tug (right)

Especially in case of a harbour tug hybrid technology is very interesting as load levelling (peak shaving and dip filling) becomes possible. Peak shaving would then occur during assist; part of the required propulsion power would come from the battery, the other part from the engines. Dip filling could be used to increase the load of the engine during stand-by, when the load of the engines is very

low and thus the specific fuel consumption very high. This would mean the engine is better loaded and possible fouling does not occur. The extra power that is produced is stored in the battery, from which it is later extracted during assist or transit (or for auxiliary load).

The possibility of load levelling with hybrid systems results in an extra degree of freedom in system design, namely the hybridization degree, *Pede (2004)*, which was discussed in *de Vos (2010)*. The hybridization degree is the ratio between the installed power (maximum power of diesel engines) and the maximum required power of the ship: in case of the harbour tug the sum of the propulsion power during assist and auxiliary load. Because the battery can temporarily deliver power as well, it is no longer necessary to install as much power as is required at maximum, meaning the total installed engine power can be designed for average power instead of maximum power. Actually in hybrid system design there is a large interdependency between the load profile, the lay-out of the hybrid system, the control strategy and the size of the components (engines and batteries). Adjustment of one should lead to adjustment of the others during system design. In this paper we discuss the control strategy of a hybrid system, meaning that we should first know about the load profile, Fig. 2, but also about the size of components of and lay-out of the hybrid system. This is discussed in the next section.

3. Lay-out of engine room

First the lay-out of the current engine room on a typical harbour tug, Fig. 1, is presented in an Energy Flow Diagram (EFD, *Klein Woud (2002)*) in Fig. 3.

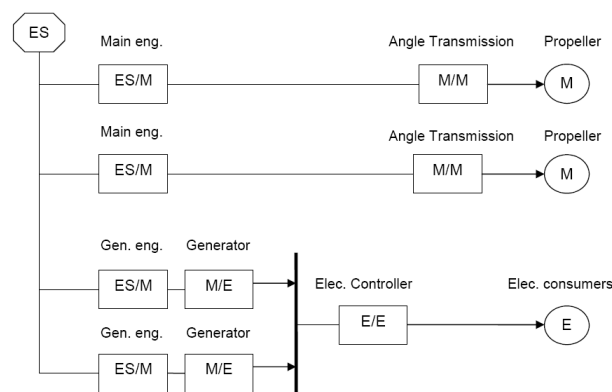

Fig.3: Energy Flow Diagram (EFD) of typical harbour tug “Smit Elbe”

The electric power generation system is separate from the propulsion system, which consists of two main engines (port and starboard), each mechanically driving a propeller through a gear. The main engines each have a maximum power output of 1865 kW. The generator sets produce a maximum power output of 105 kVA. As said the power of the main engines is determined by the set bollard pull which is only needed during assist. From the operational profile of a tug, Fig. 2, it can easily be seen that these engines will operate at part load the majority of the time.

Given the high, short-term peaks in power demand of a harbour tug a relatively low hybridization degree, meaning a large dependency on batteries, can be anticipated. However, with that the lay-out of the hybrid system is not yet known. The number of power generating units (diesel engines) and how components are connected (series, parallel, all electric, geared) still has to be chosen. As we focus on control strategy in this paper just one system configuration has been chosen (for now): the parallel hybrid system. This system is applied both on port and on starboard. An EFD is shown in Fig. 4.

This system resembles the parallel hybrid system that is used in typical hybrid cars, but in cars there is of course only one engine combined with one or more electric machines to drive the wheels. In the hybrid system of Fig. 4 a main engine can drive both a propeller and an electric machine. If this is the

case the ship would be sailing at a certain speed while the battery is being charged and the electric consumers are supplied with electric energy. In this situation both main engines could be running, splitting the load of propellers, electric consumers and battery charge, or one engine provides all power. When the tug is in ‘assist’ mode the propellers need maximum driving power; meaning that both main engines will be running, all of their power is transmitted to the propellers. At the same time the electric machines will act as motors and also provide power to the propellers. The electric machine obtains its power from the battery. A ‘silent mode’ is also possible with this system: none of the main engines are running and power needed for propulsion and electric consumers is provided by the battery. This can of course only be done for a limited amount of time depending on the capacity and initial state of charge of the battery.

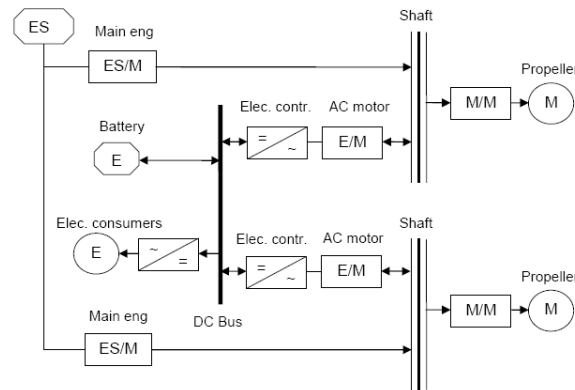

Fig.4: Energy Flow Diagram (EFD) of parallel hybrid system for a harbour tug.

More options are available, giving more flexibility in the way propellers are driven than the conventional system of the typical harbour tug, shown in Fig. 3. This flexibility in itself can be a reason for applying hybrid technology, but in case the system is well controlled it can also reduce overall fuel consumption, which of course makes it much more attractive. The energy management system should be able to decide which driving option results in the best efficiency and automatically switch to that mode. Of course this could best be done when upcoming events, or even the complete sailing profile is known up front. However, as this is very hard to realise (prediction of the future), a traditional feedback control system will have to be applied. Several options are available for feedback control, so which is the best energy management strategy and how do we test that?

4. Modelling of tug and system control

This section describes the simulation environment that is used for developing and evaluating the energy management strategy. Two different models are distinguished: (1) a ship model and (2) a control model. The ship model is used to analyse the performance and validate the control actions of the energy management strategy. It is a forward facing -or integrating model, i.e. a dynamic model. The ship model simulates the behaviour of the real ship as close as possible and has a flexible interface for connection of the control model. The control model simulates the energy management strategy that has been designed. The energy management strategy determines the optimal power split between the diesel engine and electric machine by means of optimization algorithm. The control model needs drastic component model reduction to fit in the specific optimization structure of the real-time implementation of the energy management strategy.

4.1. Ship model

The ship model accurately represents all relevant characteristics of a real ship and is used to evaluate the energy management strategies and their influence on the sailing behaviour of the ship. The model is based on the general ship modelling approach as applied by the marine engineering section at Delft University of Technology of which an overview is shown in Fig. 5.

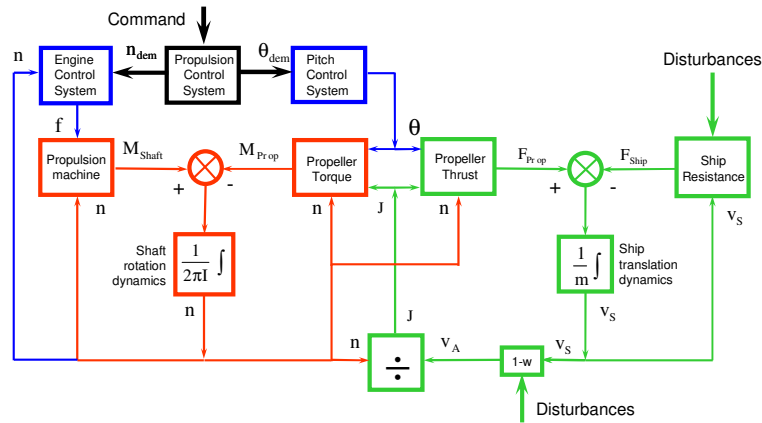

Fig.5: General ship propulsion model as presented in *Grimmelius (2007)*

The ship model is a forward facing -or- integrating model, i.e. a dynamic model. The inputs for the ship model are the speed settings for the diesel engine and electric machine and the pitch setting of the thruster. The output amongst others is the resulting ship speed and propeller torque and thrust. As said the model is based on the model as shown in Fig. 5, but some adjustments were necessary because of the presence of the electric machine and battery. Also a more advanced ship manoeuvring model has been developed for predicting the resistance. A schematic overview of the ship model is shown in Fig. 6. The left part of this overview resembles one side (port or starboard) of the EFD of the hybrid system shown in Fig. 4.

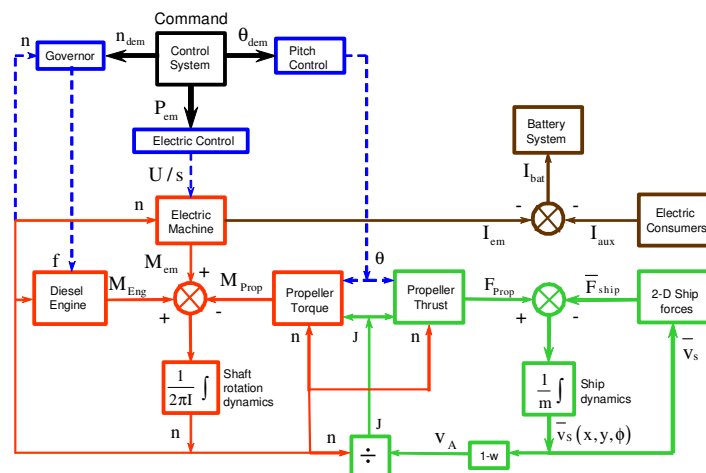

Fig.6: Schematic overview of ship model.

The model in Fig. 6 is driven by the control system sub-model. This includes the energy management strategy and contains the control model as mentioned above. It will be discussed in more detail later on.

The ship model also contains a model for the diesel engine and its governor. The diesel engine model determines the engine torque from the engine speed and the amount of injected fuel; the model is based on a five points Seiliger process. The governor model determines the amount of injected fuel on basis of the difference in engine speed and engine speed set point, which is supplied by the control model, *Shi, (2010)*.

The electric machine sub-model can operate in motor mode condition and generator mode condition. This model calculates the torque delivered or required by the electric machine, which is determined from the difference of the rotor speed and the rotor speed set point, *Trzynadlowski (1994)*.

The shaft rotation dynamics sub-model has three inputs: the torque delivered by the diesel engine and

electric machine and the torque required by the propeller. The required propeller torque will be reduced by the gearbox and is compared with the combined torque of the diesel engine and electric machine. The difference between the combined torque and the required torque of the propeller results in the rotational speed of the propeller shaft according to Newton's second law of rotational motion.

The propeller sub-model calculates the required torque and resulting thrust of the propeller on basis of the pitch setting, the shaft speed and the ship speed, *Shi (2010)*.

The ship dynamics sub-model shows some resemblance to the rotational dynamics sub-model. However in this model three degrees of freedom are considered instead of only one. The input for ship dynamics sub-model is the thrust delivered by the propeller and the forces resulting from the movement of the ship (including rudders). The net forces and moments give the ship movements using Newton's equations of motions.

In the 2D ship manoeuvring model, which is based on the model of *Inoue (1981)* the ship resistance is calculated as a function of speed and rudder angle. The ship resistance is a summation of the hull forces and the resistance produced by the thrusters.

The battery system sub-model calculates the State of Charge (*SoC*) and operational voltage of the battery as function of the supplied or received current, *van der Nat (1999); de Vos (2010)*.

The electric consumers sub-model dictates the amount of electric energy as required by the electric consumers on board the tug; this is the auxiliary load.

4.2. Control model

The control model determines the optimal power split between the diesel engine and the electric machine. This is achieved by making use of a optimization routine which minimizes a cost function of the hybrid drive train. The cost function used in the control model contains only relevant components of the hybrid drive train which have a large influence on the energy management strategy, i.e. the diesel engine, electric machine and battery. These components are already modelled in the ship model above, but these sub-models need drastic model reduction in order to fit into a certain optimization structure. The choice of a optimization routine in control engineering depends on different objectives: (1) the behaviour of the relevant models and (2) if a real time implementation of the controller is required, which of course is the case in for a practical application like a hybrid tug. The diesel engine fuel map can be approximated by a linear relation: Fig. 7.

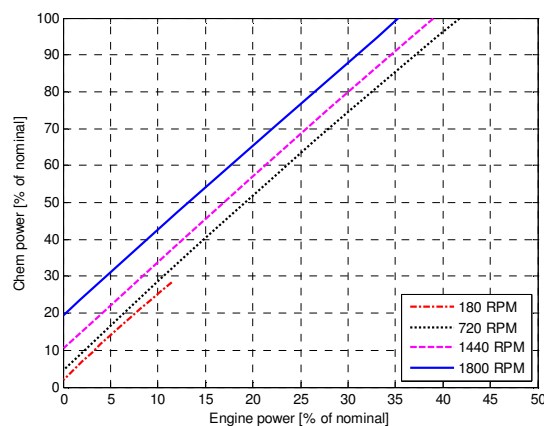

Fig.7: Chemical power P_f as function of engine power P_{eng}

The linear relation between delivered power and fuel consumption of the diesel engine is an important observation with regard to the energy management strategy. Similar characteristics as for the diesel

engine can be found for the electric machine and battery. Both components can be approximated with a linear relation. The relation between the electric power and mechanical power of the electric machine in motor and generator condition and the battery characteristic are both shown in Fig. 8.

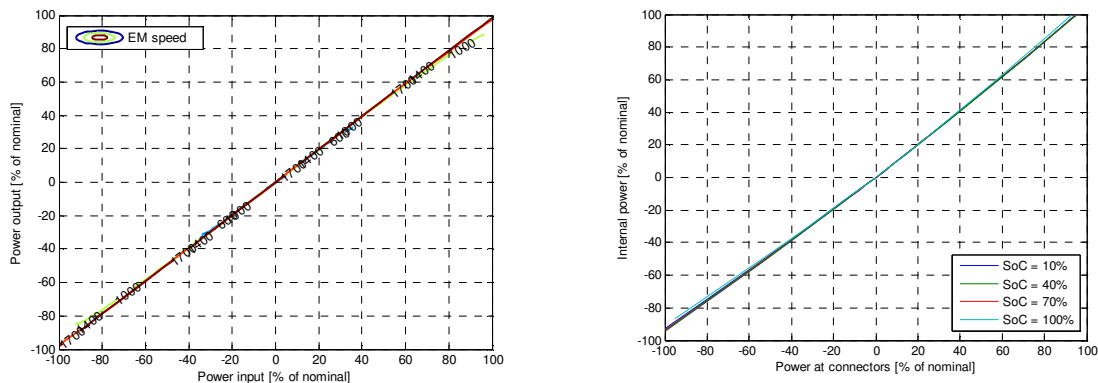

Fig.8: Electric machine input-output power relation (left); battery characteristic (right)

Because of the linear behaviour of the relevant drive train components the logical outcome is to search for a optimization routine with a linear structure. The routine that suits those requirements is the Linear Programming (LP) routine, *Hillier (2009)*. The Linear Programming is a collective of several linear optimization routines. The routine that yields good results concerning linear problems is the so called ‘Simplex’ method. The main advantage of the Simplex method is that it requires little computational power of a CPU, which is preferred because real time implementation is required. The main challenge is to fit the above described models into the Linear Programming structure. The easiest way to perform a linearization within the Matlab/Simulink environment is by means of look-up tables.

The input for the optimization routine is the power needed for the drive train (P_d), the power needed for the auxiliary load (P_{aux}) and the efficiencies of the diesel engine, electric machine and battery, depending on the operational point. The output of the optimization routine is the optimal internal battery power, which is constrained by the maximum power output of the diesel engine, electric machine and battery. Knowing the optimal internal battery power in terms of fuel cost the power split between the diesel engine and electric machine can be calculated mathematically. This procedure is calculated in sub-block ‘Power split’. The schematic overview of the control model is given in Fig. 9.

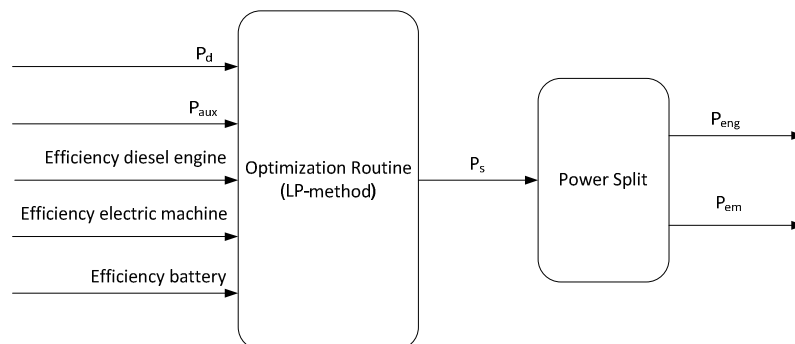

Fig.9: Schematic overview of control model

5. Control of hybrid system

The previous section laid the groundwork for the design of the energy management system. The mathematical models that are used for modelling the hybrid drive train show some important characteristics towards the energy management system. The goal of the energy management system is to find the optimal efficiency point of the complete hybrid drive train in terms of fuel cost. It can

happen that separate drive train components do not run in their optimal efficiency point but that the overall efficiency of the drive train is optimal. This can be achieved by constantly controlling the amount of power supplied by the diesel engine and the battery. The two power sources should always deliver at least as much power as is currently demanded.

Power delivery in the hybrid system starts with fuel that is injected in the diesel engine. The resulting mechanical power P_{eng} splits up into two directions: one part P_d goes to the drive train for ship propulsion, while the other part P_{em} goes to the electric machine. The electric machine provides electric power P_e for electric consumers (auxiliary load) P_{hl} but also takes care of charging the battery P_b . Contrary to the auxiliary load, the power flow to the other components can be positive or negative. A change in sign equals a change in direction of power. In the end, all power, except for losses, is used for ship propulsion or for electric consumers connected to the electric network. The lay-out of the hybrid system model is shown in Fig. 10.

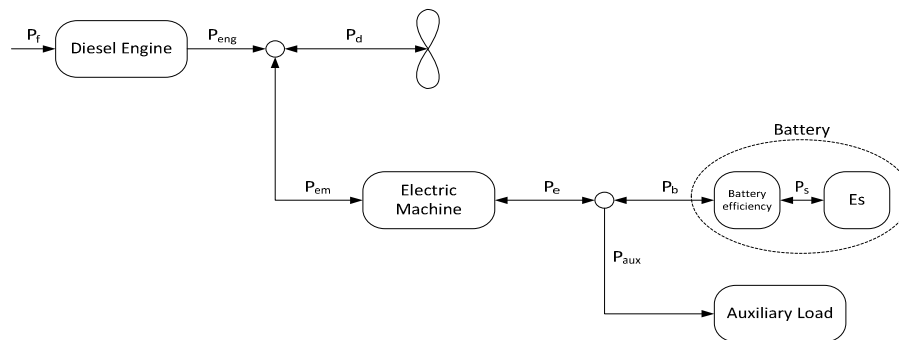

Fig.10: Parallel hybrid system model

Selecting the optimal strategy that results in the best overall efficiency has a lot of challenges. The difficulty lies in the fact that optimal solution has to be found in real time, so there is limited calculation time to find the optimal solution. The next difficulty is that the exact power demand during the next time step is not known in advance. Because of the lack of knowledge about the upcoming power demand, the energy management strategy has to react on the real time power demand and has also to anticipate what will happen during the next time step. A proven concept in the automotive industry to deal with this complex problem is to derive a mathematical formulation of the complete drive train and to construct a cost function from it. The cost function in combination with an optimization routine is referred to as Equivalent Cost Minimization Strategy (ECMS), *Guzzella (2005)*.

5.1. Objective function

The shape of the objective has a big influence on the results of the optimization problem. The minimum will be more difficult to find when the objective function has a non-convex character. Another difficulty with a non-convex function is that it can have multiple local minima, so the result of the optimization problem cannot be guaranteed to be the global minimum. The general idea behind the ECMS is that all energy that will be drawn from the batteries in the future has to be compensated by energy that is stored back in the batteries. This can be done using recuperated energy obtained from 'wind milling' or using excessive energy from the diesel engine and use the electric machine in generator mode to charge the batteries. Charging the batteries will result in extra fuel cost and power supplied by the batteries can be expressed in terms of 'equivalent fuel cost'. ECMS considers the energy drawn from the batteries not as costless energy but eventually it will cost some fuel in the future and vice versa, storing energy right now will save fuel in the future. Implementation of the extra fuel cost or saving into the objective function will be achieved by adding an extra penalty for the use of the battery power. The objective function when the electric machine operates in motor condition is as follow:

$$P_f = \frac{P_{eng}}{\eta_{eng}} \quad (1)$$

$$P_{eng} - P_d + P_{em} = 0 \rightarrow P_{eng} = P_d - P_{em} \quad (2)$$

Substitute Eq. (2) into Eq. (1):

$$P_f = \frac{P_d - P_{em}}{\eta_{eng}} \quad (3)$$

Adding the penalty function for the use of the battery results in the following objective function:

$$P_f = \frac{P_d - P_{em}}{\eta_{eng}} + \lambda P_s \quad (4)$$

$$-P_e + P_b - P_{aux} = 0 \rightarrow P_e = P_b - P_{aux} \quad (5)$$

The relation between the internal power and power measured at the connectors of the battery is defined as follow:

$$P_b = P_s \eta_{bat} \quad (6)$$

Substitute Eq. (6) into Eq. (5):

$$P_e = P_s \eta_{bat} - P_{aux} \quad (7)$$

The relation between the mechanical- and electrical power of the electric machine is defined as follow:

$$P_e \eta_{em} = P_{em} \rightarrow P_e = \frac{P_{em}}{\eta_{em}} \quad (8)$$

Therefore:

$$\frac{P_{em}}{\eta_{em}} = P_s \eta_{bat} - P_{aux} \rightarrow P_{em} = (P_s \eta_{bat} - P_{aux}) \eta_{em} \quad (9)$$

Substitute Eq. (9) into the Eq. (4):

$$\min P_f = \frac{P_d - \eta_{em} (P_s \eta_{bat} - P_{aux})}{\eta_{eng}} + \lambda P_s \quad (10)$$

$$\min P_f = \frac{P_d - \eta_{em} \eta_{bat} P_s + \eta_{em} P_{aux}}{\eta_{eng}} + \lambda P_s$$

Eq. (10) needs to be rewritten to fit in the Linear Programming (LP) structure. LP is a collective of different optimizations routines including the simplex method, a commonly used method for linear optimization problems. The Simplex method has a specific structure regarding the objective function. The formulation of the objective function in the specific Simplex structure is given by Eq. (11).

$$\min Z = cX \quad (11)$$

$$\min P_f = \left(-\frac{\eta_{em} \eta_{bat}}{\eta_{eng}} + \lambda \right) P_s + \frac{P_d - \eta_{em} P_{aux}}{\eta_{eng}}$$

The formulation of the objective function regards the operational point of the electric machine operates in generator mode and the excessive power of the diesel engine is used for charging the batteries.

$$P_f = \frac{P_{eng}}{\eta_{eng}} \quad (12)$$

$$P_{eng} - P_d + P_{em} = 0 \rightarrow P_{eng} = P_d - P_{em} \quad (13)$$

Substitute Eq. (13) into Eq. (12):

$$P_f = \frac{P_d - P_{em}}{\eta_{eng}} \quad (14)$$

Adding the penalty function for the use of the battery results in the following objective function:

$$P_f = \frac{P_d - P_{em}}{\eta_{eng}} - \lambda P_s \quad (15)$$

$$P_e - P_b - P_{aux} = 0 \rightarrow P_e = P_b + P_{aux} \quad (16)$$

$$P_e = P_{em} \eta_{em} \rightarrow P_{em} = \frac{P_e}{\eta_{em}} \quad (17)$$

$$P_s = P_b \eta_b \rightarrow P_b = \frac{P_s}{\eta_{bat}} \quad (18)$$

$$\min P_f = \frac{P_d + \frac{P_s + P_{aux}}{\eta_{bat}}}{\eta_{eng}} - \lambda P_s \quad (19)$$

Writing Eq. (19) in the specific LP structure:

$$\min P_f = \frac{P_d \eta_{bat} \eta_{em} + P_s + P_{aux} \eta_{bat}}{\eta_{bat} \eta_{em} \eta_{eng}} - \lambda P_s$$

$$\min P_f = \left(\frac{1}{\eta_{bat} \eta_{em} \eta_{eng}} - \lambda \right) P_s + \frac{P_d \eta_{bat} \eta_{em}}{\eta_{bat} \eta_{em} \eta_{eng}} + \frac{P_{aux} \eta_{bat}}{\eta_{bat} \eta_{em} \eta_{eng}} \quad (20)$$

$$\min P_f = \left(\frac{1}{\eta_{bat} \eta_{em} \eta_{eng}} - \lambda \right) P_s + \frac{P_d}{\eta_{eng}} + \frac{P_{aux}}{\eta_{em} \eta_{eng}}$$

The optimal solution is found by comparing both solutions of the two defined objective functions and selecting the one that yields the lowest solution, in other words the lowest fuel cost. Knowing the solution that yields the lowest fuel cost, the power split of diesel engine and electric machine can be determined mathematically. Since the optimization does not use any complicated operations the optimization routine is computationally not very demanding and can easily be implemented in a real time controller.

5.2. Constraints

The objective function is constrained in the actions it can take and has for this reason influence on the solution of the objective function. This section covers four constraints in total: peak power of the diesel engine, peak power of the electric machine, peak current of the battery during charging/discharging and the battery state of charge. All the constraints have to be rewritten into internal battery power P_s to corresponds with the above defined objective functions. The constraints need to be formulated in a certain structure where the objective function is subjected to linear constraints.

5.2.1 Diesel engine constraints

The diesel engine has physical limitations that constrain the actions the energy management can take. The constraint for the diesel engine is defined by the maximum and minimum amount of power it can produce:

$$0 \leq P_{eng} \leq P_{eng_max} \quad (21)$$

The above constraint needs to be rewritten as a function of internal battery power so it suits LP objective functions. The constraint for the engine peak power needs to be defined for two situations, the first situation where the electric machine operates in motor condition and the second situation

where the electric machine operates in generator condition.

For the first situation the constraint is:

$$P_{s_max} \geq \frac{P_{eng_max} - P_d + P_{aux} \eta_{em}}{-\eta_{bat} \eta_{em}} \quad (22)$$

$$P_{s_min} \leq \frac{-P_d + P_{aux} \eta_{em}}{-\eta_{bat} \eta_{em}}$$

For the second situation the constraint is:

$$P_{s_max} \leq \{(P_{eng_max} - P_d) \eta_{em} - P_{aux}\} \eta_{bat} \quad (23)$$

$$P_{s_min} \geq (-P_d \eta_{em} - P_{aux}) \eta_{bat}$$

5.2.2 Electric machine constraints

The electric machine has a similar constraint on the peak power as the diesel engine. The constraint for the electric machine is defined by a maximum and minimum amount of power it can produce:

$$0 \leq P_{em} \leq P_{em_max} \quad (24)$$

For the first situation the constraint is:

$$P_{s_max} \leq \frac{P_{em_max} + P_{aux} \eta_{em}}{\eta_{bat} \eta_{em}} \quad (25)$$

$$P_{s_min} \leq \frac{P_{aux} \eta_{em}}{\eta_{bat} \eta_{em}}$$

For the second situation the constraint is:

$$P_{s_max} \geq (P_{em_max} - P_{aux}) \eta_{bat} \quad (26)$$

$$P_{s_min} \geq -P_{aux} \eta_{bat}$$

5.2.3 Battery constraints

The constraint for the battery is defined as a maximum discharge or charge current. To express the maximum allowable current as function of internal battery power is more complicated as the two previous defined constraints. The battery power measured at the connectors is a function of the battery voltage and current. The relation can be defined by Ohms law:

$$P_b = UI \quad (27)$$

The maximum current during discharge condition is:

$$I_{discharge} \leq I_{bat_dis_max} \quad (28)$$

The maximum current during charge condition is:

$$I_{charge} \leq I_{bat_charge_max} \quad (29)$$

The constraints for the charge - and discharge current is obtained from the technical specifications of the battery manufacturer. The maximum allowable current as function of the internal battery power can now be expressed as follows. For situation one:

$$P_s \leq \frac{I_{bat,dis,max} \cdot U_{bat}}{\eta_{bat}} \quad (30)$$

For the second situation the following constraint applies:

$$P_s \leq I_{bat,charge,max} \cdot U_{bat} \eta_{bat} \quad (31)$$

5.2.4 Constraining SoC by controlling the equivalent weight factor λ

In the previous section all the constraints are defined concerning the different drive train components except for the constraint to keep the state of charge (SoC) of the battery within certain limits. It is not possible to define the SoC as function of the internal battery power. The strategy adopted here was recommended by *van Kessel (2007)*. It was applied as part of the control strategy for hybrid cars. The schematic overview is shown in Fig. 11.

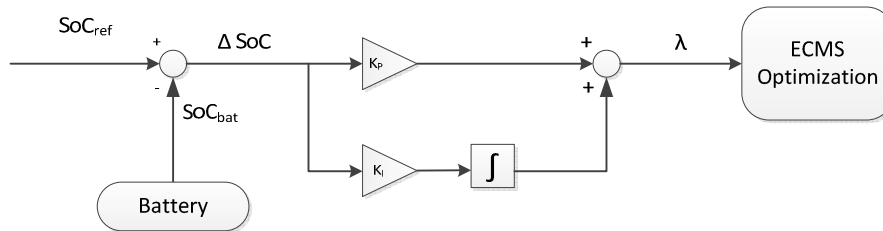

Fig.11: PI controller for approximation of λ .

A PI controller is introduced to keep track of the SoC by controlling the equivalent consumptions weight factor λ . If the equivalent weight is too large the optimization will be too conservative, resulting in low cycling over the batteries and too much use of the diesel engine. If the equivalent weight factor is too small the optimization will use the battery too aggressively, resulting in too much cycling over the battery, or even draining the battery fully. The influence of the equivalent cost factor on the SoC of the battery can be used to check whether an optimal value for λ is found or not.

6. Results

The number of variations for this kind of systems is unlimited. To show some of the key features of the system the preliminary results for two cases are presented: an artificial load case, Figs. 12 and 13, and a real load case based on measurements, Figs. 14 and 15. The hybridization degree for both cases is 64%, the battery has a rated capacity (100% to 0% SoC) equivalent to the energy needed to drive the electric machine at the nominal power during 1.5 h. The optimization update period is set at 50 s.

6.1 Artificial load

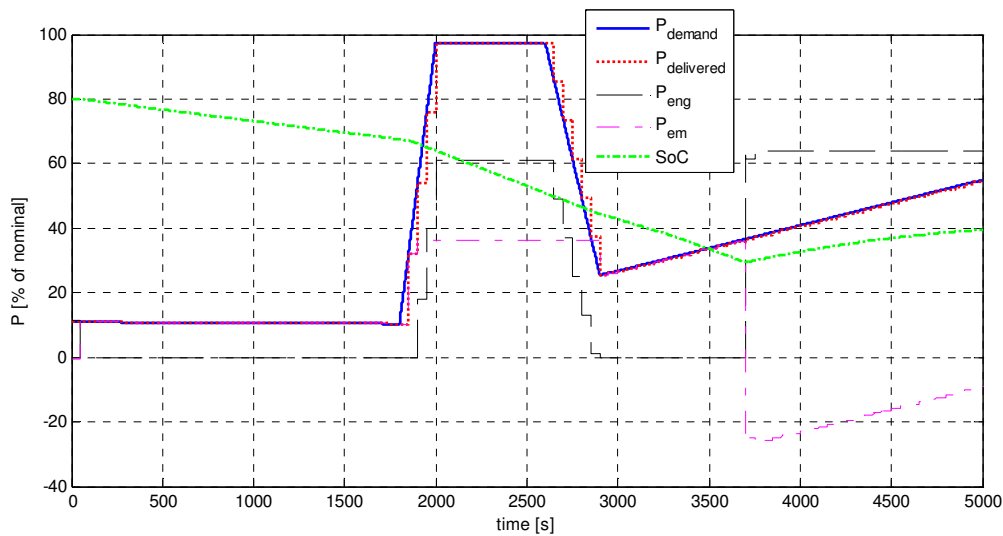

Fig.12: Artificial load cycle: powers and SoC

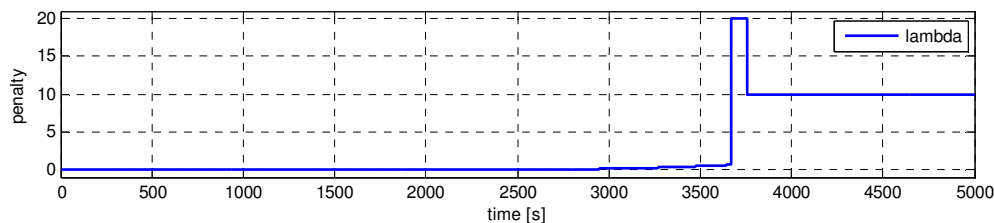

Fig.13: Artificial load cycle: equivalent weight factor λ

The load in this case starts low (12%) then increases rapidly to 95% at 2000 s. After a period of high power, power is reduced again and from 2800 s increases steadily. The battery is charged to 80% at the start. The system opts for electric drive, until at 1900 s the demanded power exceeds the electric machines capability and the engine is started. Because the battery is still well charged, λ remains low and the electric machine keeps delivering (now maximum) power, assisting the engine to meet the demanded power. The engine cuts out at 2800 s. At 3700 s the lower limit for SoC is reached and λ increases rapidly. As a consequence, the engine takes over and the electric machine is used as a generator to charge the battery. The available power for charging slowly decreases as the demanded power increases. The equivalent weight factor λ stays relatively high because the reference SoC is not reached yet.

The load sharing works fine, the only drawback with the chosen settings is the fact that in engine assist mode the load variations are handled by the engine rather than by the electric machine.

6.2 Realistic load

This case is a typical assist job for a harbour tug. During this trip the ship is in transit (with some manoeuvring between 900 s and 1500 s), Then the assist shows high power demands (3300 s – 4200 s), followed by another transit with the next assist starting around 7000 s. Here in two instances the battery is drained (around 1000 s and 6000 s), leaving the engine to deliver all demanded power. During the assist, both engine and electric machine are needed. During the (low power) transit between 1500 s and 3200 s the battery is charged sufficient to reduce λ to zero again. During the second transient this induces the system to select electric drive.

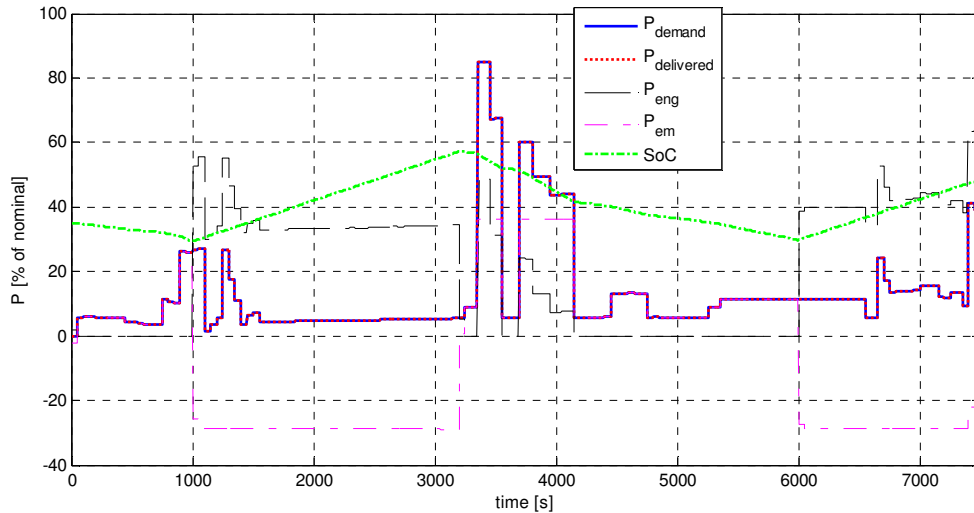

Fig.14: Real load case: powers and *SoC*.

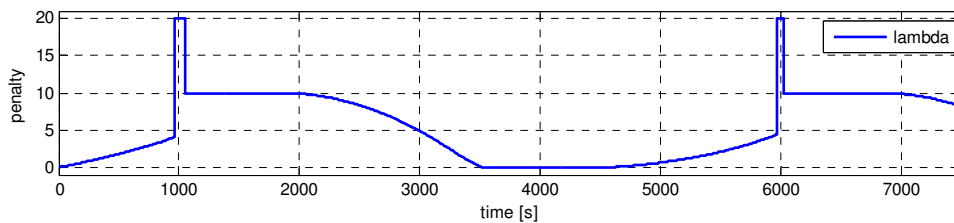

Fig.15: Real load case: equivalent weight factor λ .

6.3 Discussion

Many parameters were *not* varied in the results shown here. These include the settings for the λ controller, the associated *SoC* reference value, the limits of the *SoC* for the battery, the optimization update period etcetera. Initial tests show a coherent and logical response to all key parameters, opening the way for more detailed analysis.

7. Conclusion

A control method for hybrid ship drive systems has been presented in this paper. Preliminary results show great potential for real time implementation for ships equipped with a hybrid diesel engines – battery drive system. The influence of many of the parameters however still needs to be further investigated. Further research and experimentation are underway and will have to prove the practical applicability of this control system. A logical first extension of the approach is to include a controllable pitch propeller, adding an extra dimension to the optimisation problem.

References

VOS, P. de; VERSLUIJS, E.; STAPERSMA, D.; BARENDRECHT, I. (2010), *Application of dynamic models during design of a hybrid diesel fuelled PEMFC system with fuel reformer*, PRADS 2010, Rio de Janeiro.

GUZZELLA, L.; SCIARRETTA, A. (2005), *Vehicle propulsion systems*, Springer.

GRIMMELIUS, H.T.; MESBAHI, E.; SCHULTEN, P.J.M.; STAPERSMA D. (2007), *The use of Diesel engine simulation models in ship propulsion plant design and operation*, CIMAC 2007,

Vienna.

HILLIER, F.S. (2009), *Introduction to Operations Research*, McGraw-Hill.

INOUE, S.; HIRANO, M.; KIJIMA, K. (1981), *Hydrodynamic derivatives on ship manoeuvring*, International Shipbuilding Progress, Vol. 28.

KESSEL, J. van (2007), *Energy management for Automotive Power Nets*. PhD thesis, Technical University of Eindhoven.

KLEIN WOOD, J.; STAPERSMA, D. (2003), *Design of Propulsion and Electric Power Generation Systems*, IMarEST.

NAT, C.G.J.M. van der (1999), *A knowledge-based Concept Exploration Model for Submarine Design*, PhD thesis, Delft University of Technology, Delft University Press

PEDE, G.; IACOBAZZI, A.; PASSERINI, S.; BOBBIO, A.; BOTTO, G. (2004): *FC vehicle hybridisation: an affordable solution for an energy-efficient FC powered drive train*, Journal of Power Sources 125(2).

SHI, W.; GRIMMELIUS, H.T.; STAPERSMA, D. (2010). *Analysis of ship propulsion system behaviour and the impact on fuel consumption*, International Shipbuilding Progress, Vol. 57.

TRZYNADLOWSKI, A.M. (1994), *The Field Orientation Principle in Control of Induction Motors*, Kluwer Academic Publishers.