

Maximisation of energy recovery from waste activated sludge via mild-temperature and oxidative pre-treatment

Gonzalez, A.

DOI

[10.4233/uuid:d9943bd3-f988-4af2-bddf-f798a44a03e2](https://doi.org/10.4233/uuid:d9943bd3-f988-4af2-bddf-f798a44a03e2)

Publication date

2022

Document Version

Final published version

Citation (APA)

Gonzalez, A. (2022). *Maximisation of energy recovery from waste activated sludge via mild-temperature and oxidative pre-treatment*. [Dissertation (TU Delft), Delft University of Technology].
<https://doi.org/10.4233/uuid:d9943bd3-f988-4af2-bddf-f798a44a03e2>

Important note

To cite this publication, please use the final published version (if applicable).
Please check the document version above.

Copyright

Other than for strictly personal use, it is not permitted to download, forward or distribute the text or part of it, without the consent of the author(s) and/or copyright holder(s), unless the work is under an open content license such as Creative Commons.

Takedown policy

Please contact us and provide details if you believe this document breaches copyrights.
We will remove access to the work immediately and investigate your claim.

Maximisation of energy recovery from waste activated sludge via mild-temperature and oxidative pre-treatment

Dissertation

for the purpose of obtaining the degree of doctor
at Delft University of Technology
by the authority of the Rector Magnificus prof.dr.ir. T.H.J.J. van der Hagen,
chair of the Board for Doctorates
to be defended publicly on
Thursday 15 December 2022 at 10:00 o'clock

by

José Adrián GONZÁLEZ ORTEGA
Master of Environmental Engineering, Universidad Nacional Autónoma de México, México
born in Ensenada, México

This dissertation has been approved by the promotor.

Composition of the doctoral committee:

Rector Magnificus,	chairperson
Prof.dr.ir. J.B. van Lier	Delft University of Technology, promotor
Prof.dr.ir. M.K. de Kreuk	Delft University of Technology, promotor

Independent members:

Prof. dr. H.M. Jonkers	Delft University of Technology
Prof. dr. A Noyola Robles	Universidad Nacional Autónoma de México
Prof. dr. ir. L. Appels	Katholieke Universiteit Leuven, Belgium
Prof. dr. D. Brdjanovic	Delft University of Technology /IHE Delft, The Netherlands
Prof. dr. ir. L.C. Rietveld	Delft University of Technology, reserve member

Other members:

Dr. H. Carrère	French National Institute for Agriculture, Food, and Environment (INRAE), France
----------------	--



Printed by proefschrift-aio.nl

Cover by Dan Jrgi

Copyright ©2022 by Adrián González

ISBN: 978-94-93315-17-4

An electronic copy of this dissertation is available at TUDelft Repository.

Contents

Summary	9
Chapter 1. Introduction and thesis setup	11
1.1 Research setup and thesis outline	12
1.1.1 Objectives.....	12
1.1.2 Research questions	12
1.1.3 Outline.....	13
1.2 References	14
Chapter 2. <i>Veni</i> : Effects of pre-treatments on WAS: a review of causes, possibilities and limitations.....	15
Abstract.....	15
2.1 Introduction	16
2.1.1 Anaerobic biodegradability and biodegradation	16
2.1.2 Composition of waste activated sludge	17
2.2 Pre-treatment methods	21
2.2.1 Thermal pre-treatment <100 °C	21
2.2.2 Temperature phased anaerobic digestion (TPAD).....	24
2.2.3 Thermal pre-treatment ≥100 °C	25
2.2.4 Microwave pre-treatment	30
2.2.5 Freezing and thawing.....	33
2.2.6 Ultrasonic pre-treatment.....	35
2.2.7 Hydrodynamic cavitation, milling and homogenization	39
2.2.8 Chemical pre-treatments	40
2.2.9 Biological pre-treatment.....	48
2.3 Overall discussion	50
2.4 Conclusion.....	53
2.5 References	56
Chapter 3. <i>Vidi</i> : Effects of low-temperature thermal pre-treatment combined with H ₂ O ₂ on the bioconversion of WAS to methane.	72
Abstract.....	72
3.1 Introduction	73
3.2 Materials and Methods.....	74
3.2.1 Substrate, inoculum and pre-treatment.....	74
3.2.2 Anaerobic digestion	74

3.2.3 Analytical methods	75
3.2.4 Biodegradation and methane production rate	76
3.2.5 Design of experiments and statistical analyses	76
3.3 Results and discussion	77
3.3.1 Lab-scale experiments	77
3.3.2 Pilot-scale experiments.....	81
3.3.3. Energy balance and cost implications.....	87
3.4 Conclusions	88
3.5 References	90
Chapter 4. <i>Vici</i> : Effects of mild thermal pre-treatment combined with H ₂ O ₂ on waste activated sludge digestibility.....	94
Abstract.....	94
4.1 Introduction	95
4.2 Methods.....	95
4.2.1 Sludge origin and characteristics	95
4.2.2 WAS pre-treatment.....	96
4.2.3 Analytical.....	96
4.2.3.1. <i>COD, pH, solids, VFA, ORP and pH.</i>	96
4.2.3.2. <i>Rheometry.</i>	96
4.2.3.3. <i>Particle size distribution (PSD).</i>	97
4.2.3.4. <i>Catalase activity test.</i>	97
4.3 Results and discussion	99
4.3.1 Physicochemical parameters	99
4.3.2 EPS.....	100
4.3.3 Rheology	101
4.3.4 Methane production rate and extent	103
4.3.5 Possible reasons explaining the viscosity drop.....	107
4.3.6 Implication	108
4.4 Conclusions	109
4.5 References	110
Chapter 5. <i>Vadere</i> : ‘Bricklaying’ activated sludge and the effect of sludge composition in pre-treatment performance.	114
Abstract.....	114
5.1 Introduction	115

5.2 Materials and methods.....	115
5.2.1 Wastewater and liquors sampling	116
5.2.2 Analytics	116
5.2.3 Sludge pre-treatment.....	118
5.2.4 Synthetic wastewaters	118
5.2.5 SBR operation.....	119
5.2.6 Experimental phases	120
5.3 Results and discussion	121
5.3.1 Characteristics of domestic wastewater.....	121
5.3.2 Comparison between domestic and synthetic wastewater	121
5.3.3 Impact of growth media on methane production of pre-treated lab-grown sludge.....	124
5.3.4 Overall discussion	127
5.4 Conclusion.....	128
Appendix 5-1: Biological nutrient removal.	128
5.5 References	130
Chapter 6. Overall discussion, conclusions and outlook.....	133
6.1 Effects of several pre-treatments on WAS and their possible mechanisms.....	133
6.2 Effects of low-temperature thermal pre-treatment combined with the addition of H ₂ O ₂ on the bioconversion of WAS to methane.	134
6.3 Possible mechanisms underlying the effects of low-temperature thermal pre-treatment combined with the addition of H ₂ O ₂ on the increased bioconversion of WAS to methane.	135
6.3.1 Lab-scale implication.....	137
6.4 Influence of the composition of activated sludge on the effectiveness of pre-treatment.	138
6.5 Concluding remarks	138
6.6 References	140
Acknowledgements.....	141
List of publications	142
Biography	143
Supplementary Information	144

Abbreviations:

AD, anaerobic digestion
AMPTS, automatic Methane Potential Test System
ANOVA, analysis of variance
AOP, advanced oxidation process
BCB, bivalent cation bridging
BMP, biochemical methane potential (used also as SMP and CMP)
BOD, biochemical oxygen demand
BSA, bovine serum albumin
CAS, conventional activated sludge
CER, cation exchange resin
CFD, computational fluid dynamics
CHP, combined heat power
CMP, cumulative methane production (used also as BMP and SMP)
COD, chemical oxygen demand
CST, capillary suction time
DNA, deoxyribonucleic acid
DO, dissolved oxygen
EBPR, enhanced biological phosphorus removal
EDTA, Ethylenediamine tetraacetic acid
EPS, extracellular polymeric substances
F/M, food-to-microorganisms ratio
GAO, glycogen accumulating organisms
HP, Harnaschpolder (WWTP)
HRT, hydraulic retention time
ICP-OES, inductively coupled plasma optical emission spectrometry
KV, Kralingseveer (WWTP)
LB-EPS, loosely bound extracellular polymeric substances
LCA, life cycle assessment
M/D, mono-to-divalent cation ratio
MLSS, mixed liquor suspended solids
MW, microwave
n/a, not available
n/d, not determined
n/f, not found
NG, Nieuwgraaf (WWTP)
OLR, organic loading rate
ORP, oxidation reduction potential
PAO, phosphate accumulating organisms
PS, primary sludge
PSD, particle size distribution
PTFE, polytetrafluoroethylene
RPM, revolutions per minute
RT, retention time
SBR, sequencing batch reactor

sCOD, soluble chemical oxygen demand
S-EPS, soluble extracellular polymeric substances
SMP, specific methane production rate (used also as BMP and CMP)
SRT, solids retention time
SS, secondary sludge
STP, sewage treatment plant (same as WWTP)
SVI, sludge volumetric index
SWW, synthetic wastewater
TA, tannic acid
TB-EPS, tightly bound extracellular polymeric substances
TN, total nitrogen
TOC, total organic carbon
TP, total phosphorus
TPAD, thermal phased anaerobic digestion
TS, total solids
TSS, total suspended solids
US, ultrasound
USD, United States dollars
VFA, volatile fatty acids
VS, volatile solids
VSS, volatile suspended solids
WAS, waste activated sludge
WWTP, wastewater treatment plant (same as STP)

Symbols

CBOD₅, carbonaceous BOD at day 5th, mg/L
E_s, specific energy, kJ/gTS
k_{CH₄}, methane production rate, 1/d
k_{CH₄-rapid}, rapid methane production rate, 1/d
k_{CH₄-slow}, slow methane production rate, 1/d
k_{hyd}, hydrolysis rate, 1/d
β, biodegradability, %
β₀, initial biodegradability, %

To my parents, for giving me the freedom to follow my dreams.

Summary

The overall objective of the present study was to investigate the effects of thermal pre-treatment of waste activated sludge (WAS) at 70 °C with addition of H₂O₂ to enhance sludge hydrolysis and subsequent methane production during WAS anaerobic digestion. The research was divided into four parts: Firstly, a bibliographical part, in which literature research revealed that WAS can be considered a mixture of proteins, humic substances, cells (and others). Subsequently, the effects of several pre-treatment techniques on these constituents and on biochemical and physicochemical properties of WAS, such as methane production and dewatering, were analyzed. This part reviews the response of WAS subjected to pre-treatments of different nature (e.g., thermal, acid-base, oxidative) at different energy intensities. It also compiles the role of pre-treatment techniques on sterilization, dewatering and methane production. Ultimately, it was made clear that the mechanisms of most of the pre-treatments still remain unknown, hindering a fair comparison of their effects.

In the second part, the effects of low-temperature pre-treatment with the addition of H₂O₂ on WAS were analyzed in both lab- and pilot-scale scenarios to detect and quantify its effects. During lab-scale experiments, it was found that the application of low-temperature thermal pre-treatment combined with H₂O₂ at 70 °C; 30 minutes and 15 mgH₂O₂/g TS increased the methane production rate, which consisted of 2 differently recognizable parts. The high rate, $k_{CH_4\text{rapid}}$, increased from 0.44 ± 0.01 to 0.47 ± 0.01 d⁻¹ and the low rate, $k_{CH_4\text{slow}}$, from 0.09 ± 0.00 to 0.11 ± 0.01 d⁻¹. There were inconclusive results regarding an increase in specific methane production. The lab-scale observations were reproduced during a pilot-scale experiment, although due to methodological restrictions, pre-treatment was applied together with two-staged compartmentalized digestion. It was observed that due to the adoption of pre-treatment and compartmentalized digestion, organic loading rates could be increased from 1.4 to 4.2 kg volatile solids VS/(m³d), which resulted in a solids retention time (SRT) decrease from 23 to 15 days without apparent process impairment. It was considered that most of the observed effects were caused by the pre-treatment, while the influence of compartmentalized digestion remained marginal in this study.

In the third part, further study at lab-scale was conducted to determine the individual contributions of the separate components of pre-treatments, i.e., thermal and oxidative. For instance, thermal pre-treatment solubilized most of the EPS; deactivated catalase and accelerated the reaction rate of H₂O₂, while H₂O₂ decreased the apparent viscosity of WAS by 12-30%, resulting in a synergistic effect on the WAS digestibility. As suggested by other rheological parameters, the addition of H₂O₂ improved the flowability of WAS at 70 °C. The cause of the decrease in viscosity was not determined. However, the presence of hydroxyl radicals via the Fenton's reagent; the decrease in particle size of WAS, and the combination of H₂O₂ with conditioning agents were discarded. On the other hand, results suggested that the reason behind the decrease in viscosity was the molecular modification of the carbohydrates in WAS as a result of their reaction with H₂O₂.

The above-described experiments were restricted to the grab samples taken at 3 wastewater treatment plants (WWTPs). However, WAS is a matrix of variable composition, depending on location and season. Therefore, in the fourth and last part, the applicability of the pre-treatment methods to WAS with a different composition was tested, using lab-grown sludge. Based on the results, it was inferred that the concentration of metals embedded in lab-grown sludge was relevant for the effectiveness of pre-treatment in terms of methane production, both rate and extent.

The evidence obtained in this study suggests that the lower viscosity of the pre-treated WAS was reflected in the viscosity of the digestate, which allowed a better mass-transfer during non-ideal mixing and therefore a higher methane production rate. Since full-scale digesters are very often poorly-mixed, the applied pre-treatment conditions might be a possible strategy to improve mixing and increasing the BMP without increasing the mixing energy.

Chapter 1. Introduction and thesis setup

This thesis presents the results of a study about the possible mechanism and effects of pre-treatment of waste activated sludge at 70 °C with the combined addition of H₂O₂. To properly introduce the topic, a few concepts important for the performed research are defined:

Activated sludge, is a biological mixture of microbial mass with biopolymers, which is the core of the conventional activated sludge (CAS) process. At present, CAS is likely the most common wastewater treatment process around the world. Activated sludge is mostly composed of the secretions of the microorganisms that mediate the biochemical oxidation of the wastewater constituents. During this process, the organic components in wastewater, e.g., fecal matter, urine, food residues, among others, are oxidized and mineralized into less reactive molecules, such as CO₂, water and others. As a consequence, the treated wastewater decreases its noxious character. However, during this process the microorganisms also reproduce and the resulting newly-growth sludge must be removed to maintain a stable treatment process, resulting in *waste activated sludge* (WAS).

It has been calculated that each person produces 14-55 kg of WAS per year on a dry basis (Wu et al., 2020). Moreover, the disposal of WAS may account for 50-60% of the operational cost of a wastewater treatment plant (WWTP) (Khanal et al., 2007; Kroiss, 2004). From a more detailed point of view, WAS is not only composed by microbes and their secretions, but also of metals, fibers and inert matter (Figure 1.1). However, WAS does not possess a fixed and well-defined composition, since it is susceptible to wastewater composition, season of the year and operational conditions of the wastewater treatment plant, among other factors.

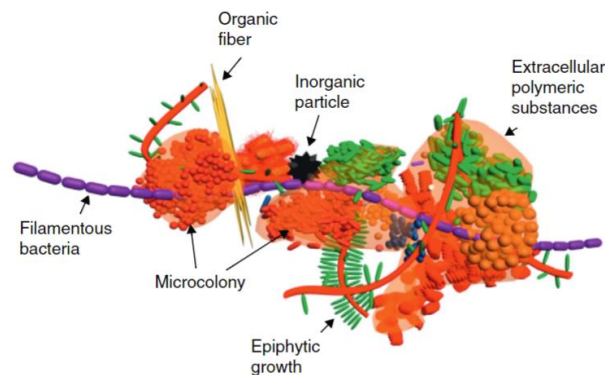

Figure 1.1 Model of an activated sludge floc. Extracted from Nielsen et al. (2012).

Anaerobic digestion (AD), is commonly used as a method to stabilize WAS, and to decrease its biochemical hazard potential. Anaerobic digestion is also a biological process; however, in contrast to the CAS which requires oxygen to oxidize the organic compounds, AD proceeds without it, and thus different consortia of microorganisms are involved. The degradation of WAS via AD results in the production of methane, CO₂ and trace gases. However, the efficiency of the conversion of WAS to methane is around 30-35% of the stoichiometric amount, mostly due to the recalcitrance of WAS. As a consequence, WAS is normally digested for 3-4 weeks due to its slow biochemical methane production rate, thus requiring big digesters.

To increase the efficiency of anaerobic digestion during WAS bioconversion, different WAS *pre-treatment techniques* have been proposed. Pre-treatments are unit operations before anaerobic digestion, consisting of the application of several different mechanisms such as ultrasounds, microwaves, alkalization, thermal, amongst others. Most of the pre-treatments have been applied only under lab-scale conditions and have resulted in benefits such as improved hygienization; better dewaterability, and increased methane production. On the other hand, there are also drawbacks such as substantial capital and operational expenditures, process complexity and the possible formation of refractory products. There are several reports on the application of some pre-treatment techniques in full-scale scenarios, although the mechanisms of the majority of them remain unknown.

Results suggest that specific pre-treatments are affecting specific WAS components. Therefore, commonly, pre-treatment techniques are combined to potentiate their effects. In this regard, in the present study, we focused on a combination of two pre-treatment techniques: thermal (70 °C) and chemical (H₂O₂) to increase the amount of produced methane and its production rate (k_{CH_4}). The selection of the combination of pre-treatments was based on its apparent simplicity, low-resource use, and the often-contradictory reports in the literature about the efficacy of such combination.

1.1 Research setup and thesis outline

1.1.1 Objectives

The overall objective of the present study was to quantify the benefits and limitations of thermal pre-treatment of WAS at 70 °C with addition of H₂O₂ on the increase in methane production during anaerobic WAS digestion and to propose a mechanistic interpretation of the results. The particular objectives are:

- a) To review the possible mode of action, effects on specific WAS components and limitations of different WAS pre-treatments.
- b) To quantify possible effects and their extent on the anaerobic digestion of low-temperature thermal pre-treatment combined with the addition of H₂O₂ on WAS in lab- and pilot-scale scenarios.
- c) To propose a possible mechanism of low-temperature thermal pre-treatment with the addition of H₂O₂ on the properties of WAS and in the subsequent AD of pre-treated WAS.
- d) To cultivate lab-grown sludge with a similar BMP and k_{CH_4} compared with full-scale WAS and to modify such characteristics via growth-media.

1.1.2 Research questions

The following research questions were formulated:

- a) What is the current state-of-the-art knowledge regarding the effects and possible mechanisms of WAS pre-treatments?
- b) What is the effect of low-temperature thermal pre-treatment of WAS combined with H₂O₂ addition on methane production in both lab- and pilot-scale scenarios?
- c) Which WAS components or characteristics are impacted by low-temperature pre-treatment with the addition of H₂O₂ in combined and separated form?
- d) Does WAS composition influence the effectiveness of pre-treatment in terms of methane production?

1.1.3 Outline

To achieve the objectives and to answer the research questions, a bibliographic and experimental study was performed. The results are divided into four chapters, as presented below:

In **Chapter 2**, '*Veni*': *to come*, available literature on the effect of several pre-treatment techniques is extensively reviewed, together with the reported composition of several WAS samples in terms of proteins, humic substances, carbohydrates and cells. In addition, the operational parameters of each of the studied pre-treatment techniques and their effects on the specific constituents, as well as on biochemical and physicochemical properties of WAS, such as biogas production and dewaterability are discussed. The chapter concludes with a discussion about the benefits and drawbacks of the application of each pre-treatment technique, and about the state-of-the-art regarding how research of pre-treatments is commonly conducted.

Chapter 3, '*Vidi*': *to see*, focuses on the application of low-temperature thermal pre-treatment with the addition of H₂O₂ to increase methane production of WAS during anaerobic digestion. Firstly, a full-factorial design of experiments using the operational parameters temperature, application time and H₂O₂ dose was performed in lab-scale experiments to identify the best pre-treatment settings. Secondly, using such conditions, a pilot-scale experiment was set up to evaluate the effectiveness of the combined pre-treatment in a real-world scenario. Finally, a discussion of the observed results and their possible causes is presented.

In **Chapter 4**, '*Vici*': *to conquer*, consists of a more detailed study of the effects observed at the pre-treatment conditions used in the previous chapter. The modification of the particle size distribution, the presence of Fenton's reagent, and the presence of cationic polymers were studied as possible reasons behind the observations of Chapter 3. Two possible mechanisms explaining the increased methane production of WAS were discussed: a physical one, induced by the modification of WAS rheology; and a biochemical one, originated by a higher accessibility of the WAS components. Finally, the individual contribution of each pre-treatment is discussed.

While in Chapter 4 the composition of sludge was 'fixed' by utilizing grab samples of sludge and the pre-treatment conditions were modified, in **Chapter 5**, '*Vadere*': *to advance*, the opposite approach was adopted: pre-treatment conditions were fixed while the composition of lab-grown sludge was modified by the variation of the growth-media. Thus, a change in methane production of lab-grown sludge was induced to assess the effectiveness of pre-treatment on sludge with a different composition. The chapter concludes with a discussion of the observations and their possible reasons.

Finally, in **Chapter 6** the research findings from the previous chapters are framed together and discussed. Possible implications and an overview for possible future researches are also presented.

1.2 References

- Ferguson, E.S., 1992. *Engineering and the Mind's Eye*. MIT press.
- Jain, R., Triandis, H., Weick, C., 2010. Managing research, development and innovation: Managing the unmanageable.
- Khanal, S.K., Grewell, D., Sung, S., van Leeuwen, J. (Hans), 2007. Ultrasound Applications in Wastewater Sludge Pretreatment: A Review. *Crit. Rev. Environ. Sci. Technol.* 37, 277–313.
<https://doi.org/10.1080/10643380600860249>
- Kroiss, H., 2004. What is the potential for utilizing the resources in sludge? *Water Sci. Technol.* 49, 1–10.
- Nielsen, P.H., Saunders, A.M., Hansen, A.A., Larsen, P., Nielsen, J.L., 2012. Microbial communities involved in enhanced biological phosphorus removal from wastewater-a model system in environmental biotechnology. *Curr. Opin. Biotechnol.* 23, 452–459.
<https://doi.org/10.1016/j.copbio.2011.11.027>

Chapter 2. *Veni*: Effects of pre-treatments on WAS: a review of causes, possibilities and limitations.

This chapter is originally published as:

Gonzalez, A., Hendriks, A.T.W.M., van Lier, J.B., de Kreuk, M., 2018. Pre-treatments to enhance the biodegradability of waste activated sludge: Elucidating the rate limiting step. *Biotechnol. Adv.* 36, 1434–1469. <https://doi.org/10.1016/j.biotechadv.2018.06.001>

Abstract

Pre-treatments for waste activated sludge (WAS) are, in most cases, an attempt to increase the biodegradation and/or improve hydrolysis rate of WAS after anaerobic digestion. This review presents an extensive analysis of WAS pre-treatments effectiveness focusing on increasing the biodegradability. In the first part of the review, WAS is considered as a cluster of organic components: proteins, carbohydrates, humic substances and cells. Based on the breakdown into components, the effects of different pre-treatments on each component (and in combination) is described. Also, possible reasons for the contradictory results frequently found among different studies dealing with the same pre-treatment are included. In the second part, the review describes the effects on volatile solids removal by digestion after pre-treatment and on the dewaterability of the final digestate. The energy balance and potential limiting factors for each pre-treatment are also taken into account. From the published works it is concluded that some pre-treatment techniques, such as thermal hydrolysis, thermal phased anaerobic digestion and low-temperature pre-treatment are effective ways to increase energy production and to improve other sludge properties, such as dewatering. However, these techniques are very energy intensive and require a large capital outlay, so research on milder pre-treatment techniques is valuable.

Keywords: anaerobic digestion; methane production; pre-treatment; review; sewage sludge; waste-activated sludge.

2.1 Introduction

Waste activated sludge (WAS) and primary sludge are the main by-products from conventional activated sludge treatment and their disposal is relevant because it may cause around 50% of the total operational costs of a sewage treatment plant (Kroiss, 2004; Pilli et al., 2011). Methods like anaerobic digestion (AD) are used to reduce the costs associated with sludge disposal. AD is a widely used sludge treatment method. Its advantages include low energy input, methane production and reduction of sludge quantity. However, its application is often limited by low biodegradability and high retention times, because the complexity of WAS limits the efficacy of the biological process (Ruffino et al., 2016). For instance, in WAS originating from biological nutrient removal wastewater treatment plants (WWTP), only about 30-35% of the organic solids are anaerobically biodegraded in a mesophilic reactor at 20-25 days solids retention time (SRT) (Hiraoka et al., 1985; Ruffino et al., 2015; Valo et al., 2004). To overcome these drawbacks, a substantial amount of research has been done with the aim of increasing both the rate and extent of WAS bioconversion. As a result, several conditioning techniques or *pre-treatments* of sludge prior to AD have been tested in bench, pilot, and full scale. These methods have been applied mostly to WAS, as primary sludge is easier to biodegrade (Kuglarz et al., 2013; Müller, 2001).

The effects of each pre-treatment method depend on its inherent mechanisms. For instance, Salsabil et al. (2010) postulated that the degree of sludge solubilization depends upon the kind of treatment (mechanical, oxidative, thermal) rather than upon the specific energy input. Similarly, Cella et al. (2015) concluded that the innate characteristics of the pre-treatment method are likely more important than energy input. The objectives of this review paper are a) to identify the effects of different pre-treatment methods on the proteins, carbohydrates, humic substances and cells contained in the WAS; b) to assess and compare the biological degradability (hydrolysis rate, biogas production and removal of organic matter), dewaterability of the digestate and energy consumption between the pre-treatments. The paper considers only the effects of individual pre-treatments (combinations of pre-treatments are excluded). It starts with an introduction of how anaerobic biodegradability and biodegradation should be defined and gives an overview of the composition of WAS. Then, several pre-treatment methods are discussed based on their underlying mechanisms; the effects on the main WAS components and their strengths and limiting factors. Finally, a discussion and conclusion with an overview of present knowledge gaps is presented.

2.1.1 Anaerobic biodegradability and biodegradation

Chemical oxygen demand (COD) solubilization is commonly used as a parameter to evaluate the effectiveness of pre-treatment (Neumann et al., 2016). Indeed, applying certain pre-treatment conditions, some studies have documented that there is a relationship between COD solubilization and biodegradation (Bougrier et al., 2008; Uma Rani et al., 2012). However, in other cases, higher COD solubilization did not result in a higher biogas production, but sometimes in the same or even lower biogas production (Dhar et al., 2012; Haug et al., 1978; D.-H. Kim et al., 2013; J. Kim et al., 2013; Nazari et al., 2016; Sapkaite et al., 2017). Since COD solubilization is apparently not an accurate parameter to predict the effectiveness of subsequent biogas production (Sapkaite et al., 2017), until now, batch or (semi)continuous, anaerobic digestion methods are the only useful and accurate tools to assess the effect of pre-treatments on the anaerobic biodegradability of WAS. In this sense, biodegradability is a characteristic of sludge and in anaerobic digestion processes is composed of hydrolysis rate and

biodegradation extent. Biodegradation is determined via biomethane potential (BMP) test, which in turn is determined by methane production which depends, amongst other variables, on temperature, sludge retention time, inoculum-substrate ratio, BMP and hydrolysis rate (Angelidaki et al., 2009; Chen and Hashimoto, 1980; C. Holliger et al., 2016; Wang et al., 2013). Many papers, however, use different digestion times, which make comparison of data difficult; others report biogas or methane production without disclosing COD or volatile solids (VS) of WAS, making the calculation of biodegradability clumsy. As a consequence, in this paper, we mostly use biodegradation to assess the effectiveness of pre-treatments.

A standard method for BMP determination is published in Holliger et al. (2016): research would benefit from adapting to this methodology in order to be able to better compare data. In addition, by only giving information regarding biodegradation, it is not clear if a pre-treatment only has an effect on the BMP, or also on the hydrolysis rate constant, or on both. To be able to accurately perform inter-study comparison, BMP and hydrolysis rate should be both reported (instead of only showing the multi-interpretable change in biogas production).

As mentioned, because many papers do not mention BMP nor the hydrolysis rate, the biodegradation (B_0), shown in Eq. 2.1, will be used to assess the effectiveness of pre-treatments in this review. This value is presented as “absolute biodegradation” and it is calculated based on the given data from the different studies reviewed. B_0 is the actual methane production of a sludge sample divided by the maximum theoretical conversion of COD to methane (0.35 L CH_4 /gCOD, at standard temperature and pressure)(D.-H. Kim et al., 2013; Mottet et al., 2009). This parameter, however, does not consider what is needed for bacterial cell growth, their maintenance, nor the COD reduction due to the presence of other electron acceptors. The contribution of growth and maintenance to COD removal has been reported to be 5-10% of organic material degraded (Angelidaki and Sanders, 2004). This means that an underestimation of the biodegraded part occurs because not all biodegraded COD is transformed into methane. Whenever possible, in this manuscript the apparent first order hydrolysis rate (k_{hyd}) and volatile solids (VS) reduction are also used along with B_0 to assess the effects of pre-treatments on anaerobic biodegradability of WAS.

$$B_0 (\%) = 100 \times \frac{\text{Measured Methane production} \left(Nml \frac{CH_4}{gCOD_{added}} \right)}{350 ml \frac{CH_4}{gCOD_{added}}} \quad (\text{Eq. 2.1})$$

2.1.2 Composition of waste activated sludge

To comprehend the effects of the different pre-treatments on the anaerobic biodegradability of WAS, its composition should be known. Table 2.1 shows the results of a collection of studies that focused on the composition of WAS in terms of viable and nonviable cells, proteins, carbohydrates, humic acids and DNA. Despite a myriad of studies that provide WAS characterization in terms of COD, proteins and carbohydrates, only a few show the concentration of cells, active biomass and humic substances. From Table 2.1, a remarkable variation of the WAS composition is observed. For instance, in terms of %VS, it is composed of 10-24% bacterial biomass; 7-19% carbohydrates; 25-62.4% proteins; 7.7-28.6% humic substances; and <3.5% DNA. It is important to note that the method used to determine each component influences the results (Bourven et al., 2012; Comte et al., 2006; Wilén et al., 2003). Nonetheless, from

Table 2.1, it is concluded that WAS is composed mostly of proteins and humic substances with some bacterial biomass and carbohydrates (listed in decreasing order of %VS).

Proteins, DNA and carbohydrates are anaerobically biodegradable compounds. However, when they are combined into an organized structure like WAS, their biodegradability apparently decreases (Stuckey and McCarty, 1984). Cells are difficult to break down under anaerobic digestion, showing their recalcitrant nature (Foladori et al., 2015; Wett et al., 2010). Similarly, the presence of humic substances is challenging for anaerobic digestion as they affect enzymatic activity by immobilizing enzymes, which, consequently lowers biodegradability (Azman et al., 2015a, 2015b; Fernandes et al., 2015; Frølund et al., 1995; Wetzel, 1991). In addition, humic substances themselves are difficult or impossible to degrade anaerobically (Nielsen et al., 1997; Pinnekamp, 1989; Tian et al., 2015a; Zahmatkesh et al., 2016). Since humic substances account for 10-20% of the COD of WAS, the maximum attainable anaerobic biodegradation of WAS cannot exceed 80-90%. Therefore, an assessment of a pre-treatment method must consider that obtaining a 100% degradation is difficult unless oxidative methods are incorporated.

Table 2.1 Literature review of WAS composition. Values as %VS (unless otherwise stated).

Bacterial Biomass	Protein	Carbohydrate	Humic substances	DNA	Uronic acids	Wastewater source	Type of treatment	Determination method for bacterial biomass; exopolymeric substances (EPS) and humic substances	Reference
15%*	25*	7*	16*	<1*		Municipal	n/a This sample was a biofilm	Polysaccharide: anthrone method (glucose as standard) Uronic acids: m-hydroxydiphenil sulfuric acid method (D-glucuronic as standard) DNA: 4',6'-diamidino-2-phenylindole Protein: Lowry method (corrected for humic substances) Humic substances: modified Lowry methods Cell number: epifluorescence microscopy	(Jahn and Nielsen, 1998)
11-24	76-89				n/d	n/a	n/a	Bacterial biomass: acridine orange staining and confocal laser scanning microscopy Other components: subtraction of cell volume from total volume	(Zhang and Fang, 2001)
n/d	"Most abundant fraction"	"Similar as humic substances"	15-20	n/d	n/d	n/a	n/a	cation exchange resin (CER) (Dowex®)	(Frølund et al., 1995)
10-15	46-52	17	18-23	n/d	n/d	n/a	Biological and chemical nutrient removal	CER (Dowex®); 4',6'-diamidino-2-phenylindole; staining and acridine orange	(Frølund et al., 1996)
9-14*	n/d	n/d	n/d	n/d	n/d	n/a	Biological nutrient removal	Acridine orange staining	(Münch and Pollard, 1997)
n/d	n/d	n/d	17 (of TOC)	n/d	n/d	Domestic	n/a	Sodium hydroxide and sulphuric acid	(Riffaldi, 1982)
n/d	46.1	13.5	7.7	n/d	n/d	10 sources	n/a	CER (Dowex®)	(Mikkelsen and Keiding, 2002)
n/d	50	16-19	16-19	n/d	1	Domestic	Biological and chemical nutrient removal	CER (Dowex®)	(Nielsen et al., 1996)
n/d	62.4	10.8	26.4	0.4	n/d	n/a	n/a	CER (Dowex®)	(Schmid et al., 2003)
n/d	59	15.9	24.9	0.2	n/d				
n/d	53.4	17.8	28.6	0.2	n/d				
14.5*	n/d	n/d	n/d	n/d	n/d	Municipal	-	SYBR® green staining	(Foladori et al., 2010)
n/d	27.1	10.4	24.4	2	n/d	Domestic and industrial	Nutrient removal	CER (Dowex®)	(Wilén et al., 2003)

n/d	48.4	8.8	26.2	1.6	n/d	Domestic	Secondary		
n/d	32.2	11.3	16.1	1.9	n/d	Domestic	Nutrient removal		
n/d	37.8	11.6	16.4	3.5		Domestic	Nutrient removal		
n/d	31.5	8.6	15.6	2.1		Domestic	Nutrient removal		
n/d	27.1 (as VSS)	10.4 (as VSS)	24.4 (as VSS)	n/d		50% domestic, 50% industrial	C, N and P removal	CER (Dowex®)	(Jin et al., 2004)
n/d	48.4 (as VSS)	8.8 (as VSS)	26.2 (as VSS)	n/d		Mainly domestic	Carbon removal		
n/d	31.8 (as VSS)	11.1 (as VSS)	15.9 (as VSS)	n/d		Mainly domestic	Carbon and nitrogen removal		
n/d	38.2 (as VSS)	11.8 (as VSS)	16.6 (as VSS)	n/d		Mainly domestic	C, N and P removal		
n/d	31.5 (as VSS)	8.6 (as VSS)	15.6 (as VSS)	n/d		Mainly domestic	C, N and P removal		
n/d	40.0 (as VSS)	7.6 (as VSS)	8.7 (as VSS)	n/d		Oil refinery	Carbon removal		
n/d	32.4 (as VSS)	9.3 (as VSS)	31.0 (as VSS)	n/d		Leachate	Carbon and nitrogen removal		

^a Carbohydrates and humic acids were considered together

n/a: not available

n/d: not determined

*Based on COD

2.2 Pre-treatment methods

In the following sections, several sludge pre-treatment methods will be discussed. First a process description of the pre-treatment will be given, whereupon the effect of the pre-treatment on the different individual WAS components will be discussed.

2.2.1 Thermal pre-treatment <100 °C

Process description and mode of action

Mild-thermal or low-temperature thermal pre-treatment consists of the application of a temperature range from 55-100°C from minutes to several hours during a certain time period. It is differentiated from thermal phased anaerobic digestion (TPAD) in which longer times (in the range of 1-3 days are applied). TPAD is analyzed in the following section. Low-quality heat (e.g., waste heat) can be applied through heat exchangers. The operational parameters are temperature and application time. Its main effect is the disintegration of cell membranes and a concomitant solubilization of organic compounds (Nazari et al., 2016).

Effects on WAS

Floc and cell disruption

Reduction in particle size (i.e. deflocculation) has been observed in the range of 50-95°C (Laurent et al., 2009a; Prorot et al., 2011), which, in turn, reduces sludge dewaterability (Pérez-Elvira et al., 2010), but could increase hydrolysis rate because of the increased surface area (Vavilin et al., 2008). Regarding cell disruption, according to Forster et al. (2002) more than 95% of the bacterial biomass in WAS consists of Gram-negative bacteria. Gram-negative bacteria are more sensitive to heat than Gram-positive (Salton and Horne, 1951). Prorot et al. (2011) observed that lysis of a portion of the cells already occurred at 50°C and treatment times of 20 minutes, and also that cell lysis increased proportionally to temperature up to 95°C. Salton and Horne (1951) also visually determined that cell disruption occurred from 70-100°C and 5 minute application times, and that different bacterial strains were disrupted at different temperatures. Thus, during low-temperature thermal pre-treatment, the cell wall of at least a fraction of the bacterial biomass is ruptured and the internals of the bacteria should become available for digestion. As a consequence, a (relatively small) increase in WAS biodegradability is expected.

Carbohydrates, proteins and humic substances

The effect of low-temperature thermal pre-treatment on carbohydrates is an increase in solubilization, as observed by Dong et al. (2015) at 60°C, and by Appels et al. (2010) at 80°C. The solubilization of carbohydrates could increase the biodegradation rate during anaerobic digestion, but probably not the biodegradability of WAS, because carbohydrates are usually biodegraded to a large extent by anaerobic microorganisms. An exception are extracellular polymeric substances (EPS) of aerobic granular sludge (Guo et al., unpublished results), which are also present in WAS.

Protein denaturation typically occurs above temperatures of 75°C (De Graaf, 2000). Denaturation makes proteins more prone to biodegradation (Anson, 1938), so an increase in biodegradation rate would be expected at pre-treatment temperatures above 75°C. The solubilization of proteins is higher than that of carbohydrates (Appels et al., 2010; Dong et al., 2015), which results in the availability of more easily degradable organic matter. Nevertheless, Appels et al. (2010) and Dong et al. (2015) observed that the

solubilization of both components did not exceed 20% of their total fraction. This suggests that a significant amount of carbohydrates and proteins remain bound in the WAS matrix, forming a heat stable fraction.

Humic acids only become more flexible above their glass transition temperature at about 70-80°C (Kolokassidou et al., 2007). However, the fraction of solubilized humic substances remained constant from 75 to 120°C (Laurent et al., 2009b) and from 25 to 80°C (Zhen et al., 2012), suggesting that humic acids are not affected during low-temperature thermal pre-treatment. Nonetheless, the presence of humic-like substances could affect WAS biodegradability. For instance, Wang et al. (2015) stated that protein-like components could be trapped by humic-like components thus forming molecular assemblies and making proteins less susceptible to microbial degradation (Azman et al., 2015b; Tan et al., 2008; Wang et al., 2015). A humic acid-protein assembly would mean that proteins are protected from denaturation and degradation thus limiting WAS biodegradability and explaining why proteins are not completely degraded, even at applied pre-treatment temperatures of around 90°C, as observed by Appels et al. (2010).

Hydrolysis rate and biodegradation

Liao et al. (2016) and Prorot et al. (2011) have reported that low-temperature thermal pre-treatment increases hydrolysis rates at temperatures ranging from 60 to 70°C. Sanders et al. (2000) and Vavilin et al. (2008) stated that when dealing with particulate organic material (such as WAS), the decrease in particle size results in higher hydrolysis rates during anaerobic digestion. Complementarily, the solubilization of organic material could also speed up the hydrolysis rate.

Regarding sludge biodegradation, despite most studies claim an increase, Prorot et al. (2011) found no significant impact in methane yield, even though organic matter solubilization and cell lysis occurred. The operational conditions were a temperature of 95°C and an application time of 20 minutes. For the studies that report an increase in biodegradation, the varying results are shown in Table 2.2. An explanation for the different outcomes after pre-treatment may be the relation between temperature and treatment time, as has been observed by Hiraoka et al. (1985). This hypothetical relation may be observed (for instance) in the study of Appels et al. (2010) (Table 2.2, entries g and h), which shows similar methane production at 80°C coupled with an application time of 60 minutes and at 90°C with an application time of 15 minutes. Probably because of the temperature-time relation, an analysis of the biodegradation of WAS must consider the effect of both parameters.

Pre-treatments with a temperature range of 50-95°C and an application time of 60 minutes or less (entries from a to j) generally result in increased methane production, even though the results are very different among the studies (Table 2.2). A word of caution must be said about the paper of Appels et al. (2010) (entries e, g and h) in which the control sample had a very low biodegradation, probably because of a low inoculum-substrate ratio of 0.10 during the digestion and a very limited solubilization for the sample that was pre-treated at 70°C. The changes in the different elements of WAS, as described above, are due to the following factors: disruption of cell membranes; maximized solubilization of carbohydrate and protein; and protein denaturation at temperatures above 75°C. These factors could influence the observed increase in biodegradation at 50-95°C and application times of less than 60 minutes.

Increased application times (6-15 hours) at a moderate temperature increase (60-70°C), seems to result not only in an increased biodegradation, but also in steadier results (Table 2.2, entries k to o). The

observed increase in methane production cannot be explained solely by the COD solubilization, as its maximum release is reached at times lower than one hour. It is hypothesized that the pre-treatment may have had an effect on the particulate fraction when longer application times are applied, thus increasing its biodegradation. A further increase in application times (up to 1-7 days) at a temperature between 55 and 70°C, seems to result in a similar or even lower biodegradation compared to the untreated samples (Table 2.2, entries p to s). A possible explanation is the occurrence of the amino-carbonyl (Maillard) reaction (Appels et al., 2010; Liao et al., 2016), which occurs at a low rate at temperatures of 60°C (Chiu et al., 2009). The products of the Maillard reaction are refractory; and decrease digestibility; and inhibit proteolytic and glycolytic enzymes activity (Friedman, 1996); and are generally detrimental to cells and organisms (Szwergold, 2013).

Finally, as observed in entries t to w, a simultaneous increase in temperature (between 80-90°C) and application time (3 to 10 hours) results in conflictive and spread results. The results in this range are comparable to the ones obtained at 60-75°C and application times between 3 and 15 hours.

Table 2.2 Effects on the biodegradation of WAS after thermal pre-treatment <100°C.

Entry	Temperature, °C	Application time	Change in biodegradation (vs. control)†	Change in CH ₄ production (vs. control)	Change in biogas production (vs. control)	Reference
Temperature 50-95°C Application times ≤ 60 minutes						
a	50	30 minutes		↑ 13.8%		(Dhar et al., 2012)
b	60	60 minutes			↑ 30%	(Hiraoka et al., 1985)
c	60	60 minutes			↑ 12%	(Ennouri et al., 2016)
d	70	30 minutes		↑ 18.8%		(Dhar et al., 2012)
e	70	60 minutes		↑ 1.6%		(Appels et al., 2010)
f	72	7.5 minutes	↑11% (from 29 to 40)			(Vergine et al., 2014)
g	80	60 minutes		↑ 124%		(Appels et al., 2010)
h	90	15 minutes		↑ 123%		(Appels et al., 2010)
i	90	30 minutes		↑ 13.2%		(Dhar et al., 2012)
j	95	20 minutes	=			(Prorot et al., 2011)
Temperature 60-75°C Application times between 3 and 15 hours						
k	60	6 hours	↑ 8% (from 21 to 29)			(J. Kim et al., 2013)
l	70	3 hours	↑ 7% (from 32 to 39)			(Ruffino et al., 2015)
m	70	9 hours			↑ 50%	(Climent et al., 2007)
n	70	15 hours	↑ 6% (from 32 to 38)			(Ruffino et al., 2015)
o	75	6 hours	↑ 14% (from 21 to 35)			(J. Kim et al., 2013)
Temperature 55-70°C Application times between 1 and 7 days						
p	55	24 hours	↑ 1% (from 38 to 39)			(Wang et al., 2014)
q	70	24 hours	↑ 3% (from 38 to 41)			(Wang et al., 2014)
r	70	1-7 days		↑ 5%		(Gavala et al., 2003)
s	70	3 days			↓ 10%	(Climent et al., 2007)
Temperature 80-90°C Application times between 3 and 10 hours						
t	80	3 hours	↑ 9% (from 28 to 37)			(Ruffino et al. 2015)
u	80	10 hours		↓ from 291 to 281 ml/gVS		(Nielsen et al., 2011)
v	90	3 hours	↑ 9% (from 28 to 37)			(Ruffino et al. 2015)
w	90	6 hours	↑ 5% (from 21 to 26)			(J. Kim et al., 2013)

† An empty cell indicates that there was not sufficient information to calculate biodegradation. In those cases, increase in methane or biogas production is presented.

Limiting factors, advantages and perspectives

Low-temperature thermal pre-treatment is a potential inexpensive way to increase the sludge biodegradability. Because the influence of both time and temperature, a proper selection of both parameters may be fundamental. The mechanism of the temperature-time dependence remains unclear and should be further studied. Nonetheless, steady and more reliable increases in methane production have been found at 60-75°C and application times between 3 and 15 hours. At temperatures of 80-90°C conflictive results have been found, probably due to the increased rate of the Maillard reaction. Finally, the option of using low quality heat has a positive effect on the energy balance of the entire process. An unfortunate side-effect of this technique is the worsening of the dewaterability of the digestate (Table 2.14).

2.2.2 Temperature phased anaerobic digestion (TPAD)

Process description and mode of action

TPAD separates the digestion process into at least two stages, each one providing optimum conditions for hydrolytic/acidogenic and acetogenic/methanogenic microorganisms. The selection mechanisms (and operational parameters) are temperature, application time and pH. Temperature has more relevance to the outcomes of the process compared to application time (Ge et al., 2011a). For the acidogenic phase, temperatures between 45°C and 70°C and retention times of 2-6 days are used, while for the methanogenic phase mesophilic or thermophilic conditions with solids retention time of 14-30 days are used.

Effects on WAS

Floc and cell disruption / carbohydrates, proteins and humic substances

Ghasimi et al. (2016b) observed that thermophilic hydrolysis might be increased due to a high sludge loading leading to accumulation of protein-like substances in the reactor broth, which might be related to hydrolytic enzymes. However, to our best knowledge no studies have been conducted dealing with the fate of cells, proteins, carbohydrates and humic substances in the first stage of TPAD. Nonetheless, the effects are expected to be similar to those described for thermal pre-treatment below 100°C, since the same range of temperatures are used, while only application times are lengthened. As TPAD involves a biological stage coupled with a temperature increase, the mechanism of action and the contribution of both chemical and biological conversions require further research.

Hydrolysis rate and biodegradation

From Table 2.3, it is clear that TPAD increases the WAS biodegradation. J. Yu et al. (2013) observed an increase of 84.8% in methane production in an acidogenic stage at 45°C with a retention time of 4 days, while Ge et al. (2011a) found no increase in methane production at 50°C and 60°C, but an increased hydrolysis rate in the subsequent methanogenic stage. The increase in biodegradability observed in the same study at 70°C with 4 days of retention time, suggests that the effects of Maillard reaction, usually occurring during thermal pre-treatment <100°C, were absent in TPAD. A reason could be that the

increased enzymatic activity in the first stage of TPAD (Ghasimi et al., 2016b) can alleviate the effects of the formation of Maillard products due to the increased presence of hydrolytic enzymes or to the fact that some organisms have enzymatic ways to protect themselves against the Maillard reaction products (Szwergold, 2013). During the acidogenic stage, Ge et al. (2011b) reported the production of methane even at residence times shorter than four days, and at temperatures between 50°C and 60°C.

Table 2.3 Effects on the biodegradation of WAS after TPAD.

Entry	Acidogenic stage			Methanogenic stage			Change in biodegradation (compared to single stage)	Change in CH ₄ production (compared to single stage)	Reference
	Temperature, °C	Retention time, day	pH	Temperature, °C	Retention time, day	pH			
a	45	4	6.05	35	16	-		↑ 85%	(J. Yu et al., 2013)
b	50	2	7	37	14	-	34% †		(Ge et al., 2011a)
c	55	6	7.54	35	24	7.53	↑ 18% (from 39 to 57)		(Wu et al., 2016)
d	55	2	6.8	55	18	8.2	↑ 11% (from 33 to 44)		(Leite et al., 2016)
e	60	2	7	37	14	-	41% †		(Ge et al., 2011a)
f	65	2	7	37	14	-	43% †		(Ge et al., 2011a)
g	65	2	6.3	55	18	7.9	↑ 5% (from 51 to 56)		(Bolzonella et al., 2012)
h	70	2	7	37	14	-	48% †		(Ge et al., 2011a)
i	70	2	-	35	14	-	↑ 15% (from 16 to 31)		(Ge et al., 2011b)

†Absolute biodegradation, no control disclosed

Thermophilic conditions, applying 2-3 days retention time, have been reported to provide better results in terms of increased biodegradation (Bolzonella et al., 2007; Ge et al., 2011a; Riau et al., 2012; Q. Wang et al., 2016). The pH seems to act as a selection mechanism, which impacts biodegradability; with pH values close to neutrality giving increased biodegradability (Ge et al., 2011a) or volatile fatty acids (VFA) yields (Q. Wang et al., 2016), as compared to pH values between 4 and 5. According to the reported studies, the best results during the acidification step occur at temperatures between 65 and 70°C; retention times ranging from 2 to 3 days; and a pH of 6-7.

Limiting factors, advantages and perspectives

Riau et al. (2012) observed that even though the acidogenic effluent has poor dewaterability, a subsequent mesophilic digestion was able to reduce the ‘time-to-filter’ by more than 50% compared to a single-stage anaerobic digestion with the same process duration. This suggests that with this technique the addition of an acidification step may reduce the required amounts of polyelectrolyte for dewatering the digestate. A comparison of the biodegradation changes for low-temperature thermal pre-treatment and TPAD in Table S2-1 shows more prominent increases for TPAD, even though similar temperatures are applied. A possible explanation could be the higher production of protein-like substances at 55°C compared to 35°C conditions (Ghasimi et al., 2016b) caused by the presence of biological activity during the pre-treatment.

2.2.3 Thermal pre-treatment ≥100 °C

Process description and mode of action

High-temperature thermal pre-treatment or thermal hydrolysis relies on the application of temperatures above 100°C and was originally developed to sterilize the sludge and produce class A biosolids. To provide heat, steam is commonly used through heat exchangers or more commonly by direct injection (Pilli et al., 2014) resulting into a high pressure, which is suddenly release. In such cases, not only the effect of temperature is present but also that of the abrupt pressure drop, which increases both solubilization (Donoso-Bravo et al., 2011) and methane production (Sapkaite et al., 2017). The relevant parameters are temperature, application time, pressure, and the presence of a sudden pressure drop. Compared with application time, temperature has a higher influence on solubilization (Li and Noike, 1992; Valo et al., 2004; Xiao and Liu, 2006). Cambi™ and Exelys™ are industrial-scale technologies consisting of one or more pressurized tanks; reaching up to 160°C for 30 minutes and 6 bar for Cambi™; and up to 180°C for 60 minutes and 10 bar for Exelys™. Cambi™ works in batch mode; whilst Exelys™ operates in plug flow mode. ‘Steam explosion’ in the Cambi process is achieved by suddenly reducing the pressure to two bar. Heat is then recovered and returned to the preheating stage. A detailed description of these processes is provided by Pilli et al. (2014).

The mechanism of thermal hydrolysis is best understood by highlighting two observations from Bougrier et al. (2008). Firstly, they observed that from 95 to 170°C, the extent of biogas production from the soluble fraction was higher than that from the particulate fraction. Secondly, the observed increase in biodegradation was caused by the transfer of organic matter from the particulate fraction to the soluble one, but did not lead to an increase in the biodegradation of each fraction (Bougrier et al., 2008), while Pérez-Elvira et al. (2016) found that the biodegradation of the solid fraction remained constant after pre-treatment at 170°C for 50 minutes. At temperatures above 190°C, biodegradation decreases compared to lower temperatures and can even be lower than the control (Mottet et al., 2009; Stuckey and McCarty, 1984).

Effects on WAS

Floc and cell disruption

Temperatures from 100 up to 120°C were found to reduce particle size (Gao et al., 2013; Laurent et al., 2009b); which follows the trend observed in low-temperature pre-treatment. In contrast, at 170 and 190°C, the particle size increased compared to the untreated sample, which was explained by the creation of chemical bonds (Bougrier et al., 2006). In a follow-up study, Bougrier et al. (2008) observed a temperature threshold of 150°C, below which temperature worsened dewaterability and above which temperature improved it. The decrease and increase in particle size is also reflected in the dewatering properties of the digestate.

Already at 70-95°C permeabilization and cell destruction was observed (Prorot et al., 2011; Salton and Horne, 1951); and therefore it is expected that temperatures above 100°C will provoke extensive cell disruption and release of the intracellular content. Extensive solubilization seems to influence the observed increase in biodegradability for most of the studies reported (Table 2.4). However, as described below, care should be taken to avoid the negative effects of excessive temperatures. Moreover, considering the relatively low amount of bacterial mass in WAS (Table 2.1, 10-24%), the impact of temperature on other organic compounds needs to be considered.

Carbohydrates, proteins and humic substances

The melting point of sugars (at 170°C) causes caramelization, and thus the formation of organic acids, aldehydes, and ketones. Caramelization does not involve proteins and should not be confused with the Maillard reaction (Vaclavik and Christian, 2008). Above 170°C, degradation of sugars is expected to occur. However, Wilson and Novak (2009) observed that below 220°C, the effect of thermal hydrolysis on carbohydrates was solubilization, not degradation. This fact agreed with their observation that pure carbohydrate solutions were not largely converted to mono or dimeric sugar units at 220°C (Wilson and Novak, 2009). Regarding proteins, extensive denaturation is expected at such high temperatures as well as degradation at temperatures around 190°C and 220°C, since ammonia concentration had been observed to increase up to nine times compared to the control (Wilson and Novak, 2009). This matched with the fact that protein degradation of pure bovine serum albumin was observed for the same temperature range (Wilson and Novak, 2009). Below 170°C, evidence of extensive protein degradation has not been observed (Bougrier et al., 2008; Morgan-Sagastume et al., 2011). In particular, enzyme degradation is a pivotal factor in the loss of enzymatic activity at temperatures in excess of 80 °C (Daniel et al., 1996) and enzyme immobilization is able to increase the denaturation temperature only by around 25 °C (Unsworth et al., 2007). In addition, a decrease in the enzymatic activity is related to the temperature even for values below the denaturation temperature (Karshikoff et al., 2015). Thus, enzymatic activity is not expected to be a dominant mechanism under high-temperature pre-treatment of WAS, which usually works at temperatures in excess of 150°C and application times of 30 minutes. Finally, Wilson and Novak (2009) reported that from 130 to 220°C, the relative solubilization of polysaccharides was higher than that of proteins, which is the opposite to what has been observed for low-temperature pre-treatment. It is hypothesized that for a temperature >100°C most of the proteins are already solubilized, whereas the bound carbohydrates only start to be solubilized at 130°C. Also, the Maillard reaction could take place, likely to a higher extent as compared to temperatures below 100°C, since reaction rates increase with temperature (Dwyer et al., 2008). Finally, at temperatures above 110°C humic acids start to decompose (Kolokassidou et al., 2007), while at 150-180°C dissociation occurs (Bobleter, 1994; Garrote et al., 1999).

Hydrolysis rate and biodegradation

The hydrolysis rate increases after application of thermal hydrolysis (Bougrier et al., 2006; Gao et al., 2013) and so does the biodegradation, as observed in Figure 2.1 and Table 2.4. A parabolic behavior for WAS biodegradation as a function of pre-treatment temperature is observed in Figure 1, with the highest values in the range of 170-190°C. Indeed, it has been widely documented that the maximum methane production is found at temperatures around 170-190°C (Bougrier et al., 2008, 2007b; Pinnekamp, 1989; Stuckey and McCarty, 1984) despite the fact that COD solubilization continues to increase in proportion to temperatures up to 220°C (Mottet et al., 2009) (Table 2.4, entry t). Similarly, Bougrier et al. (2007b) and Pinnekamp (1989) tested pre-treatments at 190 and 220°C respectively, and the maximum biodegradation was found below those temperatures, in contrast to VS destruction, which increased in proportion to temperature. Such observations suggest that the pre-treated sludge is mineralized under harsh pre-treatment conditions (Zhen et al., 2014)

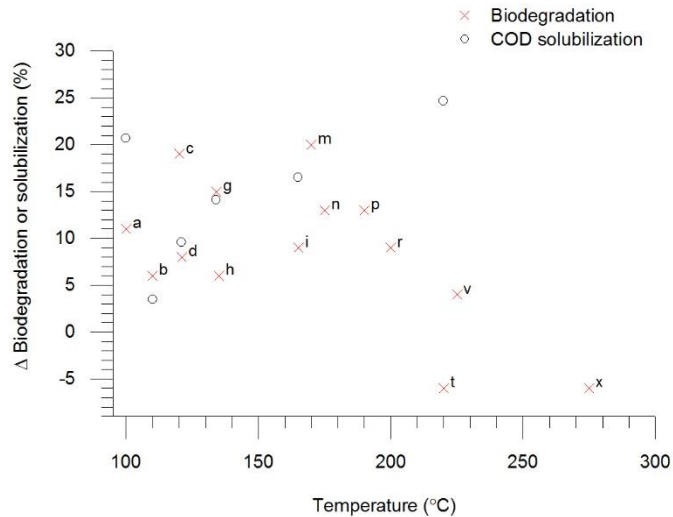

Figure 2.1 Change in biodegradation and COD solubilization due to thermal pre-treatment above 100 °C. Letters refer to entries in Table 2.4.

According to Stuckey and McCarty (1984) the observed peak in methane production could be caused by two competing mechanisms: the conversion of particulate organics into biodegradable dissolved matter, which increases methane yield; and the formation of soluble but refractory compounds that do not contribute to biogas production. The decline in methane production has been widely ascribed to Maillard reactions. Maillard reactions result in the formation of melanoidins (Neumann et al., 2016). Actually, due to their recalcitrant nature, melanoidins are also known as synthetic humic acids (Blondeau, 1989). The occurrence of the Maillard reaction produces color changes (Vaclavik and Christian, 2008), which correlate with the brownish supernatant of digested sludge observed by Bougrier et al. (2007b) at a temperature of 190°C. At 135°C or less (well below the methane production peak at 160-190°C), the formation of refractory products also already takes place as discussed for low-temperature pre-treatment, which could reduce WAS biodegradability. In contrast, it is likely that conditions up to 190°C promote a higher organic matter solubilization that outcompetes the formation of refractory compounds (Table 2.4, entry h). In addition, at 170°C, the caramelization of sugars starts, potentially producing the aldehyde furfural (C₅H₄O₂), which has been shown to inhibit anaerobic biological processes at a concentration of around 2 g/L (Ghasimi et al., 2016a). Thus, a temperature of around 190°C is postulated as the temperature above which the formation of refractory components outcompetes the formation of biodegradable soluble components, thereby reducing biodegradation. The exact temperature, however, depends on sludge composition, and probably other factors.

Table 2.3 Effects on the biodegradation of WAS after thermal pre-treatment ≥100°C.

Entry	Temperature, °C	Application time, min	Pressure, MPa	Soluble COD	Change in biodegradation (vs. control)	Change in biogas production (vs. control)	Reference
a	100	10	0.1	↑ from 4.1 to 24.8%	↑ 11% (from 12 to 23)		(Gao et al., 2013)
b	110	30	n/d	↑ from 8.7 to 12.2%	↑ 6% (from 47 to 53)		(Mottet et al., 2009)
c	120	10	0.1	↑ from 4.1 to 75.9%	↑ 19% (from 12 to 31)		(Gao et al., 2013)
d	121	30	0.152	↑ from 8.1 to 17.7%	↑ 8% (from 26 to 34)		(Kim et al., 2003)

e	130	15	n/d			↑ 14% (as CH ₄)	(Nielsen et al., 2011)
f	130	45	n/d			↑ ≈68%	(Pinnekamp, 1989)
g	134	20	0.312	↑ from 0.0 to 14.1%	↑ 15% (from 31 to 46)		(Gianico et al., 2013)
h	135	30	n/d		↑ 6% (from 49 to 55)		(Bougrier et al., 2007b)
i	165	30	n/d	↑ from 8.7 to 25.2%	↑ 9% (from 47 to 56)		(Mottet et al., 2009)
j	170	0*	n/d	40.5% (initial value not disclosed)		↑ 1.59 times	(Bougrier et al., 2006)
k	170	15	n/d			↑ 9.2% (as CH ₄)	(Nielsen et al., 2011)
l	170	45	n/d			↑ 74%	(Pinnekamp, 1989)
m	170	60	n/d		↑ 20% (from 25 to 45)		(Valo et al., 2004)
n	175	60	n/d		↑ 13% (from 48 to 61)		(Stuckey and McCarty, 1984)
o	190	0*	n/d	49.0% (initial value not disclosed)		↑ 1.59 times	(Bougrier et al., 2006)
p	190	15	n/d		↑ 13% (from 49 to 62)		(Bougrier et al., 2007b)
q	190	30	n/d	≈63% (initial value not disclosed)		↑ ≈2.6 times	(Bougrier et al., 2008)
r	200	60	n/d		↑ 9% (from 48 to 57)		(Stuckey and McCarty, 1984)
s	210	30	n/d	≈67% (initial value not disclosed)		↑ ≈2.1 times	(Bougrier et al., 2008)
t	220	30	n/d	↑ from 8.7 to 33.4%	↓ 6% (from 47 to 41)		(Mottet et al., 2009)
u	220	45	n/d			↑ ≈11%	(Pinnekamp, 1989)
v	225	60	n/d		↑ 4% (from 48 to 52)		(Stuckey and McCarty, 1984)
w	250	60	n/d		=		(Stuckey and McCarty, 1984)
x	275	60	n/d		↓ 6% (from 48 to 42)		(Stuckey and McCarty, 1984)

* No holding time
n/d: not determined

Limiting factors, advantages and perspectives

Attention should be given to the effect of the refractory solubilized fraction resulting from thermal hydrolysis, as it may pose negative effects when returned back to the wastewater headworks. A way to minimize the effects of refractory compounds is to increase digestion times (whenever possible) (Stuckey and McCarty, 1984), provided the methanogenic consortia are able to adapt to these compounds. Adaptation may occur by allowing sufficient time for developing the required hydrolytic enzymes (Ghasimi et al., 2016b).

Thermal hydrolysis has been observed to increase biogas production, with the largest impact on low-loaded activated sludge processes, for sludge samples with low initial biodegradation (Bougrier et al., 2008; Pinnekamp, 1989) and for digested sludges that are post-treated and then re-digested (Pinnekamp, 1989). In addition to its original objective of sludge sterilization (implying suitability for land disposal if regulations allow), thermal hydrolysis also increases the dewaterability of the digestate (at above 150°C) and results into high VS removal. Compared to low-temperature pre-treatment, thermal hydrolysis cannot operate using only low-quality waste heat (≤80°C), high quality heat (>100°C) is also

required, which can negatively impact the energy balance as observed in Table S2-1 and Table S2-2. To get a closed heat balance (or as closed as possible) dewatered WAS with a high VS concentration (>16%) should be fed to the pre-treatment, instead of thickened or dewatered sludge with a VS concentration of around 3-6%, as compared to low-temperature pre-treatment Table S2-2. Moreover, in many cases the required minimum VS concentration had to be 20-25%, or some primary sludge had to be co-digested to get a closed heat balance during thermal hydrolysis.

2.2.4 Microwave pre-treatment

Process description and mode of action

Microwaves are high-frequency (around 2.45 GHz) electromagnetic waves, which create a changing electromagnetic field. This causes rapid alignment and realignment of dipoles in polar molecules (such as water and some EPS molecules), and thus generates friction that liberates heat (Vaclavik and Christian, 2008). In addition to the thermal effect, an “athermic” effect related to the breaking of the polymeric network due to the rotation of molecules has been hypothesized (Eskicioglu et al., 2006). Nonetheless, it has been demonstrated that under identical experimental conditions (heating/cooling rates and net absorbed energy), athermal effects do not exist, or at least, are insignificant compared to the thermal effects (Hosseini Koupaie and Eskicioglu, 2016; Mehdizadeh et al., 2013; Sólyom et al., 2011; Vergine et al., 2014).

Similar to conventional thermal pre-treatment (heat transfer by convection), temperature increase is the most relevant parameter during microwave pre-treatment (Hosseini Koupaie and Eskicioglu, 2016; Mehdizadeh et al., 2013). Increase in biodegradation is in proportion to applied temperature, for the low-temperature range (65-85°C) (Kennedy et al., 2007) as well as for the high temperature range 110-175°C (Toreci et al., 2011, 2010). Other important factors are the temperature increase rate, or ramp rate (Hosseini Koupaie and Eskicioglu, 2016) and the sludge solids concentration, as it affects the absorption of microwaves (Eskicioglu et al., 2007b) and thus the energy actually delivered to the sample.

Effects on WAS

Floc and cell disruption

Similarly to low-temperature pre-treatment, the mean particle size of the pre-treated sludge seems to decrease under microwave application (Kennedy et al., 2007; Yi et al., 2014). Unfortunately, no studies were found regarding the relationship between particle size distribution and temperature increase, at temperatures higher than 100°C, although a further decrease in particle size is expected at temperatures around 150°C, followed by an increase after this temperature, as has been reported for thermal hydrolysis.

Cella et al. (2015) found that the highest microbial destruction occurred at 2.62 kJ/g TS at a temperature of 80°C and 9 minutes of application time, which lowered the live/dead ratio from around 3 for the control to around 0.25 for the pre-treated sample. An additional input of energy did not cause significantly higher microbial death. Eskicioglu et al. (2007a) postulated that cell disruption is due to the absorbance of microwaves in the lipid bilayer of cell membranes. Several studies have reported an increase in cell disruption by using microwaves as compared to conventional heating at the same final temperature, the difference potentially being explained by the aforementioned athermal effect (Eskicioglu et al., 2007c; Hong et al., 2006, 2004; Kakita et al., 1995). However, in those studies, either

the temperature increase rate or the energy actually absorbed by the sample was not strictly controlled. As a consequence, a higher energy input could have been actually delivered resulting in a higher cell death. Therefore, it is concluded that cell disruption exists during microwave pre-treatment, but the treatment is dominated by thermal effects, just as for conventional thermal pre-treatment.

Carbohydrates, proteins and humic substances

The observation that merely thermal effects are determining during microwave pre-treatment is also confirmed by trends observed for both thermal and microwave pre-treatments:

- Proportional increase in soluble COD at temperatures below 100°C (Eskicioglu et al., 2007c; Kennedy et al., 2007) as well as above 120°C (Eskicioglu et al., 2009; Toreci et al., 2009). Specifically, a proportional increase in the concentration of soluble sugars, protein and humic acids at 50-160°C (Eskicioglu et al., 2007a; Mehdizadeh et al., 2013).
- Higher relative solubilization of proteins compared to carbohydrates (Eskicioglu et al., 2007c; Uma Rani et al., 2013). No degradation of proteins and sugars up to 80°C (8.23 kJ/gTS) (Appels et al., 2013).
- Initial increase of reducing sugars in the supernatant at 50 and 75°C and subsequent decrease at 96°C, probably explained by the occurrence of the Maillard reaction (Eskicioglu et al., 2007a).

Hydrolysis rate and biodegradation

In contrast to conventional thermal pre-treatment, conflicting results have been observed regarding the hydrolysis rate. Park et al. (2004) and Hosseini Koupaie et al. (2017) observed an increase; Eskicioglu, et al. (2007b) found no change; and Toreci et al. (2011) found a decrease. The latter could be explained by inhibition caused by toxic by-products formed during microwave pre-treatment, because temperatures up to 175°C had been used. Another possible explanation is the use of non-acclimated inoculum during batch digestion tests. Regarding sludge biodegradation, results match with observations for low and high temperature pre-treatment. Most of the studies observed an increase in biodegradation (Table 2.5), although some papers reported no increase (Cella et al., 2015; Eskicioglu et al., 2008).

Table 2.5 Effects on the biodegradation of WAS after microwave pre-treatment.

Entry	Temperature, °C	Application time, minute	Irradiation energy, kJ/L	Specific energy (E _s), kJ/gTS	Change in biodegradation (vs. control)	Change in CH ₄ production (vs. control)	Change in biogas production (vs. control)	Reference
a*	60	7	1029	16.07 (ca.)	↓ 3% (from 53 to 50)			(Eskicioglu et al., 2008)
b*	80	8	1175	18.37 (ca.)	↑ 1% (from 53 to 54)			(Eskicioglu et al., 2008)
c*	80	3.5	336	8.23				(Appels et al., 2013)
d*	85	4.5	493	16.42 (ca.)		↑ 16%		(Kennedy et al., 2007)
e	91.2	7	588	19.55		↑ 30%		(Park et al., 2004)
f*	96	3	450	21.65 (ca.)			↑ 17%	(Eskicioglu et al., 2007b)
g*	96	6	900	17.51 (ca.) as kJ/gSS	↑ 10% (from 33 to 43)			(Coelho et al., 2011)
h*	100	9	1322	20.66 (ca.)	↑ 15% (from 53 to 68)			(Eskicioglu et al., 2008)
i	120	10	1470	22.96 (ca.)	↑ 1% (from 53 to 54)			(Eskicioglu et al., 2008)
j	130	46	3335	81.54 (ca.)	↑ 9% (from 46 to 55)			(Chi et al., 2011)
k	160	16	2880	501.8 (ca.) as kJ/gSS		↑ 11%		(Doğan and Sanin, 2009)
l	190	39	2830	69.13 (ca.)	↑ 11% (from 46 to 57)			(Chi et al., 2011)
m	n/d	n/d	975	38.08		↑ 46%		(Martinez et al., 2016)
n	n/d	n/d		20		↑ 6%		(Serrano et al., 2016)

*Performed with mixed sludge (WAS=58%; primary sludge =42%, by volume)

n/d= not disclosed

ca. = calculated value based on the parameters of the study

The effect of the temperature increase rate during pre-treatment on sludge biodegradation should not be neglected. It has been observed that a slower temperature increase, enhances methane production for both low and high temperature scenarios (Eskicioglu et al., 2009; Hosseini Koupaie and Eskicioglu, 2016; Park and Ahn, 2011; Toreci et al., 2011). This could be related to the application time-temperature dependence, that was observed by Hosseini Koupaie et al. (2017) for microwave pre-treatment under 90-120°C and with application times of 1 to 2 hours. However, insufficient studies, on the time-temperature dependency with microwave pre-treatment, were found in literature to draw general conclusions regarding this mechanism.

Limiting factors, advantages and perspectives

Despite the inherent differences between microwave and ultrasonic (US) pre-treatments, comparisons have been carried out under similar specific energy consumption. For microwaves, applying 2.62 kJ/g TS at a temperature of 80°C and 10 minutes of application time, and US pre-treatment, applying 2.37 kJ/g TS at a temperature <35°C, it was found that microwaves caused a fourfold to fivefold greater cell death, but this did not result in significantly different biodegradation (Cella et al., 2015). Westerholm et al. (2016) made a similar observation. This suggests that both microwave and ultrasonic pre-treatment result in comparable outcomes regarding biodegradation. Applying an alternative electromagnetic frequency (13.56 MHz versus the conventional 2.45 GHz) did not change the biogas production rate and biodegradation significantly (Hosseini Koupaie et al., 2017), although it was two times more energy efficient compared to the conventional frequency. A potential drawback of microwave pre-treatment is the observed short term inhibition of digestion after pre-treatment (Eskicioglu et al., 2007b; Toreci et

al., 2011), however no studies have been performed to further understand its cause. Interestingly, microwave pre-treatment has been reported to improve the dewaterability of the digestate at temperatures below 96°C (Coelho et al., 2011; Eskicioglu et al., 2007b; Wang and Li, 2016), in contrast to the results of low-temperature thermal pre-treatment. Based on the discussions in previous sections, similar improvements to anaerobic digestion can be achieved with low-temperature or thermal hydrolysis pre-treatments. Furthermore, microwave pre-treatment requires a significantly higher energy expense (Table S2-1), due to the fact that electricity is required, in contrast to the waste heat required for low-temperature pre-treatment.

2.2.5 Freezing and thawing

Process description and mode of action

Freeze and thaw consists of the freezing of sludge, usually at temperatures around -20°C for several hours and a subsequent thawing process at room temperature. The formation of ice crystals causes physical damage to the cells (Vaclavik and Christian, 2008). The sequence of mechanisms is: a) at 0°C, ice crystals are formed in the extracellular solution. Intracellular content remains liquid as it contains fluids with lower freezing points compared to extracellular content (Thomashow, 1998). The ice front pushes particulate matter together, forming clusters; b) solute concentrations just outside the cell increase due to the freezing of the extracellular solution. This causes osmotic pressure that leads to cell dehydration and shrinking (Wang et al., 2001); c) as freezing time increases or temperature is further decreased, to between -2 and -10°C, the intracellular content freezes and expands due to internal ice formation that then leads to cell lysis (Thomashow, 1998).

Very limited research focused on increasing methane production with this method has been reported. Most of the relevant studies focused on dewatering effects. Temperature, freezing rate and pre-treatment time (curing time) are relevant operational parameters that affected dewaterability (Hu et al., 2011; Vesilind and Martel, 1990; Wang et al., 2001). Lower freezing rates and colder temperatures result in better dewatering (Hu et al., 2011; Vesilind and Martel, 1990). Refreezing, in multiple freeze and thaw cycles, enlarges ice crystals, contributing to further cell disintegration (Vaclavik and Christian, 2008).

Effects on WAS

Floc and cell disruption

It has been reported that the ice front formed during freezing of WAS squeezes the particulate fraction together into larger particles that tend to keep their new size after thawing (Gao, 2011; Wang et al., 2001). Other studies showed that freeze and thaw pre-treatment reduced the particle size of the sludge flocs and increased the settleability. Similarly, when subjected to cooling the proteins precipitate or aggregate (Chang et al., 1996; Heller et al., 1999; Yu et al., 2006). This suggests compaction of the sludge flocs due to the freezing process (Hu et al., 2011). As almost all studies report an increase in dewaterability, but with different trends in the modification of particle sizes, both increase in particle size and increase in density could be the mechanism behind dewaterability increase.

The freeze and thaw pre-treatment causes a decrease in the fraction of viable cells (Diak and Örmeci, 2016; Wang et al., 2001). Slow freezing is more preferable than rapid freezing or excessively lower temperatures (Wang et al., 2001). Authors concluded that at -80°C, the freezing speed was so rapid that

some bacteria survived due to the prevention of the elution of proteins and carbohydrates. Cell survival at freezing temperatures could be due to the presence of cryoprotectant components, such as proteins and fats and glycerol (Montusiewicz et al., 2010).

Carbohydrates, proteins and humic substances

COD solubilization increases linearly with freezing time, suggesting that long retention times could be required to have significant solubilization (Hu et al., 2011). Wang et al. (2001) observed a 25-fold increase in soluble proteins and an approximately 4-fold increase in soluble carbohydrates after 24 hours of freezing at -10°C . They also observed a higher degree of solubilization in the case of freezing at -10°C as compared to freezing at -80°C . This was related to higher cell disruption at higher temperatures. Even though protein denaturation occurs as a result of freezing, freezing does not completely stop enzyme activity (Vaclavik and Christian, 2008). Regarding carbohydrates, the expelling of water from starch (an effect of the retrogradation reaction) is more likely to occur in WAS that is exposed to the effects of freeze–thaw cycles (Vaclavik and Christian, 2008).

Hydrolysis rate and biodegradation

No information was found concerning the effect of freeze and thaw pre-treatments on the hydrolysis rate. However, an increase is expected since cell disruption and change in particle size occurs. In the few studies regarding biogas potential, increased biogas production has been reported (Jan et al., 2008; Montusiewicz et al., 2010; Pabón Pereira et al., 2012).

Limiting factors, advantages and perspectives

Similar COD solubilization was observed for freeze and thaw and high-temperature thermal (103°C) pre-treatment (Gao, 2011). Unfortunately, the anaerobic biodegradability and biogas production was not studied. The only successful freeze and thaw systems are found in natural freezing and thawing systems in open beds (Hellström, 1997; Kinnunen et al., 2014; Vesilind and Martel, 1990). In these sludge beds, the sludge is spread into thin layers during the winter months and allowed to freeze, while in warmer weather the sludge thaws and the water drains out, leaving a dry WAS (Wang et al., 2001). Although this mechanism is beneficial for improving dewaterability, it could cause a decrease in the biodegradation of sludge, because soluble COD also leaks out if the sludge is not in an enclosed volume. Since no energy input is required and an increase in methane production is expected, freeze and thaw using naturally occurring conditions has a positive energy balance (Table S2-1). However, this technique is restricted to cold regions during the coldest seasons and is dependent on the actual climatic conditions (not all winters are similarly cold). Also, in order to reduce the size of the bed, research on applicable exposure times need to be performed. Artificial freezing does not seem to be a practical option, because of the amount of electricity required, and the hypothetical large freezers for storing the sludge. For instance, active freezing of sludge from 10 to -25°C assuming a total solids concentration of 40 g/L and a coefficient of performance of 2.75 (Taib et al., 2010), would demand an expense of 4.25 kJ/gTS in electric energy. Nonetheless, freeze and thaw increases the biomethane potential of WAS, while also probably improving the dewaterability of the digestate. Moreover, in contrast to other pre-treatment techniques, the formation of refractory compounds or undesirable by-products is probably absent at freezing temperatures.

2.2.6 Ultrasonic pre-treatment

Process description and mode of action

Ultrasonic pre-treatment results in cavitation, a disturbance in the liquid resulting in the formation, growth, and implosion of bubbles (Chatel, 2016). In order for cavitation to occur, weak points in the liquid must exist, such as suspended particulate matter (Chatel, 2016). The efficacy of ultrasonic pre-treatment of WAS depends on ambient conditions and operational parameters (Delmas et al., 2014). Depending on the selection of ultrasonic parameters, the sudden collapse of bubbles creates shear forces and/or formation of hydroxyl radicals.

Parameters such as frequency, ultrasonic density (Equation 2.2), temperature and VS concentration should be considered for a complete picture of the performance of ultrasonic pre-treatment. One of the most widespread operational parameters for ultrasonic pre-treatment of WAS is the specific energy requirement, E_s (Equation 2.3), an umbrella term encompassing power, volume of the sample, application time and the concentration of solids. Although useful for assessing the energy consumption, it should be employed carefully as it does not replace the detailed selection of the main parameters of ultrasonic pre-treatment. Table 2.6 lists the relevant parameters and their effects during sonication of WAS.

$$D \left[\frac{kW}{L} \right] = \frac{\text{Power (kW)}}{\text{Volume (L)}} \quad (\text{Eq. 2.2})$$

$$E_s \left[\frac{kJ}{gTS} \right] = \frac{D \left(\frac{kW}{L} \right) \times \text{time (s)}}{\text{Solids concentration} \left(\frac{gTS}{L} \right)} \quad (\text{Eq. 2.3})$$

Table 2.6 Parameters with influence in the sonication of WAS.

Parameter, (unit)	Remarks
Frequency, (kHz)	<p>Frequency determines whether cavitation or formation of hydroxyl radicals dominates: low frequencies (20-80 kHz) lead to physical effects (shockwaves, microjets, microconvection) (Chatel, 2016; Pilli et al., 2011); while high frequencies (150-2000 kHz) favour the production of hydroxyl radicals (Chatel, 2016; Tiehm et al., 2001).</p> <p>For WAS ultrasonic pre-treatment, the range of 20 to 41 kHz has been commonly used.</p> <p>Between 41 and 3217 kHz, higher particle size reduction and supernatant turbidity was observed at 41 kHz (Tiehm et al., 2001). Recently, the use of audible frequencies (<20kHz) has been assessed with promising results. At lower frequencies, like 12 kHz, higher COD solubilization has been observed than at 20 kHz (Delmas et al., 2014; Tuan et al., 2016; R. Wang et al., 2016a). Jiang et al. (2009) however had the highest COD solubilization at 25 kHz of the tested 19, 25, 40 and 80 kHz.</p>
Ultrasonic density, acoustic power or power density, D , (kW/L)	<p>Power density is part of the parameters included in the calculation of the specific energy (Eq. 3). It has been observed that under the same value of E_s, the higher the power density, the higher the solubilization (Pérez-Elvira et al., 2009; Show et al., 2007).</p>
Temperature	<p>Cavitation increases the temperature of the medium as a function of the sonication time (Chatel, 2016; Nguyen et al., 2016) and power density (Rombaut et al., 2014).</p> <p>Temperature uncontrolled sonication led to higher COD solubilization compared to temperature controlled sonication (Tuan et al., 2016). However, the effect of shear forces by cavitation decreases at increasing temperatures, so it should be kept below 80°C (Delmas et al., 2014; Huan et al., 2009; Tuan et al., 2016).</p>
Solids concentration, (gTS/L)	<p>There is an optimum in the range of 1-3% TS for solubilization (Sahinkaya, 2015; Show et al., 2007) and biodegradation (Pilli et al., 2016). According to (Show et al., 2007), an excess of solids in sludge results in high energy loss during sonication, thus reducing the effectiveness of pre-treatment.</p>

Application time, (s)	It has been observed for temperature controlled ultrasonic pre-treatment that increasing pre-treatment time over 60 minutes had essentially no effect on the sludge characteristics (Chu et al., 2001). However, for temperature uncontrolled ultrasonic pre-treatment, the effects of increasing pre-treatment time are increases in temperature and higher cellular death (Zielewicz, 2016).
-----------------------	--

Effects on WAS

Floc and cell disruption

Ultrasonic pre-treatment has been used as a dispersion technique for aggregates (Foladori et al., 2007; Jorand et al., 1995) such as WAS flocs. A reduction in particle size diameter is expected, which would make the organic matter more accessible for enzymatic attack (Jorand et al., 1995; Vavilin et al., 2008).

For temperature controlled sonication, particle size decreased as the dosage of specific energy increased (Feng et al., 2009). This in turn results in an increase in hydrolysis rate, as will be described below.

An effect of ultrasonic pre-treatment is the break-up or damage of the bacterial cell wall (Jorand et al., 1995). Indeed, cell disruption has been documented by flow cytometry of WAS as presented in Table 2.7. Entries a and b, were performed with very low TS concentrations that are not representative of thickened WAS that is used for AD, yielding to excessive energy values. However, Cella et al. (2015), employed sewage sludge at 42 gTS/L and found that even though the percentage of damaged bacterial cell walls increased from around 33 to 50% (Table 2.7, entry c), the cell death did not increase overall WAS biodegradation; which might be attributed to the relatively low amount of cells in WAS (Cella et al., 2015). Nonetheless, more detailed research is necessary to determine the specific energy required to damage or rupture cell walls in thickened WAS.

Table 2.7 Effect of ultrasounds application in cell disruption.

Entry	Solids concentration	Ultrasonic density, (kW/L)	Specific energy (E _s)	Damaged cells (%)	Comment	Reference
a	0.00253 g TSS/L*	0	0	13	Control	(Guo et al., 2014)
		2.0	95,000 kJ/gTSS	20	Sonicated sample	
b	0.006-0.0088 gTSS/L*	0	0	18	Control	(Foladori et al., 2007)
		0.3-1.5	20,000 kJ/gTSS	25	Sonicated sample	
c	42 gTS/L	0	0	≈33	Control	(Cella et al., 2015)
		1	2.37 kJ/gTS	≈50	Sonicated sample	

* Low solids concentrations are caused by dilution

Carbohydrates, proteins and humic substances

During ultrasonic pre-treatment, for both temperature-controlled and uncontrolled conditions, the solubilization of proteins is higher compared to carbohydrates (Table 2.8), which matches with some findings from thermal pre-treatment below 100°C. During temperature-controlled ultrasonic pre-treatment, only a marginal increase in VFA concentration was observed (Cella et al., 2015). It remains unclear whether sonication is able to break down carbohydrates and proteins, as well as its effect on humic substances, which leaves ample room for further research.

Table 2.8 Release of biopolymers after ultrasonic pre-treatment.

Entry	Temperature, °C	Ultrasonic density, (kW/L)	E_s , kJ/gTS	Change in soluble carbohydrate (vs. control)	Change in soluble protein (vs. control)	Change in soluble humic substances (vs. control)	Reference
a	30	0.65	2.5-21	↑≈9 times	↑≈23 times		(Tian et al., 2015b)
b	“un-controlled”	0.1	100	↑11.4 times	↑ 13.3 times	↑ 3.9 times	(Jaziri et al., 2012)
c	“no increase detected”	0.5	2.209	↑ 8.0 times	↑ 10.9 times		(Braguglia et al., 2015)
d	“no increase detected”	0.5	8.838	↑25 times	↑25 times		(Braguglia et al., 2015)
e	Not disclosed	0.18	13.14 (as kJ/gSS)	↑0.5 times			(Brown and Lester, 1980)

Hydrolysis rate and biodegradation

Hydrolysis rate increases with ultrasonic pre-treatment (Braguglia et al., 2012; Kianmehr et al., 2013; Zorba and Sanin, 2013). This can be ascribed to the inherent floc dispersion (de-agglomeration) which leads to an increased surface area; and also because of better mixing and diffusion of the components (Bougrier et al., 2006; D.-H. Kim et al., 2013; Rombaut et al., 2014; Sotodate et al., 2009).

Regarding sludge biodegradation, due to the associated increase in temperature (which could reach up to 70°C) under uncontrolled conditions, an analysis must consider the effect of temperature in order to differentiate between thermal and ultrasonic effects on the biodegradation. As shown in Table 2.9, when temperature was kept below 45°C, the increase in biodegradation was in the range of 1-5.5% (entries a to d), even though extensive COD solubilization occurred (Kianmehr et al., 2013). An explanation could be that most of the cell walls are only partially damaged or ruptured during ultrasonic pre-treatment and because biopolymers are only solubilized but not degraded. However, the study from Braguglia et al. (2015) (entry e) is an exception to this trend, as the increase in biodegradation was 14%. In addition, a full-scale study in Nieuwgraaf WWTP, The Netherlands, where about 35% of the total WAS stream was exposed to sonication at temperatures below 30°C (the temperature increase was 7°C) and $D=0.096$ kW/L, resulted in a E_s of about 8 kJ/gTS. No difference between the sonication process and the untreated process was observed, neither for soluble COD increase nor for VS reduction (STOWA, 2013). On the other hand, when control of temperature is not carried out (entries f-g), biodegradation increased in the order of 7-18%, as well as methane production (entry h). It could therefore be inferred that thermal effects most likely causes the difference in sludge biodegradation. According to Salsabil et al. (2009), the production of biogas was proportional to E_s in the range 3.6-108 KJ/gTS, thus a higher energy input may result in remarkable increases in biodegradation. Nonetheless, E_s values of 14.3 and 25.9 kJ/gTS required hypothetical sludge biodegradation of 160 and 261% respectively, resulting in a negative energy balance (Table S2-3).

Table 2.9 Effects of ultrasonication on WAS biodegradation.

Entry	Temperature	Ultrasonic density, (kW/L)	E_s , kJ/gTS	Change in biodegradation (vs. control)	Change in CH ₄ production (vs. control)	Notes	Reference
Temperature control							
a	Started at 25°C and “not increased significantly”	1.9	3.8	↑ 3% (from 20 to 23)			(Seng et al., 2010)
b	T<45°C	3.7		↑ 1-3%			(Kianmehr et al., 2013)
c	T<35°C	0.165	2.37	↑ 2% (from 41 to 43)		mix of primary sludge and WAS (33:67)	(Cella et al., 2015)
d	T<30°C	0.65	9	↑ 6% (from 56 to 62)		mix of primary sludge and WAS (1:1)	(Tian et al., 2015b)
e	“no temperature increase detected”	0.6	4.42	↑ 14% (from 34 to 48)		mix of primary sludge and WAS (33:67)	(Braguglia et al., 2015)
No temperature control							
f	No-controlled	7.5		↑ 7% (from 36 to 43)			(D.-H. Kim et al., 2013)
g	No-controlled	≈13.3	2.57	↑ 18% (from 42 to 60)			(Pérez-Elvira et al., 2010)
h	up to 70°C	0.51			↑ 74%		(Apul and Sanin, 2010)

The previous results suggest that temperature-controlled ultrasonic pre-treatment has lower methane yield compared to temperature-uncontrolled conditions. Tuan et al. (2016), already suggested that a better performance is obtained from the coupled effect between sonic waves and temperature. In other words, the effect of ultrasonic pre-treatment alone (i.e., excluding thermal effects) barely increases the WAS biodegradation, while an increase in temperature results in higher biodegradation, probably described by the mechanisms of thermal pre-treatment below 100°C. Finally, application of ultrasonic pre-treatment at 80°C resulted in similar COD solubilization to the sole application of temperature at 80°C (Delmas et al., 2014).

Limiting factors, advantages and perspectives

The energetic efficiency of ultrasonic pre-treatment is a burden because two energy conversions (with their respective energy losses) are carried out: conversion of electrical energy to mechanical vibration, and the conversion of mechanical vibration into cavitation (Pérez-Elvira et al., 2010). For instance, Chatel (2016) remarked that the conversion of electrical energy provided by the generator into acoustic energy transmitted to the medium is currently about 30-40% efficient for low-frequency ultrasound. This could be a reason why ultrasonic pre-treatment generally leads to negative electric energy balances, as observed in Table S2-1. The main drawbacks of ultrasonic pre-treatment are thus a) electricity is required instead of heat and; b) a WAS solids concentration below 4% is required, as a higher solids concentration decreased the efficiency of the ultrasonic pre-treatment (Pilli et al., 2016; Sahinkaya, 2015). Even though temperature-controlled ultrasonic pre-treatment results in a marginal rise in biodegradation, better outcomes are observed for temperature-uncontrolled ultrasonic pre-treatment.

However, the observed increases in biodegradation are still less than those achieved by low-temperature pre-treatment.

2.2.7 Hydrodynamic cavitation, milling and homogenization

Process description and mode of action

In addition to ultrasonic pre-treatment, hydrodynamic cavitation, milling and homogenization are also examples of mechanical pre-treatments. Cavitation can be produced by ultrasonic pre-treatment, but also by the flow of liquid under controlled conditions through venturi tubes or orifice plates (Kumar and Pandit, 1999; Lee and Han, 2013). The resulting cavitation bubbles result in disintegration of the sludge (Hirooka et al., 2009). According to Kim et al. (2008), the inclination angle and the number of venturi constrictions have been shown to be factors that affect the amount of COD solubilization.

Sludge milling consists of a grinding mechanism in which moving beads impact the sludge particles by provoking their breakage. Jung et al. (2001) observed that the collision frequency between the moving beads correlated with sludge solubilization rates.

Finally, homogenization is a method for cell disruption, originally developed for the stabilization of food and dairy emulsions (Zhang et al., 2012). During homogenization, sludge is pressurized to between 30 and 150 MPa for 3-30 minutes, after which the sample is accelerated through a convergent section and collides on an impact ring. As a result, the effects of pressure gradient, cavitation and shear are present (Zhang et al., 2012). During homogenization, pressure is the most significant factor for increasing the solubilization of COD (Li et al., 2014; Wahidunnabi and Eskicioglu, 2014; Zhang et al., 2012), while the number of homogenization cycles is less relevant (Zhang et al., 2012).

Milling and homogenization can result in temperature increases up to 43°C (Jung et al., 2001; Zhang et al., 2012). This is lower than the threshold temperature required to cause significant changes in the physicochemical characteristics of WAS (see section 2.2.1). Furthermore, mechanical pre-treatments use electricity as energy input.

Effects on WAS

Floc and cell disruption

Homogenization (temperature not mentioned) reduced the floc size: the median size of WAS was reported to become 3 to 4 times smaller (Fang et al., 2015). Similarly, a reduction in particle size was observed for milling (Lajapathi Rai et al., 2008). Cell disruption has also been reported; ball milling with temperature control, at an energy input of around 5 kJ/gTS, achieved a cell inactivation of 30%, while it increased to 80% at 35 kJ/gTS (Lajapathi Rai et al., 2008). This shows that for extensive cell disruption to occur, energy inputs must be substantially high.

Carbohydrates, proteins and humic substances

During ball milling, COD solubilization increased in proportion to energy input, similar to cell disruption (Lajapathi Rai et al., 2008). The same trend was observed for homogenization at pressures up to 60 MPa (Fang et al., 2015). Nonetheless, the solubilization extent was limited to about 17% for a homogenization pressure of 80 MPa and $E_s=5.351$ kJ/gTS, while both protein and polysaccharide concentrations in sludge supernatant increased by a factor 1.4 (Zhang et al., 2012). For a

depressurization at 0.52 MPa (75 psi), the soluble COD concentration in pre-treated sludge increased by $20 \pm 2\%$, while soluble protein increased by 72% relative to the control (Dhar et al., 2011). The solubilization values of some mechanical pre-treatments are considerably lower compared to other techniques with comparable energy inputs (Braguglia et al., 2015; Tian et al., 2015b). No information could be found regarding a possible change in the structure of carbohydrates, proteins and humic acids during the mechanical pre-treatments.

Hydrolysis rate and biodegradation

Limited increases in hydrolysis rate, e.g. from 0.14 to 0.16 d⁻¹, have been observed for homogenization and hydrodynamic cavitation (Dhar et al., 2011; Elliott and Mahmood, 2012; Lee and Han, 2013). Recorded increases in biodegradation were from 38 to 43% (Dhar et al., 2011) and from 13 to 15% (Lee and Han, 2013) for the same pre-treatments.

Limiting factors, advantages and perspectives

For ball milling and homogenization, it has been observed that a higher concentration of solids in the sample resulted in lower solubilization (Baier and Schmidheiny, 1997; Zhang et al., 2012). For hydrodynamic cavitation with temperature control, Kim et al. (2008) observed that a higher concentration of solids (in the range 0.5 to 4%TS) resulted in higher solubilization. The latter behavior is contradictory to what has been found for ultrasonic pre-treatment (section 2.6), on which an optimum value for solubilization has been found to be around 3%TS. It could be hypothesized that ultrasonic pre-treatment is limited in its ability to generate cavitation in concentrated sludge, whereas hydrodynamic cavitation may be less dependent of the solids concentration of WAS. In fact, the few comparisons between hydrodynamic and ultrasonic cavitation are contradictory: Lee and Han (2013) compared ultrasonic pre-treatment (apparently with no temperature control) and hydrodynamic cavitation using WAS with about 1% TS at comparable specific energy values, and found that COD solubilization was similar in both cases. In contrast, Kim et al. (2008) found that ultrasonic pre-treatment reached three times higher COD solubilization as compared to a venturi using WAS at 4% TS.

During ball milling the solubilization of organic material was not in-line with the enhanced biodegradation (Baier and Schmidheiny, 1997; Elliott and Mahmood, 2012; Wett et al., 2010). In all cases, the biodegradation remained low. This observation is puzzling and deserves further research, because of its significant implications for volume reduction in full scale-facilities. Finally, despite more information being required regarding the energy consumption of hydrodynamic cavitation, milling and homogenization, these techniques seem to result in a WAS biodegradation and energy requirements that are fairly comparable to other techniques, such as low-temperature pre-treatment. However, relevant differences are that energy must be provided in the form of electricity and there is the requirement of pressurized vessels for homogenization and hydrodynamic cavitation.

2.2.8 Chemical pre-treatments

This category is sub-divided into alkaline pre-treatment, acid pre-treatment and advanced oxidation processes that use radicals to decompose organic matter.

2.2.8.1 Alkaline pre-treatment

Process description and mode of action

Alkaline pre-treatment consists of the increase in pH of the WAS matrix by means of an alkali, such as NaOH or Ca(OH)₂, amongst others. The structure, surface properties and electrostatic charge of extracellular polymeric substances (EPS) are modified due to pH changes (Wang et al., 2012). The physicochemical properties of EPS depend on whether its functional groups, such as carboxylic or sulfate groups (pKa ≈ 4, Wang et al. 2012) and amino groups, (pKa 7.0–9.0, Wang et al. 2012) are deprotonated or protonated. A pH increase caused by alkaline pre-treatment could therefore have a pivotal effect on the structure of the WAS matrix.

One effect of alkaline pre-treatment is the dissociation of acidic groups in EPS, which causes electrostatic repulsion between the negatively charged EPS (Wingender et al., 1999) and increases its solubilization. The repulsion is mostly due to the ionization of carboxyl and amino groups from proteins (Liao et al., 2002). Saponification of the lipid by-layer of the cell membrane (and a subsequent release of intracellular contents) and protein denaturation due to extreme pH values is another effect (Vaclavik and Christian, 2008). Relevant control parameters are the target pH and the (amount of) reagent used. Application times in the order of two hours are common; it has been found that around 60-82.9% of the total COD is released after 10-24 hours (Chang et al., 2002; Li et al., 2008).

The type of reagents used, especially the metal salts, also affect dewaterability of digestate and VS reduction. For instance higher COD solubilization has been observed for sodium hydroxide compared to calcium hydroxide when using the same dose (in charge equivalents) (Li et al., 2008; Rajan et al., 1988). Similarly, at pH 12 with NaOH, KOH, Mg(OH)₂ and Ca(OH)₂ the COD solubilization values were 39.8%, 36.6%, 10.8% and 15.3%, respectively (Kim et al., 2003). Also, a higher VS removal has been observed for NaOH (34%) compared to Ca(OH)₂ (30%) (Ray et al., 1990). The same effect has been measured for the WAS biodegradation: Ray et al. (1990) observed that under the same alkali dose the use of NaOH caused a significantly higher biogas production compared to Ca(OH)₂. In contrast, the dewatering performance of WAS, could be improved by adding calcium hydroxide instead of sodium hydroxide (Su et al., 2013). The lower COD solubilization and a better dewaterability obtained with calcium hydroxide could be caused by the calcium bridging (Wang et al., 2012; R. Wang et al., 2016b). Guan et al. (2012) observed that Ca²⁺ interacted with proteins, phenols and carboxylic and hydroxyl functional groups in the sludge flocs. This leads to re-flocculation of dissolved organic polymers, and thus to a decrease in soluble COD (Jin et al., 2009).

Effects on WAS

Floc and cell disruption

It has been observed that the average particle size of the sludge during alkaline pre-treatment decreases (Doğan and Sanin, 2009; Kim et al., 2003; Xiao et al., 2015). The high pH values cause floc break-up, which relates to an increase in hydrolysis rate and worsened dewaterability of the digestate. With regard to cell disruption, in the pH range of 8.0-12.5, Xiao et al. (2015) observed that most of the damage to the cell wall and cell membrane occurred at pH 10.00–12.50 and pH 9.00–12.50, respectively. Similarly, in a pure culture of *FloVabacterium aquatile* (a representative bacteria of WAS), disruption was observed to occur up to a pH of 12.30 (Erdirinler and Vesilind, 2000), while Doğan and Sanin (2009) determined that pH 11 did not significantly cause cell damage compared to pH 12-12.5. Literature data suggest that extensive cell disruption is achieved at pH around 10-12.

Carbohydrates, proteins and humic substances

The solubilization of organic matter has been reported to be low at $\text{pH} < 10$ and was found to increase with increasing pH (Chang et al., 2011; Valo et al., 2004; Xiao et al., 2015). However, a pH value of 13, only lead to a marginal increase in solubilization of organic matter as compared to pH 12 (Chang et al., 2011). During alkaline pre-treatment, proteins are solubilized (Brown and Lester, 1980; Doğan and Sanin, 2009; Shao et al., 2012), and partly degraded (Wang et al., 2012). In contrast to proteins, at pH 10 and with application of $\text{Ca}(\text{OH})_2$, the hydrolysis of carbohydrates was not significantly affected (Su et al., 2013). Despite humic acids being stable compounds, considerable changes are observed in high pH solutions. For instance, their solubility increases in direct proportion to pH (Tipton et al., 1992).

Hydrolysis and biodegradation

After neutralization of the pre-treated sample, Shao et al. (2012) observed that the hydrolysis rate increased applying pH 10, but it was reduced using pH values of 11 and 12. The increase in hydrolysis rate could be explained by the solubilization of organic matter and the observed particle size reduction of WAS. The reduction in particle size can be ascribed to the formation of refractory products under highly alkaline conditions. Table 2.10 lists results from alkaline pre-treatments at room temperature. The majority of the reported studies had been performed with NaOH dosing. From intra-study comparison, it was concluded that different pH values result in different biogas yields. For example, after pre-treatment and neutralization, Shao et al. (2012) observed that biogas production was the highest when applying pH 10, and decreased in the following order: pH 9, pH 8, pH 11. In that study, the biogas production at pH 12 was 18.1% lower than the control. Similarly, Valo et al. (2004) found that the biogas production using pH 12 (without post-neutralization but using a substrate:inoculum ratio of 1:10 v/v) was the same as the control. In general, pH values lower than 12 increased the biodegradation only marginally, i.e., by about 5% in absolute terms (Table 2.10, entries a to e). In contrast, above pH 12, the effects on biodegradation or biogas production become variable and contradictory (entries f to k), which could be caused by:

- the formation of refractory compounds. Despite the observation that biodegradation remains the same or is even reduced at pH 12 (Penaud et al., 1999; Valo et al., 2004), an observed continuous increase in COD solubilization (Chang et al., 2011; Uma Rani et al., 2012; Valo et al., 2004), suggests formation of soluble but refractory compounds. A similar trend is observed for thermal hydrolysis.
- inhibition during anaerobic digestion caused by chemical reagents. Sodium concentrations of 3 g Na^+ /L or higher can inhibit digestion (Feijoo et al., 1995; D.-H. Kim et al., 2013). On the other hand, Penaud et al. (1999), found that just the presence of hydroxyl ions decreased biodegradation at a dosage of 327 mg NaOH/gTS or 5.7 g Na^+ /L (the presence of a buffer during the digestion was not clear). Moreover, after adaptation to high salinity conditions, sludge methanogenesis may proceed well, even under marine conditions (Zhang et al., 2013).

A final consideration regarding biodegradation is the adjustment of pH before anaerobic digestion. Pre-treatment of sludge at pH 12 in a semi-continuous digestion, without pH adjustment after pre-treatment, increased biodegradation by 13% (Table 2.10, entry k), resulting in a pH of 7.84 in the digester (Lin et al., 1997). Provided that ammonium toxicity is more likely to occur at higher pH (Chen et al., 2008; Hansen et al., 1998), the previous result suggests that anaerobic digestion can cope with high

pH values, thus avoiding or at least reducing the need of a neutralization step. Acclimation is also a possibility, as reviewed by Chen et al. (2008).

Table 2.10 Effects on the biodegradation of WAS after alkaline pre-treatment.

Entry	Temperature, °C	Reagent	pH	Required reagent to reach pH, mg reagent/gTSludge	Change in biodegradation (vs. control)	Change in biogas production (vs. control)	pH neutralization	Reference
pH from 8 to 11.6								
a	25	NaOH	8.07	76	↑ 13% (from 28 to 41)		No neutralization	(Lin et al., 1997)
b	“Ambient”	NaOH	10	Not disclosed		↑15.4%	Down to pH 6.8	(Shao et al., 2012)
c	20	NaOH	10.10	40	↑ 4% (from 30 to 34)		Down to pH 8.5	(Ruffino et al., 2016)
d	20	NaOH	11.60	80	↑ 5% (from 26 to 31)		Down to pH 7.5	(Ruffino et al., 2016)
e	20	NaOH	11.60	80	↑ 4% (from 26 to 30)		Down to pH 8.5	(Ruffino et al., 2016)
pH≥12.00								
f	“Ambient”	NaOH	≈12.0	150.3	↑ 35% (from ≈17 to ≈52)		Not disclosed	(Penaud et al., 1999)
g	“Ambient”	NaOH	12	Not disclosed		↓18.1%	Down to pH 6.8	(Shao et al., 2012)
h	“Room”	KOH	12	213		=	Not disclosed	(Valo et al., 2004)
i	“Ambient”	NaOH	12	184	↑ 3% (from 26 to 29)		Not disclosed	(Kim et al., 2003)
j	“Ambient”	NaOH	≈12.2	852.9	↓12% (from ≈17 to ≈5)		Not disclosed	(Penaud et al., 1999)
k	25	NaOH	12.26	128	↑ 13% (from 28 to 41)		No neutralization	(Lin et al., 1997)

Limiting factors, advantages and perspectives

A clear disadvantage of alkaline pre-treatment is the cost of chemical reagents and the addition of inorganics to the WAS. The production of chemicals requires energy (Folke et al., 1996; Kent, 2013), and therefore the energy feasibility of the process should be considered for alkali addition. Application of alkaline pre-treatment increases biodegradation in a similar degree as low-temperature thermal pre-treatment (see Table 2.2 and Table 2.10), although the energy input for alkaline pre-treatments seems lower according to Table S2-1, even when the required energy for the manufacture of the alkali is considered.

2.2.8.2 Acidic pre-treatment

Process description and mode of action

During acid pre-treatment, pH ranges between 1 to 5.5 and chemical reagents such as HCl, H₂SO₄, H₃PO₄ and HNO₂ are commonly used. In order to form HNO₂ (the protonated form of nitrite), a nitrite solution is added to reach a concentration of around 1 g NO₂⁻/L, while the pH is lowered to around 5.5. The resulting concentration of HNO₂ can be calculated via methods shown by prior research (Wang et al., 2013; T. Zhang et al., 2015). In contrast to other acids, HNO₂ does not seem to completely act under a pH-related mechanism (Zahedi et al., 2016). Lipid peroxidation (Horton and Philips, 1973) and the disruption of the cell envelope (Pijuan et al., 2012; Wu et al., 2018), are also effects of HNO₂. For acid pre-treatment, the protonated states of the functional groups in EPS result in more dense and compact

structures at a lower pH because of hydrophobicity and intermolecular hydrogen bonds (Wang et al., 2012). At low pH, hydrogen ions react with the ionized carboxyl groups to form undissociated acid groups and therefore carboxylic acid groups are present in their un-ionized form. Thus, ionization of the acid groups is suppressed, causing aggregation. The highest flocculation efficiency is achieved near the isoelectric point (Wang et al., 2012). Regarding proteins, their isoelectric point differs for each one of them, and depends upon the ratio of free ionized carboxyl groups to free ionized amino groups (Vaclavik and Christian, 2008).

Effects on WAS

Floc and cell disruption

Below the pH value of the isoelectric point of the sludge, a positive charge is present within the EPS, which prevents aggregation (Liao et al., 2002; Wang et al., 2012) and causes a reduction in particle size. For instance, at a pH 0.98 with application of H₂SO₄, Guo et al. (2014) observed that the average particle size was reduced from 159.62 to 97.18 μm. Similarly to alkaline pre-treatment, saponification of the cell wall could also occur under acidic pH values (Charton, 1975). Under acidic conditions, about 15% of the bacterial cells suffered from damaged cell membranes, compared to about 10% for the control (Guo et al., 2014). In contrast, when HNO₂ was used, even at pH 6, viable cells accounted for 20% in contrast to 80% for the control (Pijuan et al., 2012). A significant reduction in viable cells was also found by Wu et al. (2018), suggesting the biocidal effect of HNO₂.

Carbohydrates, proteins and humic substances

Even though mild acid pre-treatment at pH 4 and 5 is able to solubilize COD, alkaline pre-treatment is reported to be more effective for releasing COD (Chen et al., 2007; Guo et al., 2014). Acid pre-treatment with HCl or H₃PO₄ is effective for COD solubilization but, only at pH values of 1-2 (Devlin et al., 2011; Sahinkaya, 2015), with a 4-fold and a 6-fold increase in solubilization of carbohydrates and proteins, respectively (Devlin et al., 2011). On the other hand, application of HNO₂ at pH 5.5 even led to deamination (T. Zhang et al., 2015). Humic acids are expected to precipitate under acidic conditions (pH < 2), while fulvic acids remain in solution (Ghabbour and Davies, 2001). Humic and fulvic acids can form complexes with proteins, which are difficult to degrade, but lowering the pH can cause the release of proteins from these complexes, increasing bio-availability (Zahedifar et al., 2002). However, if the pH is adjusted before digestion, humic acid-protein complexes will be re-established. HNO₂ was also able to solubilize carbohydrates and proteins (Li et al., 2016).

Hydrolysis and biodegradation

Application of acid can lead to an increase in bioconversion rate (Devlin et al., 2011; Wang et al., 2014) as well as biodegradation (Devlin et al., 2011). Biodegradation increased substantially when the applied pH values reached 1 and 2 (Table 2.11, entries a and b), but not at pH values of 3 to 6 (Devlin et al., 2011), when using different doses of HCl. The application of HNO₂ (Table 2.11, entries c and d), resulted in similar increases in biodegradation compared to hydrochloric acid (HCl), although it may inhibit methanogens (Li et al., 2016).

Table 2.11 Effects on the biodegradation of WAS after acid pre-treatment.

Entry	Temperature, °C	Reagent	pH	Required reagent to	Change in biodegradation (vs. control)	pH neutralization	Reference
-------	-----------------	---------	----	---------------------	--	-------------------	-----------

				reach pH, mg reagent/gTS _{sludge}			
a	Not disclosed	HCl	1.00	369	↑12% from 41 to 53%	Up tp pH 6.8	(Devlin et al., 2011)
b	Not disclosed	HCl	2.00	184	↑6% from 41 to 47%	Up tp pH 6.8	(Devlin et al., 2011)
c	25	NO ₂ (then formed HNO ₃)	5.5 (controlled)	19.3	↑9% from 36 to 45%	Not disclosed	(Wang et al., 2013)
d	25	NO ₂ (then formed HNO ₃)	5.5 (controlled)	18.2	↑20% from 33 to 53%	Not disclosed	(T. Zhang et al., 2015)

Limiting factors, advantages and perspectives

Acid pre-treatment requires pH levels of pH≤2 to deliver positive results (Devlin et al., 2011; Sahinkaya, 2015). Such a low pH value requires considerable amounts of both acid and alkaline solutions to adjust the pH. Also, the reactors should be made of a material able to withstand these low pH values, thus increasing capital investment. To our knowledge no studies have been conducted on the effect of pH readjustment after acid pre-treatment. However, it is widely known that methanogenic organisms are easily inhibited at low pH, inferring that neutralization is mandatory for acid pre-treatment. Regarding the energy balance, added chemicals have an energy value and therefore acid pre-treatment with HCl results in a similar energy balance and sludge biodegradation compared to alkaline pre-treatment (Table S2-1), although a lower solubilization during pre-treatment and a lower VS reduction during digestion is reached. The use of HNO₂ for pre-treatment seems to provide comparable biodegradation increases as with the use of HCl, but at milder pH values (e.g., 5.5). Furthermore, rejected water produced after digestate dewatering could be used as a precursor for HNO₂ (Wang et al. 2013). As a consequence, HNO₂ could be a sustainable, yet effective solution for WAS pre-treatment. However, additional research is required to unveil the underlying mechanisms of pre-treatment with HNO₂ and to confirm the observed results.

2.2.8.3 Advanced oxidation processes (AOPs)

Process description and mode of action

Advanced oxidation relies on the oxidation abilities of hydroxyl radicals, a highly reactive and short-living species. Its reactivity is due to its standard electrode potential of +2.3 V (Farr and Kogoma, 1991). As a consequence, hydroxyl radicals react with (almost) every organic substance present in WAS without any selective mechanism. Advanced oxidation can even lead to the complete mineralization of WAS (Xu et al., 2010). The formation of radicals originates from processes such as ozonation and Fenton chemistry and from compounds such as hydroperoxides (i.e., hydrogen peroxide). These three oxidative agents will be discussed below.

Ozone (O₃) is an unstable molecule produced by the electrical stimulation of oxygen. Once produced, it is transferred from the gaseous into the liquid phase, where it decomposes into radicals and reacts with WAS (Bougrier et al., 2006). Ozone breaks high molecular weight organic compounds into lower weight products, such as carboxylic acids, hydrophilic acids, carbohydrates, amino acids and VFA (Bougrier et al., 2007a, 2006; Salsabil et al., 2010). The formation of acid compounds correlates with a typical decrease in the pH of about 1 or even 2 units after ozonation (Bougrier et al., 2006; Chu et al., 2008; Tian et al., 2015b). Yang et al. (2013) observed that ozone first reacted with the soluble fraction of the sludge and then oxidized the particulate fraction. However as more intracellular substances are released, the soluble fraction can have a scavenging effect on the ozone (Cesbron et al., 2003). In line

with this finding, Bougrier et al. (2006) observed that the biodegradation of the particulate fraction was barely modified.

The Fenton reaction leads to the formation of hydroxyl radicals through the reduction of hydrogen peroxide by reduced transition metals (typically iron), working as catalysts (Kohanski et al., 2007). The rate and extent of the Fenton reactions are dependent on iron and hydrogen peroxide concentration, as well as on the pH of the solution (Erden and Filibeli, 2011; Sahinkaya, 2015). At pH values of 4 and higher, ferric ion precipitates and loses its catalytic activity (W. Zhang et al., 2015a). For WAS pre-treatment mainly pH values of 2 or 3 have been applied (Bao et al., 2015; Gong et al., 2015). Three features make this technique appealing: a) hydroxyl radical formation; b) low pH similar to acid pre-treatment; and c) improved dewaterability of the digestate due to coagulation by iron addition (E. Neyens and Baeyens, 2003). However, the addition of iron salts and other chemical reagents to adjust the pH leads to increased costs and energy usage.

With the aim of reducing resource consumption, milder pre-treatments have been studied. The standalone application of H₂O₂ oxidizes organic compounds to CO₂ and water (Eskicioglu et al., 2008) without leaving detrimental by-products nor disturbing sludge pH (Jung et al., 2014), in contrast to ozonation.

Effects on WAS

Floc and cell disruption

Oxidizing agents reduce the particle size of WAS (Demir and Filibeli, 2012). However, the reduction ceases at 100 to 160 mg O₃/g TS (Bougrier et al., 2006). Oxidizing agents also disrupt cell walls, as up to 50% of microorganisms were observed to be deactivated at an ozone dose of 20 mg O₃/g TSS (Chu et al., 2008).

Carbohydrates, proteins and humic substances

An important effect during AOPs is the mineralization process. It has the advantage of reducing the volume of solids, but the drawback of converting organic carbon to CO₂ (Délérís et al., 2000), resulting in less organic matter available for biogas production. Mineralization (measured by the reduction in COD) seems to increase with increased doses of oxidizing agent. A low dose of oxidizing agent (70 mg O₃/g TS) was reported to result in minimal mineralization (Braguglia et al., 2012), while high doses >200 mg O₃/g TS resulted in extensive mineralization (Ahn et al., 2002; Délérís et al., 2000). Sugars and humic acids showed the highest reduction in concentration during oxidative pre-treatment (Eskicioglu et al., 2008).

The reaction between radicals and proteins could lead to deactivation and degradation of enzymes (Farr and Kogoma, 1991). Silvestre et al. (2015) hypothesized that the change in the secondary and tertiary structure of the amino-acids could explain the observed higher biogas potential. On the other hand, the reaction between hydroxyl radicals and humic substances could increase the soluble COD concentration without the formation of biodegradable organic substrates (Goldstone et al., 2002).

Hydrolysis rate and biodegradation

As indicated above, pre-treatments with AOPs reduce the mean particle size of WAS at low doses of oxidizing agents, which results in an increased hydrolysis rate. However, high doses of oxidizing agents were observed to lead to a decrease in hydrolysis rate (Appels et al., 2011; Silvestre et al., 2015; Tian et

al., 2015b; T. Zhang et al., 2015; Zhou et al., 2015). Liu et al. (2015) showed an inhibitory effect of AOPs on anaerobic digestion.

Increasing the doses of an oxidizing agent, leads to an increase in sludge biodegradation, however, exceeding certain doses could lead to a decrease in biodegradation, sometimes even lower than the control (Braguglia et al., 2012; Silvestre et al., 2015; T. Zhang et al., 2015). The dose at which the maximum biodegradation could be achieved, differs among the various studies (Table 2.12), and is probably because of the variability in the composition of WAS that was used. The presented data, suggests that ozonation performs best around 150 mg O₃/gTS, although lower doses could be sufficient for improvement over control (Table 2.12 entries d to f). The lower biogas production at higher doses could be due to a) inhibitory conditions; b) mineralization of organic biodegradable compounds; and c) formation of refractory compounds (Bougrier et al., 2006; Liu et al., 2015; Silvestre et al., 2015).

Table 2.12 Effects on the biodegradation of WAS after AOPs pre-treatments.

Entry	Type of AOP	Oxidant dose, mg reagent/gTS _{sludge}	Oxidant dose, mmol reagent/gTS _{sludge}	Change in biodegradation (vs. control)	Change in biogas production (vs. control)	Reference
a	Ozone	15	0.31		↑ 30%	(Bougrier et al., 2007a)
b	Ozone	40	0.83		↑ 4.7%	(Silvestre et al., 2015)
c	Ozone	50	1.04		↓ 5.8%	(Braguglia et al., 2012)
d	Ozone	59	1.23		↑ 21.6%	(Silvestre et al., 2015)
e	Ozone	60	1.25		↑ 58%	(Bougrier et al., 2007a)
f	Ozone	70	1.46		↑ 16.7%	(Braguglia et al., 2012)
g	Ozone	77	1.60		↓ 13.8%	(Silvestre et al., 2015)
h	Ozone	93	1.94		↓ 5.6%	(Silvestre et al., 2015)
i	Ozone	100	2.08		↑ 11%	(Bougrier et al., 2006)
j	Ozone	150	3.13		↑ 140%	(Bougrier et al., 2007a)
k	Ozone	160	3.33		↑ 23%	(Bougrier et al., 2006)
l	Ozone	180	3.75		↑ 91%	(Bougrier et al., 2007a)
m	H ₂ O ₂	10	0.29	↑ 4% (from 33 to 37)		(T. Zhang et al., 2015)
n	H ₂ O ₂	30	0.88	↑ 8% (from 33 to 41)		(T. Zhang et al., 2015)
o	H ₂ O ₂	50	1.47		= (as CH ₄)	(Zhou et al., 2015)
p	H ₂ O ₂	50	1.47	↑ 7% (from 33 to 40)		(T. Zhang et al., 2015)
q	H ₂ O ₂	80	2.35	↑ 6% (from 33 to 39)		(T. Zhang et al., 2015)
r	Fenton	pH 3 Fe ²⁺ =4 mg/gTS H ₂ O ₂ = 40 mg/gTS	1.18	↑ 12% (from 20 to 32)		(Sahinkaya, 2015)
s	Fenton	pH 2 Fe ²⁺ =7 mg/gTS H ₂ O ₂ = 50 mg/gTS	1.47	↑ 6% (from 48 to 54)		(Zhou et al., 2015)
t	Fenton	pH 3 Fe ²⁺ =4 mg/gTS H ₂ O ₂ = 60 mg/gTS	1.76		↑ 19.3% (as CH ₄)	(Erden and Filibeli, 2011)

At similar hydrogen peroxide concentrations, the Fenton pre-treatment outcomes are comparable to addition of H₂O₂ (Table 2.12, entries r to t and entries m to q respectively, Figure 2.2). This is unexpected because the low pH of the Fenton reaction should favor the formation of more radicals, thus increasing organic matter degradation. The acidic environment should also increase the WAS biodegradation.

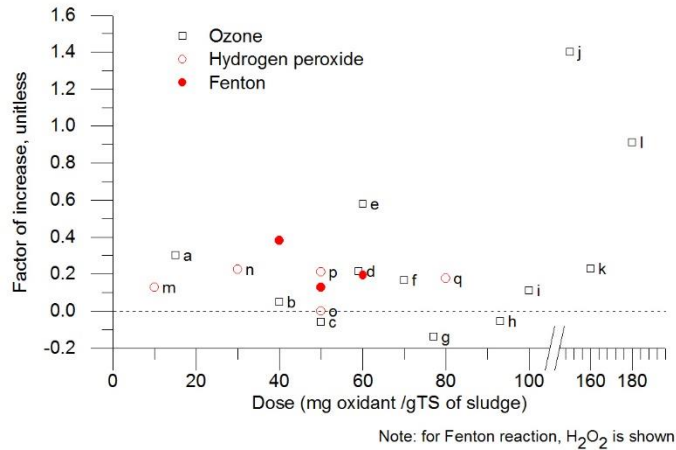

Figure 2.2 Effect of oxidant doses in the biogas production. Letters refer to entries in Table 2.11. This graph is presented in Supplementary information as Figure S2-1, using mmol of oxidant/gTS in the x-axis.

Limiting factors, advantages and perspectives

From an energy consumption viewpoint, 50% of the energy demand during ozonation is used for the production of pure oxygen as an input element (Müller et al., 2004). As a consequence, ozonation is scarcely applied to sludge because of its high electrical energy consumption (Xu et al., 2010). The Fenton reaction requires not only H₂O₂ but also other reagents to acidify and neutralize the pH of the WAS. Fenton-treated sludge contains iron-hydroxide complexes, which could limit the usage alternatives of the digested sludge in the final disposal stage (Sahinkaya, 2015). On the other hand, the sole addition of hydrogen peroxide involves only the energy required for producing the reagents. Figure 2 shows that the three AOPs techniques presented seem to deliver similar biogas or methane increases up to an oxidizing dose of 100 mg/g TS. Then, if the improvements in biogas production are comparable between AOPs, the best alternative seems to be H₂O₂ addition, according to the energy balance (Table S2-1). H₂O₂ addition can be considered the technique with the lowest energy demand. A niche application of AOPs could be the oxidation of refractory substances (e.g. mineralization of humic substances), or for the treatment of digested sludge, as it contains a higher fraction of refractory substances compared to WAS (Kobayashi et al., 2009).

2.2.9 Biological pre-treatment

Process description and mode of action

Bacteria and archaea break down organic matter with the help of enzymes. Due to their catalytic nature, enzymes hydrolyze complex molecules at milder pH values, and temperatures, and without the production of hazardous waste, compared to chemical or physical pre-treatment methods (Parawira, 2012). The products of hydrolysis are available for further conversion. Enzymes are located both inside and outside the cells. The latter are further divided into cell surface bound (ectoenzymes) and free form (exoenzymes). Exoenzymes are located in water and/or adsorbed within the extracellular polymeric substances of the sludge matrix (Burgess and Pletschke, 2008). However, in contrast to ectoenzymes, exoenzymes do not show relevant lytic activity (Burgess and Pletschke, 2008). In order to increase the lytic potential, intracellular enzymes should be released by disrupting the cell membrane (Kavitha et al., 2014). However, free enzymes are prone to self-degradation before sludge hydrolysis starts (Müller, 2001). In order to overcome self-degradation, the enzymes must be immobilized onto solid media such

as substrate, extracellular polymeric substances and flocs, which make them more stable (Burgess and Pletschke, 2008; Matsumoto and Ohashi, 2003) and usable as pre-treatment. On the other hand, immobilization has been postulated to decrease the efficiency of the pre-treatment (Kavitha et al., 2014; Parawira, 2012).

There are two ways to do enzymatic pre-treatment: active addition of enzymatic solutions, which according to Parmar et al. (2001) makes the pre-treatment economically infeasible; or by bioaugmentation. The latter method fosters the endogenous enzyme (or enzyme-producing microorganisms) (S. Yu et al., 2013). Recently, surfactants that can be biologically produced by many different microorganisms, such as rhamnolipids, have been used for pre-treatment (He et al., 2016; Kavitha et al., 2016, 2014; Zhou et al., 2013). According to Zhou et al. (2013), rhamnolipids increase the solubility of compounds and provoke the EPS to detach from the attached cell surface. Also, they observed an increase in hydrolytic enzyme activity, and postulated that rhamnolipids hindered the immobilization of naturally present enzymes in the sludge or liberated the trapped enzymes within the floc matrix.

Effects on WAS

Floc and cell disruption

By testing an amylase-producing-stain, a protease-producing stain and a blend of both, S. Yu et al. (2013) found that the mean particle size decreased from 87.4 μm (control) to 74.1, 85.4, and 65.8 μm for amylase, protease and blended pre-treated samples, respectively. The effect of protease was negligible in particle size reduction. They hypothesized that the reduction in particle size was not caused by the direct conversion from solid to soluble particles, but because enzymes acted against EPS that have a role in sludge aggregation. In contrast, with a protease treatment at a dosage of 100 mg/L the average particle size reduced from 128 to 81 μm (Yi et al., 2014). Operation at sub-optimal levels of enzyme may explain the conflicting results.

Endogenous enzymes did not cause significant lysis, indicating that the observed effects related to increasing soluble organic matter mainly derived from EPS, whereas enzymatic treatment on sludge integrity was limited (S. Yu et al., 2013). Sesay et al. (2006) measured viable cell counts after application of α -amylase, cellulase and proteinase, and observed an insignificant amount of cell lysis. Finally, based on scanning electron microscopic imaging and the increase in DNA, Yi et al. (2014) inferred that protease treatment did not result in bacterial cells being destroyed.

Carbohydrates, proteins and humic substances

After protease pre-treatment, only a low amount (4%) of proteins were solubilized, while the amount of soluble humic substances increased from 361 to 1108 mg/L (Yi et al., 2014) probably because of the destruction of protein-humic acid assemblies.

Hydrolysis rate and biodegradation

In some cases, the hydrolysis rate of enzymatically pre-treated WAS increased with the sole addition of a protease (Ushani et al., 2016), while in other cases a blend of amylase and protease was required to increase the hydrolysis rate (S. Yu et al., 2013). The results concerning WAS biodegradation are conflicting. In some cases, enzymatic pre-treatment (with amylase only, and amylase with protease) led

to an enhancement of the specific biogas production (S. Yu et al., 2013). While in other cases the biodegradation did not increase using these enzymes (Bayr et al., 2013) nor using solely proteases (S. Yu et al., 2013). The added enzymes may increase the amount of biogas produced, due to their own digestion, and this could be a cause for the contradictory results observed. Unfortunately, no mass balances were found to corroborate this hypothesis. Finally, rhamnolipids does not seem to be a suitable pre-treatment for increasing methane production, as the activity of methanogens is inhibited (Zhou et al., 2013). Nonetheless, acidifiers are not impaired during this process, making it a suitable method for VFA production from WAS.

Limiting factors, advantages and perspectives

It seems that the sole addition of proteases does not result in significant solubilization (Yi et al., 2014) nor biodegradation increase (S. Yu et al., 2013), while amylase seems to increase both parameters. As different enzymes have varying pH and temperature optima and tolerance ranges, it is possible that the enzyme had to work at suboptimal levels (Burgess and Pletschke, 2008), resulting in the spread of results observed during enzymatic pre-treatment. Even though information is missing about the optimum conditions required for the use of an enzyme blend on a complex substrate such as WAS, the costs of even low-purity enzymes is still prohibitive (Parawira, 2012). Even though, bioaugmentation could be a strategy for producing the required enzymes, this also has its drawbacks. For instance, culturing the proper microorganisms demands pH control and substrate addition.

2.3 Overall discussion

A brief summary of the effects of different pre-treatments on the main components of WAS is presented in Table 2.13. In Table 2.14 a qualitative assessment of the effects of different pre-treatments on the sludge characteristics, regarding degradability and economic feasibility, is shown.

From Table 2.14 it is clear that most of the pre-treatments increase the hydrolysis rate. The improvement is particularly high for thermal and ultrasonic pre-treatments. Since hydrolysis is regarded as the rate-limiting step in WAS treatment, an increased hydrolysis rate is indicative for a potential increased solids loading rate to existing sludge digesters without retrofitting the sewage treatment plant. However, in some cases chemical and microwave pre-treatments have shown conflicting results regarding the resulting hydrolysis rate. Likely, this can be ascribed to the excessive utilization of chemicals or energy inputs, which can potentially create refractory, inhibitory or even toxic products that cannot be degraded during batch tests. Thermal hydrolysis, TPAD and microwave pre-treatments all substantially increase the sludge biodegradation. In this respect, the effect of low-temperature pre-treatment on biodegradation remains somewhat uncertain. The latter could be related to the applied temperature increase rate, which has also been considered relevant for other thermal pre-treatments such as microwave and freeze and thaw (Hosseini Koupaie et al., 2017; Montusiewicz et al., 2010). Montusiewicz et al. (2010) considered the similarity of the freezing and thermal treatment effects as well, in the sense that the temperature-change rate could have an impact on the outcome of the process. Nonetheless, further research regarding the specific mechanisms of low-temperature pre-treatment is still missing.

As shown in supplementary information (Table S2-2), the minimum amount of VS required to achieve a neutral energy balance is around 30 gVS/L for low-temperature thermal pre-treatment and about 160 gVS/L for thermal pre-treatment above 100°C (thermal hydrolysis). In addition to the higher

temperature, other characteristics of thermal hydrolysis that explain the higher minimum solids concentration are: i) the low potentials for the recovery of high-quality heat from the combined heat power plant (CHP) to be used to produce steam, and ii) a lower efficiency of heat exchange to pre-heat the incoming sludge. In order to reduce the required solids concentration, in practice, non-treated primary sludge is blended with treated WAS before digestion. This step increases methane production, and allows a lower solids concentration to be used without affecting the overall energy balance. Another option is the direct generation of steam by the biogas, instead of burning the biogas in a CHP for electricity production.

Thermal hydrolysis, TPAD, alkaline, microwave, and mechanical pre-treatments are all methods to substantially increase VS removal and thus reduce the volume of the digestate to be disposed. Microwave, ultrasonic and mechanical pre-treatment techniques all have a high electricity requirement. The pre-treatment itself could lead to an increase in biodegradation, but the energy balance regarding electricity production of these pre-treatments becomes less positive or even negative. For instance, according to the supplementary information (Table S2-3), absolute biodegradation, even exceeding the theoretical limit of 100%, is required to achieve a neutral electricity-balance in some cases, such as for ultrasonic pre-treatment. In the latter case, increasing the solids concentration is not an option as it reduces the efficiency of the ultrasonic pre-treatment. For microwave pre-treatment, the energy consumption is even higher: a hypothetical biodegradation of 100% after pre-treatment would only cover 50% of the energy requirement (Supplementary information, Table S2-3). For alkaline pre-treatments, the costs of chemical reagents remain as a principal drawback. The freeze and thaw pre-treatment requires a large surface area and naturally occurring freezing temperatures. This pre-treatment is only applicable in a few regions because of these naturally limiting factors. If freezing temperatures are to be achieved artificially, the electrical consumption would make the energy balance negative.

Regarding dewaterability, low-temperature, ultrasonic and alkaline pre-treatments, seem to reduce the dewatering ability of the digestate. In contrast, TPAD, thermal hydrolysis, acid, AOPs and microwave pre-treatments seem to improve this parameter. Floc size is known to have substantial impact on sludge dewaterability (Gao, 2011). However, the reduction in particle size after the pre-treatment does not necessarily reduce the dewaterability of the digestate, as observed for acid, AOPs and mechanical techniques. Finally, with increasing attention on VFA production instead of methane, alkaline pre-treatment looks particularly attractive, since alkali dosing is often required to promote VFA formation.

The selection of an optimal pre-treatment method depends on (natural) local conditions, but also on economics and regulations. Firstly, full-scale disintegration technologies are feasible only if the sludge disposal costs are high (Müller et al., 2004). Secondly, investment and operational costs must be considered (Table 2.14). In general, chemical and enzymatic pre-treatments are not favored because of the dosage of reagents, whereas thermal hydrolysis seems ideal when pasteurization or sterilization of sludge is required by regulations prior to land disposal or agricultural reuse. Thermal hydrolysis also results in a high level of solids reduction, although investment and operational costs are high as well. It should be realized that due to fluctuating energy prices, the focus on increasing methane production is not always economically appealing. In fact, solids reduction is more relevant than methane production for countries such as the Netherlands, where costs for disposal are high, since incineration is the sole outlet. VS reduction as well as increased dewaterability is not only relevant for disposal costs, but also

lower required polyelectrolyte dosing could increase the economic feasibility of the pre-treatment method.

Life cycle assessment (LCA) could shed light on the overall cost effectiveness of each technique; however, studies performing LCA on sludge pre-treatment are missing in literature. Pre-treatments based on milder temperature and pH conditions, seem to represent a good opportunity to develop less resource-demanding pre-treatments. Low-temperature, TPAD and hydrodynamic cavitation are techniques that have shown interesting results without the use of harsh conditions and can be considered cost effective pre-treatment techniques.

Despite several studies comparing different pre-treatment techniques, direct comparisons are often unfair. The operational parameters of some techniques are occasionally assayed far from their optimum values, with disproportionate energy inputs or are set at values that could produce recalcitrant or even toxic by-products, resulting in reduced or low performance. It is very important to consider these factors when doing comparisons between the different pre-treatments. On the other hand, considerable research has also been done to assess the synergetic effects of the combination of several different pre-treatments. For instance, Doğan and Sanin (2009) observed that the deteriorated dewaterability caused by alkaline pre-treatment can be improved by the incorporation of microwave irradiation and the protein release can be higher compared to the summation of the release by each method individually. Synergies have also been observed by Kim et al. (2010) and Joo et al. (2015). However, the combination of two pre-treatment techniques does not always result in a direct additive effect (Eskicioglu et al., 2008; Sahinkaya, 2015; Yeneneh et al., 2013), but may lead to an increase in the consumption of energy and/or chemical reagents.

Regarding research gaps, it is clear that pre-treatments such as low-temperature or TPAD result in low electrical energy consumption compared to the more sophisticated methods, such as ultrasonic, microwave and freeze and thaw (if artificial freezing would be used). The exact working mechanisms of these pre-treatments are missing. Finally, information about the production of recalcitrant or inhibitory by-products, not only during thermal hydrolysis, but also during chemical pre-treatments, is still missing. These by-products could become problematic during anaerobic digestion of the pre-treated sludge and/or the subsequent side-stream treatment of the concentrated sludge reject water, or even for the treatment of the recycled reject water in the mainstream water line of the wastewater treatment plant.

Finally, the use of COD solubilization for judging the efficiency of pre-treatments must be discouraged. Until now, the sludge biodegradation assays or BMP tests remain as the only method to accurately assess the performance of WAS pre-treatments to maximize methane production. Proper inter-study comparisons between pre-treatments are only possible if hydrolysis rate, biodegradation and/or BMP values, and COD balances of the samples are reported. Also, additional efforts should be taken to characterize the sludge into its specific components and not merely into VS and/or COD. The use of thickened sludge in performing research on pre-treatment methods must also be promoted to account for real-world conditions. For calculations regarding the economic viability of a pre-treatment the amount of energy consumed (heat and/or electrical) by the equipment, energy losses, energy actually delivered to the sample, and in the case of chemical pre-treatments, the actual amount of reagent used, should be mentioned. Valuable add-ons are the change in dewaterability and VS reduction. All these features would increase the reproducibility and comparability of results, despite the varying composition of WAS.

2.4 Conclusion

Based on the current knowledge, the best alternative for a pre-treatment method is defined based on the objectives of the treatment (the listed pre-treatment techniques are not specifically ordered):

- Increasing methane production: thermal pre-treatment $>100^{\circ}\text{C}$, TPAD and microwave
- Increasing volatile solids removal: thermal pre-treatment $>100^{\circ}\text{C}$, TPAD and alkaline
- Improving the dewaterability of digestate: thermal pre-treatment $>100^{\circ}\text{C}$, TPAD and microwave
- Lowering energy consumption: TPAD and thermal pre-treatment $<100^{\circ}\text{C}$
- Lowering operating and capital costs: TPAD and thermal pre-treatment $<100^{\circ}\text{C}$

Microwave, however, uses electrical energy and is thus economically not advantageous. Therefore, overall, low- and high-temperature pre-treatment and TPAD are the most promising pre-treatment methods.

Finally, to thoroughly understand the different mechanisms of different pre-treatment methods, more attention should be paid to the conversion of, and structural change in, the different (complex) components of waste activated sludge during their application.

Table 2.13 Effects of pre-treatments on some WAS components.

Pre-treatment technique	Bacterial biomass	Protein	Carbohydrate	Humic substances	Effects on other components or in combinations
Thermal <100°C	Cell wall starts rupturing at ≥50°C	Denaturation occurs at around 75°C	Only solubilization	Unaffected. Solubilization up to around 75°C and they become flexible at 70-80°C (T _{glass})	Proteins and humic acids form assemblies, protecting the former from biological degradation Proteins and carbohydrates: amino carbonyl reaction occurs even at 60°C, and rate increasing in proportion to application time
Temperature phased anaerobic digestion (TPAD)	Same as thermal <100°C pre-treatment	Same as thermal <100°C pre-treatment	Same as thermal <100°C pre-treatment	Same as thermal <100°C pre-treatment	Same as thermal <100°C pre-treatment
Thermal >100°C	Extensive cell wall and membrane disruption	Extensive denaturation Protein degradation starting at >170-190°C	Theory: caramelization at 170°C (formation of aldehydes and ketones) Practice: solubilization and low degree of degradation into mono or dimeric sugars at 220°C	≥110°C gradual decomposition of humic acids, resulting in the production of CO ₂ and CO Dissociation at 150-180°C	Maillard reaction proceeds faster as compared to thermal pre-treatment below 100°C
Microwave	Cell lysis due to thermal effects	Same as thermal pre-treatment <100°C and thermal hydrolysis, depending on temperature			
Freeze and thaw	Limited cell lysis probably because of cryoprotectant components (e.g. glycerol)	Enzymes still working Protein denaturation and formation of aggregates			
Ultrasonic (temperature <40°C)	Extensive deflocculation Limited cell disruption	Solubilization, probably caused by deflocculation			
Hydrodynamic cavitation, milling and homogenization	Limited cell lysis due to grinding or cavitation	Solubilization			
Alkaline	Extensive cell disruption at pH 12	Destruction of amide groups and unordered random coil conformation at pH 5.7-10.5	At pH 10 and application of Ca(OH) ₂ , hydrolysis of carbohydrate was not significantly affected	Solubilization and formation of negative charges	Saponification of lipids
Acidic	Limited cell membrane disruption	Denaturation and hydrolysis	Solubilization (but in a lower extent as alkaline)	Precipitation	Hydrolysis of esters

AOPs	Potential damage to cells by lipid peroxidation	Inactivation of proteins by modification of amino acid. In the absence of oxygen, cross-linking was observed		Production of inorganic carbon	
Biological	No cell lysis	With protease, very limited solubilization and degradation into amino acids	With amylase, limited solubilization, but relatively higher than proteins	Limited solubilization probably because of destruction of humic acid and protein complexes	

Table 2.14 Qualitative assessment of the effect of different pre-treatments on the sludge characteristics regarding degradability and economic feasibility.

Pre-treatment technique	Hydrolysis rate (k_{hyd})	Biodegradation (B_0)	VS removal	Dewaterability of digestate	Economical potential for increased methane production	Economical potential for increased VFA production	Investment costs	Operational costs
Thermal <100°C	↑↑	↑/↓	↑	↓	↑	↑/↓	Low	Low
TPAD	↑↑	↑↑	↑↑	↑	↑↑	↑/↓	Low	Low
Thermal >100°C	↑↑	↑↑	↑↑	↑	↑↑	↓	High	High
Microwave	↑/↓	↑↑	↑↑	↑	↑	↑/↓	High	High
Freeze and thaw	n/f (increase is expected)	↑	↑	n/f (improvement is expected)	↑/↓	↑/↓	Low/High	Low/High
Ultrasonic	↑↑	↑	↑	↓	↓	↓	High	High
Hydrodynamic cavitation, milling and homogenization	↑	↑	↑↑	↑	↑	↑/↓	Low	Low/High
Alkaline	↑/↓	↑	↑↑	↓	↑/↓	↑↑	Low	High
Acidic	↑/↓	↑	=	↑	↓	↓	High	High
AOPs	↑/↓	↑/↓	↑↑	↑	↑/↓	↑/↓	High	High
Biological	↑	↑/↓	n/f (increase is expected)	n/f (improvement is expected)	↑/↓	↑/↓	Low	High

Notes:

↑ increase

↓ decrease

= no change

n/f: not found in literature

2.5 References

- Ahn, K.H., Park, K.Y., Maeng, S.K., Hwang, J.H., Lee, J.W., Song, K.G., Choi, S., 2002. Ozonation of wastewater sludge for reduction and recycling. *Water Sci. Technol.* 46, 71–77.
- Angelidaki, I., Alves, M., Bolzonella, D., Borzacconi, L., Campos, J.L., Guwy, A.J., Kalyuzhnyi, S., Jenicek, P., Van Lier, J.B., 2009. Defining the biomethane potential (BMP) of solid organic wastes and energy crops: A proposed protocol for batch assays. *Water Sci. Technol.* 59, 927–934. doi:10.2166/wst.2009.040
- Angelidaki, I., Sanders, W., 2004. Assessment of the anaerobic biodegradability of macropollutants. *Rev. Environ. Sci. Biotechnol.* 3, 117–129.
- Anson, M.L., 1938. The estimation of pepsin, trypsin, papain, and cathepsin with hemoglobin. *J. Gen. Physiol.* 22, 79–89. doi:10.1085/jgp.22.1.79
- Appels, L., Degrève, J., Van der Bruggen, B., Van Impe, J., Dewil, R., 2010. Influence of low temperature thermal pre-treatment on sludge solubilisation, heavy metal release and anaerobic digestion. *Bioresour. Technol.* 101, 5743–5748. doi:10.1016/j.biortech.2010.02.068
- Appels, L., Houtmeyers, S., Degrève, J., van Impe, J., Dewil, R., 2013. Influence of microwave pre-treatment on sludge solubilization and pilot scale semi-continuous anaerobic digestion. *Bioresour. Technol.* 128, 598–603. doi:10.1016/j.biortech.2012.11.007
- Appels, L., van Assche, A., Willems, K., Degrève, J., van Impe, J., Dewil, R., 2011. Peracetic acid oxidation as an alternative pre-treatment for the anaerobic digestion of waste activated sludge. *Bioresour. Technol.* 102, 4124–4130. doi:10.1016/j.biortech.2010.12.070
- Apul, O.G., Sanin, F.D., 2010. Ultrasonic pretreatment and subsequent anaerobic digestion under different operational conditions. *Bioresour. Technol.* 101, 8984–8992. doi:10.1016/j.biortech.2010.06.128
- Azman, S., Khadem, A.F., van Lier, J.B., Zeeman, G., Plugge, C.M., Azman, S., Khadem, A.F., Lier, J.B. Van, Zeeman, G., 2015a. Presence and role of anaerobic hydrolytic microbes in conversion of lignocellulosic biomass for biogas production presence and role of anaerobic hydrolytic microbes in conversion of lignocellulosic biomass for biogas production. *Crit. Rev. Environ. Sci. Technol.* 45, 2523–2564. doi:10.1080/10643389.2015.1053727
- Azman, S., Khadem, A.F., Zeeman, G., van Lier, J.B., 2015b. Mitigation of humic acid inhibition in anaerobic digestion of cellulose by addition of various salts. *Bioengineering* 2(2), 54–65. doi:10.3390/bioengineering2020054
- Baier, U., Schmidheiny, P., 1997. Enhanced anaerobic degradation of mechanically disintegrated sludge. *Water Sci. Technol.* 36, 137–143. doi:10.1016/S0273-1223(97)00678-1
- Bao, H., Jiang, L., Chen, C., Yang, C., He, Z., Feng, Y., Cai, W., Liu, W., Wang, A., 2015. Combination of ultrasound and Fenton treatment for improving the hydrolysis and acidification of waste activated sludge. *RSC Adv.* 5, 48468–48473. doi:10.1039/c5ra05791d
- Bayr, S., Kaparaju, P., Rintala, J., 2013. Screening pretreatment methods to enhance thermophilic anaerobic digestion of pulp and paper mill wastewater treatment secondary sludge. *Chem. Eng. J.* 223, 479–486. doi:10.1016/j.cej.2013.02.119
- Blondeau, R., 1989. Biodegradation of natural and synthetic humic acids by the white rot fungus *Phanerochaete chrysosporium*. *Appl. Environ. Microbiol.* 55, 1282–5.
- Bobleter, O., 1994. Hydrothermal degradation of polymers derived from plants. *Prog. Polym. Sci.* 19, 797–841. doi:10.1016/0079-6700(94)90033-7
- Bolzonella, D., Cavinato, C., Fatone, F., Pavan, P., Cecchi, F., 2012. High rate mesophilic, thermophilic, and temperature phased anaerobic digestion of waste activated sludge: A pilot scale study. *Waste Manag.* 32, 1196–1201. doi:10.1016/j.wasman.2012.01.006
- Bolzonella, D., Pavan, P., Zanette, M., Cecchi, F., 2007. Two-phase anaerobic digestion of waste activated

- sludge: effect of an extreme thermophilic prefermentation. *Ind. Eng. Chem. Res.* 46, 6650–6655. doi:10.1021/ie061627e
- Bougrier, C., Albasi, C., Delgenès, J.P., Carrère, H., 2006. Effect of ultrasonic, thermal and ozone pre-treatments on waste activated sludge solubilisation and anaerobic biodegradability. *Chem. Eng. Process. Process Intensif.* 45, 711–718. doi:10.1016/j.cep.2006.02.005
- Bougrier, C., Battimelli, A., Delgenes, J.P., Carrere, H., 2007a. Combined ozone pretreatment and anaerobic digestion for the reduction of biological sludge production in wastewater treatment. *Ozone Sci. Eng.* 29, 201–206. doi:10.1080/01919510701296754
- Bougrier, C., Delgenes, J.P., Carrere, H., 2007b. Impacts of thermal pre-treatments on the semi-continuous anaerobic digestion of waste activated sludge. *Biochem. Eng. J.* 34, 20–27. doi:10.1016/j.bej.2006.11.013
- Bougrier, C., Delgenès, J.P., Carrère, H., 2008. Effects of thermal treatments on five different waste activated sludge samples solubilisation, physical properties and anaerobic digestion. *Chem. Eng. J.* 139, 236–244. doi:10.1016/j.cej.2007.07.099
- Bourven, I., Costa, G., Guibaud, G., 2012. Qualitative characterization of the protein fraction of exopolymeric substances (EPS) extracted with EDTA from sludge. *Bioresour. Technol.* 104, 486–496. doi:10.1016/j.biortech.2011.11.033
- Braguglia, C.M., Gianico, A., Gallipoli, A., Mininni, G., 2015. The impact of sludge pre-treatments on mesophilic and thermophilic anaerobic digestion efficiency: Role of the organic load. *Chem. Eng. J.* 270, 362–371. doi:10.1016/j.cej.2015.02.037
- Braguglia, C.M., Gianico, A., Mininni, G., 2012. Comparison between ozone and ultrasound disintegration on sludge anaerobic digestion. *J. Environ. Manage.* 95, S139–S143. doi:10.1016/j.jenvman.2010.07.030
- Brown, M.J., Lester, J.N., 1980. Comparison of bacterial extracellular polymer extraction methods comparison of bacterial extracellular polymer extraction methods. *Appl. Environ. Microbiol.* 40, 179–185.
- Burgess, J.E., Pletschke, B.I., 2008. Hydrolytic enzymes in sewage sludge treatment: A mini-review. *Water S A* 34, 343–350.
- Cella, M.A., Akgul, D., Eskicioglu, C., 2015. Assessment of microbial viability in municipal sludge following ultrasound and microwave pretreatments and resulting impacts on the efficiency of anaerobic sludge digestion. *Appl. Microbiol. Biotechnol.* 1–14. doi:10.1007/s00253-015-7139-3
- Cesbron, D., Déléris, S., Debellefontaine, H., Roustan, M., Paul, E., 2003. Study of competition for ozone between soluble and particulate matter during activated sludge ozonation. *Chem. Eng. Res. Des.* 81, 1165–1170. doi:http://dx.doi.org/10.1205/026387603770866335
- Chang, B.S., Kendrick, B.S., Carpenter, J.F., 1996. Surface-induced denaturation of proteins during freezing and its inhibition by surfactants. *J. Pharm. Sci.* 85, 1325–1330. doi:10.1021/js960080y
- Chang, C.J., Tyagi, V.K., Lo, S.L., 2011. Effects of microwave and alkali induced pretreatment on sludge solubilization and subsequent aerobic digestion. *Bioresour. Technol.* 102, 7633–7640. doi:10.1016/j.biortech.2011.05.031
- Chang, C.N., Ma, Y.S., Lo, C.W., 2002. Application of oxidation-reduction potential as a controlling parameter in waste activated sludge hydrolysis. *Chem. Eng. J.* 90, 273–281. doi:10.1016/S1385-8947(02)00015-3
- Charton, M., 1975. Steric effects. I. Esterification and acid-catalyzed hydrolysis of esters. *J. Am. Chem. Soc.* 97, 1552–1556. doi:10.1021/ja00839a047
- Chatel, G., 2016. Sonochemistry: New opportunities for green chemistry. World Scientific Publishing Europe, London.
- Chen, Y., Cheng, J.J., Creamer, K.S., 2008. Inhibition of anaerobic digestion process: A review. *Bioresour. Technol.* 99, 4044–4064. doi:10.1016/j.biortech.2007.01.057

- Chen, Y., Jiang, S., Yuan, H., Zhou, Q., Gu, G., 2007. Hydrolysis and acidification of waste activated sludge at different pHs. *Water Res.* 41, 683–9. doi:10.1016/j.watres.2006.07.030
- Chen, Y.R., Hashimoto, A.G., 1980. Substrate Utilization Kinetic Model for Biological Treatment Processes. *Biotechnol. Bioeng.* XXII, 2081–2095.
- Chi, Y., Li, Y., Fei, X., Wang, S., Yuan, H., 2011. Enhancement of thermophilic anaerobic digestion of thickened waste activated sludge by combined microwave and alkaline pretreatment. *J. Environ. Sci.* 23, 1257–1265. doi:10.1016/S1001-0742(10)60561-X
- Chiu, T., Chen, M., Chang, H., 2009. Comparisons of emulsifying properties of Maillard reaction products conjugated by green, red seaweeds and various commercial proteins. *Food Hydrocoll.* 23, 2270–2277. doi:10.1016/j.foodhyd.2009.06.003
- Chu, C.P., Chang, B.V., Liao, G.S., Jean, D.S., Lee, D.J., 2001. Observations on changes in ultrasonically treated waste-activated sludge. *Water Res.* 35, 1038–1046. doi:10.1016/S0043-1354(00)00338-9
- Chu, L.B., Yan, S.T., Xing, X.H., Yu, A.F., Sun, X.L., Jurcik, B., 2008. Enhanced sludge solubilization by microbubble ozonation. *Chemosphere* 72, 205–212. doi:10.1016/j.chemosphere.2008.01.054
- Climent, M., Ferrer, I., Baeza, M. del M., Artola, A., Vázquez, F., Font, X., 2007. Effects of thermal and mechanical pretreatments of secondary sludge on biogas production under thermophilic conditions. *Chem. Eng. J.* 133, 335–342. doi:10.1016/j.cej.2007.02.020
- Coelho, N.M.G., Droste, R.L., Kennedy, K.J., 2011. Evaluation of continuous mesophilic, thermophilic and temperature phased anaerobic digestion of microwaved activated sludge. *Water Res.* 45, 2822–34. doi:10.1016/j.watres.2011.02.032
- Comte, S., Guibaud, G., Baudu, M., 2006. Relations between extraction protocols for activated sludge extracellular polymeric substances (EPS) and EPS complexation properties: Part I. Comparison of the efficiency of eight EPS extraction methods. *Enzyme Microb. Technol.* 38, 237–245. doi:10.1016/j.enzmictec.2005.06.016
- Daniel, R.M., Dines, M., Petach, H.H., 1996. The denaturation and degradation of stable enzymes at high temperatures 11, 1–11.
- De Graaf, L.A., 2000. Denaturation of proteins from a non-food perspective. *J. Biotechnol.* 79, 299–306. doi:10.1016/S0168-1656(00)00245-5
- Déléris, S., Paul, E., Audic, J.M., Roustan, M., Debellefontaine, H., 2000. Effect of Ozonation on Activated Sludge Solubilization and Mineralization. *Ozone Sci. Eng.* 22, 473–486. doi:10.1080/01919510009408791
- Delmas, H., Le, N.T., Barthe, L., Julcour-Lebigue, C., 2014. Optimization of hydrostatic pressure at varied sonication conditions - power density, intensity, very low frequency - for isothermal ultrasonic sludge treatment. *Ultrason. Sonochem.* 25, 51–59. doi:10.1016/j.ultsonch.2014.08.011
- Demir, O., Filibeli, A., 2012. Fate of return activated sludge after ozonation: An optimization study for sludge disintegration. *Environ. Technol.* 33, 1869–78. doi:10.1080/09593330.2011.650220
- Devlin, D.C., Esteves, S.R.R., Dinsdale, R.M., Guwy, A.J., 2011. The effect of acid pretreatment on the anaerobic digestion and dewatering of waste activated sludge. *Bioresour. Technol.* 102, 4076–4082. doi:10.1016/j.biortech.2010.12.043
- Dhar, B.R., Nakhla, G., Ray, M.B., 2012. Techno-economic evaluation of ultrasound and thermal pretreatments for enhanced anaerobic digestion of municipal waste activated sludge. *Waste Manag.* 32, 542–549. doi:10.1016/j.wasman.2011.10.007
- Dhar, B.R., Youssef, E., Nakhla, G., Ray, M.B., 2011. Pretreatment of municipal waste activated sludge for volatile sulfur compounds control in anaerobic digestion. *Bioresour. Technol.* 102, 3776–3782. doi:10.1016/j.biortech.2010.12.020
- Diak, J., Örmeci, B., 2016. Individual and combined effects of freeze-thaw and ferrate(VI) oxidation for the treatment and dewatering of wastewater sludges. *Clean soil, air, water* 227, 1–16. doi:10.1007/s11270-016-3039-0

- Doğan, I., Sanin, F.D., 2009. Alkaline solubilization and microwave irradiation as a combined sludge disintegration and minimization method. *Water Res.* 43, 2139–2148. doi:10.1016/j.watres.2009.02.023
- Dong, B., Gao, P., Zhang, D., Chen, Y., Dai, L., Dai, X., 2015. A new process to improve short-chain fatty acids and bio-methane generation from waste activated sludge. *J. Environ. Sci.* doi:10.1016/j.jes.2015.10.004
- Donoso-Bravo, A., Pérez-Elvira, S., Aymerich, E., Fdz-Polanco, F., 2011. Assessment of the influence of thermal pre-treatment time on the macromolecular composition and anaerobic biodegradability of sewage sludge. *Bioresour. Technol.* 102, 660–666. doi:10.1016/j.biortech.2010.08.035
- Dwyer, J., Starrenburg, D., Tait, S., Barr, K., Batstone, D.J., Lant, P., 2008. Decreasing activated sludge thermal hydrolysis temperature reduces product colour, without decreasing degradability. *Water Res.* 42, 4699–4709. doi:10.1016/j.watres.2008.08.019
- Elliott, A., Mahmood, T., 2012. Comparison of mechanical pretreatment methods for the enhancement of anaerobic digestion of pulp and paper waste activated sludge. *Water Environ. Res.* 84, 497–505. doi:10.2175/106143012X13347678384602
- Ennouri, H., Miladi, B., Diaz, S.Z., Güelfo, L.A.F., Solera, R., Hamdi, M., Bouallagui, H., 2016. Effect of thermal pretreatment on the biogas production and microbial communities balance during anaerobic digestion of urban and industrial waste activated sludge. *Bioresour. Technol.* 214, 184–191. doi:10.1016/j.biortech.2016.04.076
- Erden, G., Filibeli, A., 2011. Effects of Fenton pre-treatment on waste activated sludge properties. *Clean soil, air, water* 39, 626–632. doi:10.1002/clen.201000199
- Erdinçler, A., Vesilind, P.A., 2000. Effect of sludge cell disruption on compactibility of biological sludges. *Water Sci. Technol.* 42, 119–126.
- Eskicioglu, C., Droste, R.L., Kennedy, K.J., 2007a. Performance of anaerobic waste activated sludge digesters after microwave pretreatment. *Water Environ. Res.* 79, 2265–2273. doi:10.2175/106143007X176004
- Eskicioglu, C., Kennedy, K.J., Droste, R.L., 2009. Enhanced disinfection and methane production from sewage sludge by microwave irradiation. *Desalination* 248, 279–285. doi:10.1016/j.desal.2008.05.066
- Eskicioglu, C., Kennedy, K.J., Droste, R.L., 2007b. Enhancement of batch waste activated sludge digestion by microwave pretreatment. *Water Environ. Res.* 79, 2304–2317. doi:10.2175/106143007X184069
- Eskicioglu, C., Kennedy, K.J., Droste, R.L., 2006. Characterization of soluble organic matter of waste activated sludge before and after thermal pretreatment. *Water Res.* 40, 3725–3736. doi:10.1016/j.watres.2006.08.017
- Eskicioglu, C., Prorot, A., Marin, J., Droste, R.L., Kennedy, K.J., 2008. Synergetic pretreatment of sewage sludge by microwave irradiation in presence of H₂O₂ for enhanced anaerobic digestion. *Water Res.* 42, 4674–4682. doi:10.1016/j.watres.2008.08.010
- Eskicioglu, C., Terzian, N., Kennedy, K.J., Droste, R.L., Hamoda, M., 2007c. Athermal microwave effects for enhancing digestibility of waste activated sludge. *Water Res.* 41, 2457–2466. doi:10.1016/j.watres.2007.03.008
- Fang, W., Zhang, P., Ye, J., Wu, Y., Zhang, H., Liu, J., Zhu, Y., Zeng, G., 2015. Physicochemical properties of sewage sludge disintegrated with high pressure homogenization. *Int. Biodeterior. Biodegradation* 102, 126–130. doi:10.1016/j.ibiod.2015.02.030
- Farr, S.B., Kogoma, T., 1991. Oxidative stress responses in *Escherichia coli* and *Salmonella typhimurium*. *Microbiol. Rev.* 55, 561–585.
- Feijoo, G., Soto, M., Méndez, R., Lema, J.M., 1995. Sodium inhibition in the anaerobic digestion process: Antagonism and adaptation phenomena. *Enzyme Microb. Technol.* 17, 180–188. doi:10.1016/0141-0229(94)00011-F

- Feng, X., Lei, H., Deng, J., Yu, Q., Li, H., 2009. Physical and chemical characteristics of waste activated sludge treated ultrasonically. *Chem. Eng. Process. Process Intensif.* 48, 187–194. doi:10.1016/j.cep.2008.03.012
- Fernandes, T. V., van Lier, J.B., Zeeman, G., 2015. Humic acid-like and fulvic acid-like inhibition on the hydrolysis of cellulose and tributyrin. *Bioenergy Res.* 8, 821–831. doi:10.1007/s12155-014-9564-z
- Foladori, P., Bruni, L., Tamburini, S., Ziglio, G., 2010. Direct quantification of bacterial biomass in influent, effluent and activated sludge of wastewater treatment plants by using flow cytometry. *Water Res.* 44, 3807–3818. doi:10.1016/j.watres.2010.04.027
- Foladori, P., Laura, B., Gianni, A., Giuliano, Z., 2007. Effects of sonication on bacteria viability in wastewater treatment plants evaluated by flow cytometry—Fecal indicators, wastewater and activated sludge. *Water Res.* 41, 235–243. doi:10.1016/j.watres.2006.08.021
- Foladori, P., Velho, V.F., Costa, R.H.R., Bruni, L., Quaranta, A., Andreottola, G., 2015. Concerning the role of cell lysis-cryptic growth in anaerobic side-stream reactors: The single-cell analysis of viable, dead and lysed bacteria. *Water Res.* 74, 132–142. doi:10.1016/j.watres.2015.01.042
- Folke, J., Renberg, L., McCubbin, N., 1996. Environmental aspects of ECF vs. TCF pulp bleaching, Environmental Fate and Effects of Pulp and Paper Mill Effluents.
- Forster, S., Snape, J.R., Lappin-Scott, H.M., Porter, J., 2002. Simultaneous fluorescent gram staining and activity assessment of activated sludge bacteria. *Appl. Environ. Microbiol.* 68, 4772–4779. doi:10.1128/AEM.68.10.4772-4779.2002
- Friedman, M., 1996. Food browning and its prevention: An overview. *J. Agric. Food Chem.* 44, 631–653. doi:10.1021/jf950394r
- Frølund, B., Griebe, T., Nielsen, P.H., 1995. Enzymatic activity in the activated-sludge floc matrix. *Appl. Microbiol. Biotechnol.* 43, 755–761.
- Frølund, B., Palmgren, R., Keiding, K., Nielsen, P.H., 1996. Extraction of extracellular polymers from activated sludge using a cation exchange resin. *Water Res.* 30, 1749–1758. doi:10.1016/0043-1354(95)00323-1
- Gao, W., 2011. Freezing as a combined wastewater sludge pretreatment and conditioning method. *Desalination* 268, 170–173. doi:10.1016/j.desal.2010.10.014
- Gao, Z., Zhang, C., Su, H., Tan, T., 2013. Live steam-pretreatment and anaerobic digestion of waste activated sludge. *Environ. Eng. Sci.* 30, 546–554. doi:10.1089/ees.2012.0480
- Garrote, G., Domínguez, H., Parajó, J.C., 1999. Hydrothermal processing of lignocellulosic materials. *Holz als Roh- und Werkst.* 57, 191–202. doi:10.1007/s001070050039
- Gavala, H.N., Yenal, U., Skiadas, I. V., Westermann, P., Ahring, B.K., 2003. Mesophilic and thermophilic anaerobic digestion of primary and secondary sludge. Effect of pre-treatment at elevated temperature. *Water Res.* 37, 4561–72. doi:10.1016/S0043-1354(03)00401-9
- Ge, H., Jensen, P.D., Batstone, D.J., 2011a. Increased temperature in the thermophilic stage in temperature phased anaerobic digestion (TPAD) improves degradability of waste activated sludge. *J. Hazard. Mater.* 187, 355–361. doi:10.1016/j.jhazmat.2011.01.032
- Ge, H., Jensen, P.D., Batstone, D.J., 2011b. Temperature phased anaerobic digestion increases apparent hydrolysis rate for waste activated sludge. *Water Res.* 45, 1597–1606. doi:10.1016/j.watres.2010.11.042
- Ghabbour, E.A., Davies, G., 2001. Humic substances: structures, models and functions. Royal Society of Chemistry.
- Ghasimi, D.S.M., Aboudi, K., de Kreuk, M., Zandvoort, M.H., van Lier, J.B., 2016a. Impact of lignocellulosic-waste intermediates on hydrolysis and methanogenesis under thermophilic and mesophilic conditions. *Chem. Eng. J.* 295, 181–191. doi:10.1016/j.cej.2016.03.045
- Ghasimi, D.S.M., de Kreuk, M., Maeng, S.K., Zandvoort, M.H., van Lier, J.B., 2016b. High-rate thermophilic bio-methanation of the fine sieved fraction from Dutch municipal raw sewage: Cost-

- effective potentials for on-site energy recovery. *Appl. Energy* 165, 569–582. doi:10.1016/j.apenergy.2015.12.065
- Gianico, A., Braguglia, C.M., Cesarini, R., Mininni, G., 2013. Reduced temperature hydrolysis at 134 °C before thermophilic anaerobic digestion of waste activated sludge at increasing organic load. *Bioresour. Technol.* 143, 96–103. doi:10.1016/j.biortech.2013.05.069
- Goldstone, J. V., Pullin, M.J., Bertilsson, S., Voelker, B.M., 2002. Reactions of hydroxyl radical with humic substances: Bleaching, mineralization, and production of bioavailable carbon substrates. *Environ. Sci. Technol.* 36, 364–372. doi:10.1021/es0109646
- Gong, C., Jiang, J., Li, D., Tian, S., 2015. Ultrasonic application to boost hydroxyl radical formation during Fenton oxidation and release organic matter from sludge. *Sci. Rep.* 5, 11419. doi:10.1038/srep11419
- Guan, B., Yu, J., Fu, H., Guo, M., Xu, X., 2012. Improvement of activated sludge dewaterability by mild thermal treatment in CaCl₂ solution. *Water Res.* 46, 425–432. doi:10.1016/j.watres.2011.11.014
- Guo, H., Fang, J., Felz, S., Lin, Y., van Lier, J.B., de Kreuk, M., (Unpublished results,), n.d. Anaerobic degradation of structural extracellular polymeric substances: a comparison between flocculated activated sludge and aerobic granules.
- Guo, X., Liu, J., Xiao, B., 2014. Evaluation of the damage of cell wall and cell membrane for various extracellular polymeric substance extractions of activated sludge. *J. Biotechnol.* 188, 130–135. doi:10.1016/j.jbiotec.2014.08.025
- Hansen, K.H., Angelidaki, I., Ahring, B.K., 1998. Anaerobic digestion of swine manure: Inhibition by ammonia. *Water Res.* 32, 5–12. doi:10.1016/S0043-1354(97)00201-7
- Haug, R.T., Stuckey, D.C., Gossett, J.M., McCarty, P.L., 1978. Effect of thermal pretreatment on digestibility and dewaterability of organic sludges. *J. Water Pollut. Control Fed.* 50, 73–85.
- He, Z.-W., Yang, C.-X., Wang, L., Guo, Z.-C., Wang, A.-J., Liu, W.-Z., 2016. Feasibility of short-term fermentation for short-chain fatty acids production from waste activated sludge at initial pH10: Role and significance of rhamnolipid. *Chem. Eng. J.* 290, 125–135. doi:10.1016/j.cej.2016.01.033
- Heller, M.C., Carpenter, J.F., Randolph, T.W., 1999. Protein formulation and lyophilization cycle design: Prevention of damage due to freeze-concentration induced phase separation. *Biotechnol. Bioeng.* 63, 166–174. doi:10.1002/(SICI)1097-0290(19990420)63:2<166::AID-BIT5>3.0.CO;2-H
- Hellström, D., 1997. Natural sludge dewatering. II: Thawing-drying process in full-scale sludge freezing ditches. *J. Cold Reg. Eng.* 11, 15–29.
- Hiraoka, M., Takeda, N., Sakai, S., Yasuda, A., 1985. Highly efficient anaerobic digestion with thermal pretreatment. *Water Sci. Technol.* 17, 529–539.
- Hirooka, K., Asano, R., Yokoyama, A., Okazaki, M., Sakamoto, A., Nakai, Y., 2009. Reduction in excess sludge production in a dairy wastewater treatment plant via nozzle-cavitation treatment: Case study of an on-farm wastewater treatment plant. *Bioresour. Technol.* 100, 3161–3166. doi:10.1016/j.biortech.2009.01.011
- Holliger, C., Alves, M., Andrade, D., Angelidaki, I., Astals, S., Baier, U., Bougrier, C., Buffiere, P., Carballa, M., de Wilde, V., Ebertseder, F., Fernandez, B., Ficara, E., Fotidis, I., Frigon, J.-C., de Lacroix, H.F., Ghasimi, D.S.M., Hack, G., Hartel, M., Heerenklage, J., Horvath, I.S., Jenicek, P., Koch, K., Krautwald, J., Lizasoain, J., Liu, J., Mosberger, L., Nistor, M., Oechsner, H., Oliveira, J. V., Paterson, M., Paus, A., Pommier, S., Porqueddu, I., Raposo, F., Ribeiro, T., Rusch Pfund, F., Stromberg, S., Torrijos, M., van Eekert, M., van Lier, J., Wedwitschka, H., Wierinck, I., 2016. Towards a standardization of biomethane potential tests. *Water Sci. Technol.* 1–9. doi:10.2166/wst.2016.336
- Hong, S.M., Park, J.K., Lee, Y.O., 2004. Mechanisms of microwave irradiation involved in the destruction of fecal coliforms from biosolids. *Water Res.* 38, 1615–1625. doi:10.1016/j.watres.2003.12.011
- Hong, S.M., Park, J.K., Teeradej, N., Lee, Y.O., Cho, Y.K., Park, C.H., 2006. Pretreatment of sludge with microwaves for pathogen destruction and improved anaerobic digestion performance. *Water*

- Environ. Res. 78, 76–83. doi:10.2175/106143005X84549
- Horton, D., Philips, K.D., 1973. The nitrous acid deamination of glycosides and acetates of 2-amino-2-deoxy-D-glucose. *Carbohydr. Res.* 30, 367–374. doi:10.1016/S0008-6215(00)81823-6
- Hosseini Koupaie, E., Eskicioglu, C., 2016. Conventional heating vs. microwave sludge pretreatment comparison under identical heating/cooling profiles for thermophilic advanced anaerobic digestion. *Waste Manag.* doi:10.1016/j.wasman.2016.04.014
- Hosseini Koupaie, E., Johnson, T., Eskicioglu, C., 2017. Advanced anaerobic digestion of municipal sludge using a novel and energy-efficient radio frequency pretreatment system. *Water Res.* 118, 70–81. doi:10.1016/j.watres.2017.04.017
- Hu, K., Jiang, J.Q., Zhao, Q.L., Lee, D.J., Wang, K., Qiu, W., 2011. Conditioning of wastewater sludge using freezing and thawing: Role of curing. *Water Res.* 45, 5969–5976. doi:10.1016/j.watres.2011.08.064
- Huan, L., Yiyang, J., Mahar, R.B., Zhiyu, W., Yongfeng, N., 2009. Effects of ultrasonic disintegration on sludge microbial activity and dewaterability. *J. Hazard. Mater.* 161, 1421–1426. doi:10.1016/j.jhazmat.2008.04.113
- Jahn, A., Nielsen, P.H., 1998. Cell biomass and exopolymer composition in sewer biofilms. *Water Sci. Technol.* 37, 17–24.
- Jan, T.W., Adav, S.S., Lee, D.J., Wu, R.M., Su, A., Tay, J.H., 2008. Hydrogen fermentation and methane production from sludge with pretreatments. *Energy and Fuels* 22, 98–102. doi:10.1021/ef700278j
- Jaziri, K., Casellas, M., Dagot, C., 2012. Comparing the effects of three pre-treatment disintegration techniques on aerobic sludge digestion: biodegradability enhancement and microbial community monitoring by PCR-DGGE. *Environ. Technol.* 33, 1435–44. doi:10.1080/09593330.2011.632653
- Jiang, J., Yang, S., Chen, M., Zhang, Q., 2009. Disintegration of sewage sludge with bifrequency ultrasonic treatment. *Water Sci. Technol.* 60, 1445–1453. doi:10.2166/wst.2009.469
- Jin, B., Wilén, B.M., Lant, P., 2004. Impacts of morphological, physical and chemical properties of sludge flocs on dewaterability of activated sludge. *Chem. Eng. J.* 98, 115–126. doi:10.1016/j.cej.2003.05.002
- Jin, Y., Li, H., Mahar, R.B., Wang, Z., Nie, Y., 2009. Combined alkaline and ultrasonic pretreatment of sludge before aerobic digestion. *J. Environ. Sci.* 21, 279–284. doi:10.1016/S1001-0742(08)62264-0
- Joo, S.H., Dello Monaco, F., Antmann, E., Chorath, P., 2015. Sustainable approaches for minimizing biosolids production and maximizing reuse options in sludge management: A review. *J. Environ. Manage.* 158, 133–45. doi:10.1016/j.jenvman.2015.05.014
- Jorand, F., Zartarian, F., Thomas, F., Block, J.C., Bottero, J.Y., Villemin, G., Urbain, V., Manem, J., 1995. Chemical and structural (2D) linkage between bacteria within activated sludge flocs. *Water Res.* 29, 1639–1647. doi:10.1016/0043-1354(94)00350-G
- Jung, H., Kim, J., Lee, S., Lee, C., 2014. Effect of mild-temperature H₂O₂ oxidation on solubilization and anaerobic digestion of waste activated sludge. *Environ. Technol.* 35, 1702–9. doi:10.1080/09593330.2014.880517
- Jung, J., Xing, X.H., Matsumoto, K., 2001. Kinetic analysis of disruption of excess activated sludge by Dyno Mill and characteristics of protein release for recovery of useful materials. *Biochem. Eng. J.* 8, 1–7. doi:10.1016/S1369-703X(00)00123-6
- Kakita, Y., Kashige, N., Murata, K., Kuroiwa, A., Funatsu, M., Watanabe, K., 1995. Inactivation microwave of lactobacillus bacteriophage irradiation PL-1 by microwave irradiation. *Microbiol. Immunol.* 39, 571–576.
- Karshikoff, A., Nilsson, L., Ladenstein, R., 2015. Rigidity versus flexibility: the dilemma of understanding protein thermal stability. *FEBS J* 282, 3899–3917. doi:10.1111/febs.13343
- Kavitha, S., Jayashree, C., Adish Kumar, S., Yeom, I.T., Rajesh Banu, J., 2014. The enhancement of anaerobic biodegradability of waste activated sludge by surfactant mediated biological pretreatment. *Bioresour. Technol.* 168, 159–166. doi:10.1016/j.biortech.2014.01.118

- Kavitha, S., Stella, P.B.C., Kaliappan, S., Yeom, I.T., Banu, J.R., 2016. Enhancement of anaerobic degradation of sludge biomass through surfactant-assisted bacterial hydrolysis. *Process Saf. Environ. Prot.* 99, 207–215. doi:10.1016/j.psep.2015.11.009
- Kennedy, K.J., Thibault, G., Droste, R.L., 2007. Microwave enhanced digestion of aerobic SBR sludge. *Water SA* 33, 261–270. doi:10.4314/wsa.v33i2.49085
- Kent, J.A., 2013. *Handbook of industrial chemistry and biotechnology*. Springer Science & Business Media.
- Kianmehr, P., Parker, W., Seto, P., 2013. Assessment of waste-activated-sludge pretreatment by ultrasound and applicability of biodegradability indicators. *J. Environ. Eng.* 139, 545–553. doi:10.1061/(ASCE)EE .1943-7870.0000657
- Kim, D.-H., Cho, S.K., Lee, M.K., Kim, M.S., 2013. Increased solubilization of excess sludge does not always result in enhanced anaerobic digestion efficiency. *Bioresour. Technol.* 143, 660–664. doi:10.1016/j.biortech.2013.06.058
- Kim, D.H., Jeong, E., Oh, S.E., Shin, H.S., 2010. Combined (alkaline+ultrasonic) pretreatment effect on sewage sludge disintegration. *Water Res.* 44, 3093–3100. doi:10.1016/j.watres.2010.02.032
- Kim, H.J., Nguyen, D.X., Bae, J.H., 2008. The performance of the sludge pretreatment system with venturi tubes. *Water Sci. Technol.* 57, 131–137. doi:10.2166/wst.2008.717
- Kim, J., Park, C., Kim, T.-H., Lee, M., Kim, S., Kim, S.-W., Lee, J., 2003. Effects of various pretreatments for enhanced anaerobic digestion with waste activated sludge. *J. Biosci. Bioeng.* 95, 271–275. doi:10.1263/jbb.95.271
- Kim, J., Yu, Y., Lee, C., 2013. Thermo-alkaline pretreatment of waste activated sludge at low-temperatures: Effects on sludge disintegration, methane production, and methanogen community structure. *Bioresour. Technol.* 144, 194–201. doi:10.1016/j.biortech.2013.06.115
- Kinnunen, V., Craggs, R., Rintala, J., 2014. Influence of temperature and pretreatments on the anaerobic digestion of wastewater grown microalgae in a laboratory-scale accumulating-volume reactor. *Water Res.* 57, 247–257. doi:10.1016/j.watres.2014.03.043
- Kobayashi, T., Li, Y.Y., Harada, H., Yasui, H., Noike, T., 2009. Upgrading of the anaerobic digestion of waste activated sludge by combining temperature-phased anaerobic digestion and intermediate ozonation. *Water Sci. Technol.* 59, 185–193. doi:10.2166/wst.2009.510
- Kohanski, M.A., Dwyer, D.J., Hayete, B., Lawrence, C.A., Collins, J.J., 2007. A common mechanism of cellular death induced by bactericidal antibiotics. *Cell* 130, 797–810. doi:10.1016/j.cell.2007.06.049
- Kolokassidou, C., Pashalidis, I., Costa, C.N., Efstathiou, A.M., Buckau, G., 2007. Thermal stability of solid and aqueous solutions of humic acid. *Thermochim. Acta* 454, 78–83. doi:10.1016/j.tca.2006.12.022
- Kroiss, H., 2004. What is the potential for utilizing the resources in sludge? *Water Sci. Technol.* 49, 1–10.
- Kuglarz, M., Karakashev, D., Angelidaki, I., 2013. Microwave and thermal pretreatment as methods for increasing the biogas potential of secondary sludge from municipal wastewater treatment plants. *Bioresour. Technol.* 134, 290–297. doi:10.1016/j.biortech.2013.02.001
- Kumar, P.S., Pandit, A.B., 1999. Modeling Hydrodynamic Cavitation. *Chem. Eng. Technol.* 22, 1017–1027. doi:10.1002/(SICI)1521-4125(199912)22:12<1017::AID-CEAT1017>3.0.CO;2-L
- Lajapathi Rai, C., Mueller, J., Struenkmann, G., Gangadhar Rao, P., 2008. Microbial growth reduction in sewage sludge by stirred ball mill disintegration and estimation by respirometry. *J. Chem. Technol. Biotechnol.* 83, 269–278. doi:10.1002/jctb.1803
- Laurent, J., Pierra, M., Casellas, M., Dagot, C., 2009a. Fate of cadmium in activated sludge after changing its physico-chemical properties by thermal treatment. *Chemosphere* 77, 771–777. doi:10.1016/j.chemosphere.2009.08.024
- Laurent, J., Pierra, M., Casellas, M., Pons, M.N., Dagot, C., 2009b. Activated sludge properties after ultrasonic and thermal treatments and their potential influence on dewaterability. *J. Residuals Sci. Technol.* 6, 19–25.

- Lee, I., Han, J.I., 2013. The effects of waste-activated sludge pretreatment using hydrodynamic cavitation for methane production. *Ultrason. Sonochem.* 20, 1450–1455. doi:10.1016/j.ultsonch.2013.03.006
- Leite, W.R.M., Gottardo, M., Pavan, P., Belli Filho, P., Bolzonella, D., 2016. Performance and energy aspects of single and two phase thermophilic anaerobic digestion of waste activated sludge. *Renew. Energy* 86, 1324–1331. doi:10.1016/j.renene.2015.09.069
- Li, H., Jin, Y., Mahar, R., Wang, Z., Nie, Y., 2008. Effects and model of alkaline waste activated sludge treatment. *Bioresour. Technol.* 99, 5140–4. doi:10.1016/j.biortech.2007.09.019
- Li, X., Zhao, J., Wang, D., Yang, Q., Xu, Q., Deng, Y., Yang, W., Zeng, G., 2016. An efficient and green pretreatment to stimulate short-chain fatty acids production from waste activated sludge anaerobic fermentation using free nitrous acid. *Chemosphere* 144, 160–167. doi:10.1016/j.chemosphere.2015.08.076
- Li, Y., Hu, Y., Wang, G., Lan, W., Lin, J., Bi, Q., Shen, H., Liang, S., 2014. Screening pretreatment methods for sludge disintegration to selectively reclaim carbon source from surplus activated sludge. *Chem. Eng. J.* 255, 365–371. doi:10.1016/j.cej.2014.06.034
- Li, Y.Y., Noike, T., 1992. Upgrading of anaerobic digestion of waste activated sludge by thermal pretreatment. *Water Sci. Technol.* 26, 857–866. doi:10.1016/j.energy.2015.04.110
- Liao, B.Q., Allen, D.G., Leppard, G.G., Droppo, I.G., Liss, S.N., 2002. Interparticle interactions affecting the stability of sludge flocs. *J. Colloid Interface Sci.* 249, 372–80. doi:10.1006/jcis.2002.8305
- Liao, X., Li, H., Zhang, Y., Liu, C., Chen, Q., 2016. Accelerated high-solids anaerobic digestion of sewage sludge using low-temperature thermal pretreatment. *Int. Biodeterior. Biodegradation* 106, 141–149. doi:10.1016/j.ibiod.2015.10.023
- Lin, J.-G., Chang, C.-N., Chang, S.-C., 1997. Enhancement of anaerobic digestion of waste activated sludge by alkaline solubilization. *Bioresour. Technol.* 62, 85–90. doi:10.1016/S0960-8524(97)00121-1
- Liu, J., Jia, R., Wang, Y., Wei, Y., Zhang, J., Wang, R., Cai, X., 2015. Does residual H₂O₂ result in inhibitory effect on enhanced anaerobic digestion of sludge pretreated by microwave-H₂O₂ pretreatment process? *Environ. Sci. Pollut. Res.* 9016–9025. doi:10.1007/s11356-015-5704-z
- Martínez, E.J., Gil, M. V., Rosas, J.G., Moreno, R., Mateos, R., Morán, A., Gómez, X., 2016. Application of thermal analysis for evaluating the digestion of microwave pre-treated sewage sludge. *J. Therm. Anal. Calorim.* 127, 1209–1219. doi:10.1007/s10973-016-5460-4
- Matsumoto, M., Ohashi, K., 2003. Effect of immobilization on thermostability of lipase from *Candida rugosa*. *Biochem. Eng. J.* 14, 75–77. doi:10.1016/S1369-703X(02)00138-9
- Mehdizadeh, S.N., Eskicioglu, C., Bobowski, J., Johnson, T., 2013. Conductive heating and microwave hydrolysis under identical heating profiles for advanced anaerobic digestion of municipal sludge. *Water Res.* 47, 5040–5051. doi:10.1016/j.watres.2013.05.055
- Mikkelsen, L.H., Keiding, K., 2002. Physico-chemical characteristics of full scale sewage sludges with implications to dewatering. *Water Res.* 36, 2451–2462. doi:10.1016/S0043-1354(01)00477-8
- Montusiewicz, A., Lebiocka, M., Rozej, A., Zacharska, E., Pawłowski, L., 2010. Freezing/thawing effects on anaerobic digestion of mixed sewage sludge. *Bioresour. Technol.* 101, 3466–3473. doi:10.1016/j.biortech.2009.12.125
- Morgan-Sagastume, F., Pratt, S., Karlsson, A., Cirne, D., Lant, P., Werker, A., 2011. Production of volatile fatty acids by fermentation of waste activated sludge pre-treated in full-scale thermal hydrolysis plants. *Bioresour. Technol.* 102, 3089–3097. doi:10.1016/j.biortech.2010.10.054
- Mottet, A., Steyer, J.P., Déléris, S., Vedrenne, F., Chauzy, J., Carrère, H., 2009. Kinetics of thermophilic batch anaerobic digestion of thermal hydrolysed waste activated sludge. *Biochem. Eng. J.* 46, 169–175. doi:10.1016/j.bej.2009.05.003
- Müller, J.A., 2001. Prospects and problems of sludge pre-treatment processes. *Water Sci. Technol.* 44,

121–128.

- Müller, J.A., Winter, A., Strünkmann, G., 2004. Investigation and assessment of sludge pre-treatment processes. *Water Sci. Technol.* 49, 97–104.
- Münch, E. V., Pollard, P.C., 1997. Measuring bacterial biomass-COD in wastewater containing particulate matter. *Water Res.* 31, 2550–2556. doi:10.1016/S0043-1354(97)00089-4
- Nazari, L., Yuan, Z., Santoro, D., Sarathy, S., Ho, D., Batstone, D., Xu, C. (Charles), Ray, M.B., 2016. Low-temperature thermal pre-treatment of municipal wastewater sludge: Process optimization and effects on solubilization and anaerobic degradation. *Water Res.* 113, 111–123. doi:10.1016/j.watres.2016.11.055
- Neumann, P., Pesante, S., Venegas, M., Vidal, G., 2016. Developments in pre-treatment methods to improve anaerobic digestion of sewage sludge. *Rev. Environ. Sci. Biotechnol.* 15, 173–211. doi:10.1007/s11157-016-9396-8
- Neyens, E., Baeyens, J., 2003. A review of classic Fenton's peroxidation as an advanced oxidation technique. *J. Hazard. Mater.* 98, 33–50. doi:10.1016/S0304-3894(02)00282-0
- Nguyen, D.D., Yoon, Y.S., Nguyen, N.D., Bach, Q.V., Bui, X.T., Chang, S.W., Le, H.S., Guo, W., Ngo, H.H., 2016. Enhanced efficiency for better wastewater sludge hydrolysis conversion through ultrasonic hydrolytic pretreatment. *J. Taiwan Inst. Chem. Eng.* 71, 244–252. doi:10.1016/j.jtice.2016.12.019
- Nielsen, H.B., Thygesen, A., Thomsen, A.B., Schmidt, J.E., 2011. Anaerobic digestion of waste activated sludge-comparison of thermal pretreatments with thermal inter-stage treatments. *J. Chem. Technol. Biotechnol.* 86, 238–245. doi:10.1002/jctb.2509
- Nielsen, P.H., Frølund, B., Keiding, K., 1996. Changes in the composition of extracellular polymeric substances in activated sludge during anaerobic storage. *Appl. Microbiol. Biotechnol.* 44, 823–830. doi:10.1007/BF00178625
- Nielsen, P.H., Jahn, A., Palmgren, R., 1997. Conceptual model for production and composition of exopolymers in biofilms. *Water Sci. Technol.* 36, 11–19.
- Pabón Pereira, C.P., Castañares, G., Van Lier, J.B., 2012. An OxiTop® protocol for screening plant material for its biochemical methane potential (BMP). *Water Sci. Technol.* 66, 1416–1423. doi:10.2166/wst.2012.305
- Parawira, W., 2012. Enzyme research and applications in biotechnological intensification of biogas production. *Crit. Rev. Biotechnol.* 32, 172–186. doi:10.3109/07388551.2011.595384
- Park, B., Ahn, J.H., Kim, J., Hwang, S., 2004. Use of microwave pretreatment for enhanced anaerobiosis of secondary sludge. *Water Sci. Technol.* 50, 17–23.
- Park, W.J., Ahn, J.H., 2011. Optimization of microwave pretreatment conditions to maximize methane production and methane yield in mesophilic anaerobic sludge digestion. *Env. Technol.* 32, 1533–1540. doi:10.1080/09593330.2010.543929
- Parmar, N., Singh, A., Ward, O., 2001. Enzyme treatment to reduce solids and improve settling of sewage sludge. *J. Ind. Microbiol. Biotechnol.* 26, 383–386. doi:10.1038/sj.jim.7000150
- Penaud, V., Delgenes, J.P., Moletta, R., 1999. Thermo-chemical pretreatment of a microbial biomass: influence of sodium hydroxide addition on solubilization and anaerobic biodegradability. *Enzyme Microb. Technol.* 25, 258–263. doi:10.1080/09593332108618141
- Pérez-Elvira, S., Fdz-Polanco, M., Plaza, F.I., Garralón, G., Fdz-Polanco, F., 2009. Ultrasound pre-treatment for anaerobic digestion improvement. *Water Sci. Technol.* 60, 1525–1532. doi:10.2166/wst.2009.484
- Pérez-Elvira, S.I., Ferreira, L.C., Donoso-Bravo, A., Fdz-Polanco, M., Fdz-Polanco, F., 2010. Full-stream and part-stream ultrasound treatment effect on sludge anaerobic digestion. *Water Sci. Technol.* 61, 1363–1372. doi:10.2166/wst.2010.893
- Pérez-Elvira, S.I., Sapkaite, I., Fdz-Polanco, F., 2016. Separate digestion of liquid and solid fractions of thermally pretreated secondary sludge. assessment and global evaluation. *Brazilian J. Chem. Eng.*

- 33, 699–704. doi:10.1590/0104-6632.20160334s20150277
- Pijuan, M., Wang, Q., Ye, L., Yuan, Z., 2012. Improving secondary sludge biodegradability using free nitrous acid treatment. *Bioresour. Technol.* 116, 92–8. doi:10.1016/j.biortech.2012.04.016
- Pilli, S., Bhunia, P., Yan, S., LeBlanc, R.J., Tyagi, R.D., Surampalli, R.Y., 2011. Ultrasonic pretreatment of sludge: a review. *Ultrason. Sonochem.* 18, 1–18. doi:10.1016/j.ultsonch.2010.02.014
- Pilli, S., Yan, S., Tyagi, R.D., Surampalli, R.Y., 2016. Anaerobic digestion of ultrasonicated sludge at different solids concentrations - Computation of mass-energy balance and greenhouse gas emissions. *J. Environ. Manage.* 166, 374–386. doi:10.1016/j.jenvman.2015.10.041
- Pilli, S., Yan, S., Tyagi, R.D., Surampalli, R.Y., 2014. Thermal Pretreatment of Sewage Sludge to Enhance Anaerobic Digestion: A Review. *Crit. Rev. Environ. Sci. Technol.* 45, 669–702. doi:10.1080/10643389.2013.876527
- Pinnekamp, J., 1989. Effects of thermal pretreatment of sewage sludge on anaerobic digestion. *Water Sci. Technol.* 21, 97–108.
- Prorot, A., Julien, L., Christophe, D., Patrick, L., 2011. Sludge disintegration during heat treatment at low temperature: a better understanding of involved mechanisms with a multiparametric approach. *Biochem. Eng. J.* 54, 178–184. doi:10.1016/j.bej.2011.02.016
- Rajan, R.V., Lin, J.-G., Ray, B.T., 1988. Improved anaerobic digestion with low level chemical pretreatment, in: 43 Rd Industrial Waste Conference May 10-12, 1988. Lewis Publishers, Purdue University, West Lafayette, Indiana., pp. 327–337.
- Ray, B., Lin, J.-G., Rajan, R., 1990. Low-level alkaline solubilization for enhanced anaerobic digestion. *Res. J. Water Pollut. Control Fed.* 62, 81–87.
- Riau, V., De la Rubia, M.A., Pérez, M., 2012. Assessment of solid retention time of a temperature phased anaerobic digestion system on performance and final sludge characteristics. *J. Chem. Technol. Biotechnol.* 87, 1074–1082. doi:10.1002/jctb.3709
- Riffaldi, R., 1982. Humic substances in sewage sludges. *Environ. Pollut.* 139–146.
- Rombaut, N., Tixier, A.S., Bily, A., Chemat, F., 2014. Green extraction processes of natural products as tools for biorefinery. *Biofuels, Bioprod. Biorefining* 8, 530–544. doi:10.1002/bbb.1486
- Ruffino, B., Campo, G., Cerutti, A., Zanetti, M., Lorenzi, E., Scibilia, G., Genon, G., 2016. Preliminary technical and economic analysis of alkali and low temperature thermo-alkali pretreatments for the anaerobic digestion of waste activated sludge. *Waste Biomass Valorization* 7, 667–675. doi:10.1007/s12649-016-9537-x
- Ruffino, B., Campo, G., Genon, G., Lorenzi, E., Novarino, D., Scibilia, G., Zanetti, M., 2015. Improvement of anaerobic digestion of sewage sludge in a wastewater treatment plant by means of mechanical and thermal pre-treatments: Performance, energy and economical assessment. *Bioresour. Technol.* 175, 298–308. doi:10.1016/j.biortech.2014.10.071
- Sahinkaya, S., 2015. Disintegration of municipal waste activated sludge by simultaneous combination of acid and ultrasonic pretreatment. *Process Saf. Environ. Prot.* 93, 201–205. doi:10.1016/j.psep.2014.04.002
- Salsabil, M.R., Laurent, J., Casellas, M., Dagot, C., 2010. Techno-economic evaluation of thermal treatment, ozonation and sonication for the reduction of wastewater biomass volume before aerobic or anaerobic digestion. *J. Hazard. Mater.* 174, 323–333. doi:10.1016/j.jhazmat.2009.09.054
- Salsabil, M.R., Prorot, A., Casellas, M., Dagot, C., 2009. Pre-treatment of activated sludge: Effect of sonication on aerobic and anaerobic digestibility. *Chem. Eng. J.* 148, 327–335. doi:10.1016/j.cej.2008.09.003
- Salton, M.R.J., Horne, R.W., 1951. Studies of the bacterial cell wall. *Biochim. Biophys. Acta* 7, 19–42.
- Sanders, W.T.M., Geerink, M., Zeeman, G., Lettinga, G., 2000. Anaerobic hydrolysis kinetics of particulate substrates. *Water Sci. Technol.* 41, 17–24.
- Sapkaite, I., Barrado, E., Fdz-Polanco, F., Pérez-Elvira, S.I., 2017. Optimization of a thermal hydrolysis

- process for sludge pre-treatment. *J. Environ. Manage.* 192, 25–30.
doi:10.1016/j.jenvman.2017.01.043
- Schmid, M., Thill, A., Purkhold, U., Walcher, M., Bottero, J.Y., Ginestet, P., Nielsen, P.H., Wuertz, S., Wagner, M., 2003. Characterization of activated sludge flocs by confocal laser scanning microscopy and image analysis. *Water Res.* 37, 2043–2052. doi:10.1016/S0043-1354(02)00616-4
- Seng, B., Khanal, S.K., Visvanathan, C., 2010. Anaerobic digestion of waste activated sludge pretreated by a combined ultrasound and chemical process. *Environ. Technol.* 31, 257–65.
doi:10.1080/09593330903453236
- Serrano, A., Siles, J.A., Martín, M.A., Chica, A.F., Estévez-Pastor, F.S., Toro-Baptista, E., 2016. Improvement of anaerobic digestion of sewage sludge through microwave pre-treatment. *J. Environ. Manage.* 177, 231–239. doi:10.1016/j.jenvman.2016.03.048
- Sesay, M.L., Özcengiz, G., Dilek Sanin, F., 2006. Enzymatic extraction of activated sludge extracellular polymers and implications on bioflocculation. *Water Res.* 40, 1359–1366.
doi:10.1016/j.watres.2006.01.045
- Shao, L., Wang, X., Xu, H., He, P., 2012. Enhanced anaerobic digestion and sludge dewaterability by alkaline pretreatment and its mechanism. *J. Environ. Sci. (China)* 24, 1731–1738.
doi:10.1016/S1001-0742(11)61031-0
- Show, K.-Y., Mao, T., Lee, D., 2007. Optimisation of sludge disruption by sonication. *Water Res.* 41, 4741–4747. doi:10.1016/j.watres.2007.07.017
- Silvestre, G., Ruiz, B., Fiter, M., Ferrer, C., Berlanga, J.G., Alonso, S., Canut, A., 2015. Ozonation as a pre-treatment for anaerobic digestion of waste-activated sludge: Effect of the ozone doses. *Ozone Sci. Eng.* 37, 316–322. doi:10.1080/01919512.2014.985817
- Sólyom, K., Mato, R.B., Pérez-Elvira, S.I., Cocero, M.J., 2011. The influence of the energy absorbed from microwave pretreatment on biogas production from secondary wastewater sludge. *Bioresour. Technol.* 102, 10849–10854. doi:10.1016/j.biortech.2011.09.052
- Sotodate, J., Inaba, K.I., Tajima, H., Yamagiwa, K., 2009. Effect of ultrasonication on excess sludge bioavailability for methane production. *J. Chem. Eng. Japan* 42, 67–72.
- STOWA, 2013. Vervolgonderzoek slibdesintegratie RWZI Nieuwgraaf (In Dutch). Amersfoort.
- Stuckey, D.C., McCarty, P.L., 1984. The effect of thermal pretreatment on the anaerobic biodegradability and toxicity of waste activated sludge. *Water Res.* 18, 1343–1353. doi:10.1016/0043-1354(84)90002-2
- Su, G., Huo, M., Yuan, Z., Wang, S., Peng, Y., 2013. Hydrolysis, acidification and dewaterability of waste activated sludge under alkaline conditions: Combined effects of NaOH and Ca(OH)₂. *Bioresour. Technol.* 136, 237–243. doi:10.1016/j.biortech.2013.03.024
- Szwergold, B.S., 2013. Maillard reactions in hyperthermophilic archaea: implications for better understanding of non-enzymatic glycation in biology. *Rejuvenation Res.* 16, 259–72.
doi:10.1089/rej.2012.1401
- Taib, M.Y., Aziz, A.A., Alias, B.S., 2010. Performance analysis of a domestic refrigerator, National Conference in Mechanical Engineering Research and Postgraduate Students.
- Tan, W.F., Koopal, L.K., Weng, L.P., van Riemsdijk, W.H., Norde, W., 2008. Humic acid protein complexation. *Geochim. Cosmochim. Acta* 72, 2090–2099. doi:10.1016/j.gca.2008.02.009
- Thomashow, M.F., 1998. Role of cold-responsive genes in plant freezing tolerance. *Plant Physiol.* 118, 1–8. doi:10.1104/pp.118.1.1
- Tian, X., Trzcinski, A.P., Lin, L.L., Ng, W.J., 2015a. Impact of ozone assisted ultrasonication pre-treatment on anaerobic digestibility of sewage sludge. *J. Environ. Sci. (China)* 33, 29–38.
doi:10.1016/j.jes.2015.01.003
- Tian, X., Wang, C., Trzcinski, A.P., Lin, L., Ng, W.J., 2015b. Interpreting the synergistic effect in combined ultrasonication-ozonation sewage sludge pre-treatment. *Chemosphere* 140, 63–71.

doi:10.1016/j.chemosphere.2014.09.007

- Tiehm, A., Nickel, K., Zellhorn, M., Neis, U., 2001. Ultrasonic waste activated sludge disintegration for improving anaerobic stabilization. *Water Res.* 35, 2003–2009. doi:10.1016/S0043-1354(00)00468-1
- Tipton, H., Powell, J., Town, R.M., 1992. Solubility and fractionation of humic acid; effect of pH and ionic medium. *Anal. Chumca Acta* 267, 47–54. doi:10.1016/0003-2670(92)85005-Q
- Toreci, I., Droste, R.L., Kennedy, K.J., 2011. Mesophilic anaerobic digestion with high-temperature microwave pretreatment and importance of inoculum acclimation. *Water Environ. Res.* 83, 549–559.
- Toreci, I., Droste, R.L., Kennedy, K.J., 2010. Microwave pretreatment for soluble phase mesophilic anaerobic digestion. *Environ. Prog. Sustain. Energy* 29, 242–248. doi:10.1002/ep
- Toreci, I., Kennedy, K.J., Droste, R.L., 2009. Effect of high temperature microwave thickened waste-activated sludge pretreatment on distribution and digestion of soluble organic matter. *Environ. Eng. Sci.* 26, 981–991. doi:10.1089/ees.2008.0297
- Tuan, N., Julcour-Lebigue, C., Barthe, L., Delmas, H., 2016. Optimisation of sludge pretreatment by low frequency sonication under pressure. *J. Environ. Manage.* 165, 206–212. doi:10.1016/j.jenvman.2015.09.015
- Uma Rani, R., Adish Kumar, S., Kaliappan, S., Yeom, I., Rajesh Banu, J., 2013. Impacts of microwave pretreatments on the semi-continuous anaerobic digestion of dairy waste activated sludge. *Waste Manag.* 33, 1119–1127. doi:10.1016/j.wasman.2013.01.016
- Uma Rani, R., Adish Kumar, S., Kaliappan, S., Yeom, I.T., Rajesh Banu, J., 2012. Low temperature thermo-chemical pretreatment of dairy waste activated sludge for anaerobic digestion process. *Bioresour. Technol.* 103, 415–424. doi:10.1016/j.biortech.2011.09.124
- Ushani, U., Kavitha, S., Johnson, M., Yeom, I.T., Banu, J.R., 2016. Upgrading the hydrolytic potential of immobilized bacterial pretreatment to boost biogas production. *Environ. Sci. Pollut. Res.* 1–14. doi:10.1007/s11356-016-7819-2
- Vaclavik, V., Christian, E.W., 2008. *Essentials of Food Science*. doi:10.1007/978-1-4757-5173-4
- Valo, A., Carrère, H., Delgenès, J.P., 2004. Thermal, chemical and thermo-chemical pre-treatment of waste activated sludge for anaerobic digestion. *J. Chem. Technol. Biotechnol.* 79, 1197–1203. doi:10.1002/jctb.1106
- Vavilin, V.A., Fernandez, B., Palatsi, J., Flotats, X., 2008. Hydrolysis kinetics in anaerobic degradation of particulate organic material: An overview. *Waste Manag.* 28, 939–951. doi:10.1016/j.wasman.2007.03.028
- Vergine, P., Záborská, J., Canziani, R., 2014. Low temperature microwave and conventional heating pre-treatments to improve sludge anaerobic biodegradability. *Water Sci. Technol.* 69, 518–24. doi:10.2166/wst.2013.735
- Vesilind, B.P.A., Martel, C.J., 1990. Freezing of water and wastewater sludges. *J. Environ. Eng.* 116, 854–862.
- Wahidunnabi, A.K., Eskicioglu, C., 2014. High pressure homogenization and two-phased anaerobic digestion for enhanced biogas conversion from municipal waste sludge. *Water Res.* 66, 430–446. doi:10.1016/j.watres.2014.08.045
- Wang, J., Li, Y., 2016. Synergistic pretreatment of waste activated sludge using CaO₂ in combination with microwave irradiation to enhance methane production during anaerobic digestion. *Appl. Energy* 183, 1123–1132. doi:10.1016/j.apenergy.2016.09.042
- Wang, L.-L., Wang, L.-F., Ren, X.-M., Ye, X.-D., Li, W.-W., Yuan, S.-J., Sun, M., Sheng, G.-P., Yu, H.-Q., Wang, X.-K., 2012. pH dependence of structure and surface properties of microbial EPS. *Environ. Sci. Technol.* 46, 737–744.
- Wang, Q., Fujisaki, K., Ohsumi, Y., Ogawa, H.I., 2001. Enhancement of dewaterability of thickened waste activated sludge by freezing and thawing treatment. *J. Env. Sci Heal. A Tox Hazard Subst Env. Eng*

- 36, 1361–1371. doi:10.1081/ESE-100104884
- Wang, Q., Jiang, G., Ye, L., Yuan, Z., 2014. Enhancing methane production from waste activated sludge using combined free nitrous acid and heat pre-treatment. *Water Res.* 63, 71–80. doi:10.1016/j.watres.2014.06.010
- Wang, Q., Liang, Y., Zhao, P., Li, Q.X., Guo, S., Chen, C., 2016. Potential and optimization of two-phase anaerobic digestion of oil refinery waste activated sludge and microbial community study. *Sci. Rep.* 6, 1–10. doi:10.1038/srep38245
- Wang, Q., Ye, L., Jiang, G., Jensen, P.D., Batstone, D.J., Yuan, Z., 2013. A novel free nitrous acid (FNA)-based technology for enhancing methane production from waste activated sludge. *Environ. Sci. Technol.* 47, 11897–11904.
- Wang, R., Liu, J., Lv, Y., Ye, X., 2016a. Sewage sludge disruption through sonication to improve the co-preparation of coal-sludge slurry fuel: the effects of sonic frequency. *Appl. Therm. Eng.* 99, 645–651. doi:http://dx.doi.org/10.1016/j.applthermaleng.2016.01.098
- Wang, R., Zhao, Z., Yin, Q., Liu, J., 2016b. Effects of the low-temperature thermo-alkaline method on the rheological properties of sludge. *J. Environ. Manage.* 177, 74–83. doi:10.1016/j.jenvman.2016.04.021
- Wang, Z., Cao, J., Meng, F., 2015. Interactions between protein-like and humic-like components in dissolved organic matter revealed by fluorescence quenching. *Water Res.* 68, 404–413. doi:10.1016/j.watres.2014.10.024
- Westerholm, M., Crauwels, S., van Geel, M., Dewil, R., Lievens, B., Appels, L., 2016. Microwave and ultrasound pre-treatments influence microbial community structure and digester performance in anaerobic digestion of waste activated sludge. *Appl. Microbiol. Biotechnol.* 1–14. doi:10.1007/s00253-016-7321-2
- Wett, B., Phothilangka, P., Eladawy, A., 2010. Systematic comparison of mechanical and thermal sludge disintegration technologies. *Waste Manag.* 30, 1057–1062. doi:10.1016/j.wasman.2009.12.011
- Wetzel, R.G., 1991. Extracellular enzymatic interactions: storage, redistribution and interspecific communication, in: *Microbial Enzymes in Aquatic Environments*. Springer Berlin Heidelberg, p. 6.
- Wilén, B.M., Jin, B., Lant, P., 2003. The influence of key chemical constituents in activated sludge on surface and flocculating properties. *Water Res.* 37, 2127–2139. doi:10.1016/S0043-1354(02)00629-2
- Wilson, C.A., Novak, J.T., 2009. Hydrolysis of macromolecular components of primary and secondary wastewater sludge by thermal hydrolytic pretreatment. *Water Res.* 43, 4489–4498. doi:10.1016/j.watres.2009.07.022
- Wingender, J., Neu, T.R., Flemming, H.-C., 1999. What are bacterial extracellular polymeric substances?, in: *Microbial Extracellular Polymeric Substances*. Springer, pp. 1–19.
- Wu, J., Yang, Q., Luo, W., Sun, J., Xu, Q., Chen, F., Zhao, J., Yi, K., Wang, X., Wang, D., Li, X., Zeng, G., 2018. Role of free nitrous acid in the pretreatment of waste activated sludge: Extracellular polymeric substances disruption or cells lysis? *Chem. Eng. J.* 336, 28–37. doi:10.1016/j.cej.2017.11.038
- Wu, L.-J., Higashimori, A., Qin, Y., Hojo, T., Kubota, K., Li, Y.-Y., 2016. Upgrading of mesophilic anaerobic digestion of waste activated sludge by thermophilic pre-fermentation and recycle: Process performance and microbial community analysis. *Fuel* 169, 7–14. doi:10.1016/j.fuel.2015.11.091
- Xiao, B., Liu, C., Liu, J., Guo, X., 2015. Evaluation of the microbial cell structure damages in alkaline pretreatment of waste activated sludge. *Bioresour. Technol.* 196, 109–115. doi:10.1016/j.biortech.2015.07.056
- Xiao, B., Liu, J., 2006. Effects of thermally pretreated temperature on bio-hydrogen production from sewage sludge. *J. Environ. Sci.* doi:10.1007/s11434-009-0100-z
- Xu, G., Chen, S., Shi, J., Wang, S., Zhu, G., 2010. Combination treatment of ultrasound and ozone for

- improving solubilization and anaerobic biodegradability of waste activated sludge. *J. Hazard. Mater.* 180, 340–346. doi:10.1016/j.jhazmat.2010.04.036
- Yang, S.S., Guo, W.Q., Meng, Z.H., Zhou, X.J., Feng, X.C., Zheng, H.S., Liu, B., Ren, N.Q., Cui, Y.S., 2013. Characterizing the fluorescent products of waste activated sludge in dissolved organic matter following ultrasound assisted ozone pretreatments. *Bioresour. Technol.* 131, 560–563. doi:10.1016/j.biortech.2013.01.024
- Yeneneh, A.M., Chong, S., Sen, T.K., Ang, H.M., Kayaalp, A., 2013. Effect of ultrasonic, microwave and combined microwave-ultrasonic pretreatment of municipal sludge on anaerobic digester performance. *Water. Air. Soil Pollut.* 224. doi:10.1007/s11270-013-1559-4
- Yi, W.G., Lo, K.V., Mavinic, D.S., 2014. Effects of microwave, ultrasonic and enzymatic treatment on chemical and physical properties of waste-activated sludge. *J. Env. Sci Heal. A Tox Hazard Subst Env. Eng* 49, 203–209. doi:10.1080/10934529.2013.838880
- Yu, J., Zheng, M., Tao, T., Zuo, J., Wang, K., 2013. Waste activated sludge treatment based on temperature staged and biologically phased anaerobic digestion system. *J. Environ. Sci.* 25, 2056–2064. doi:10.1016/S1001-0742(12)60266-6
- Yu, S., Zhang, G., Li, J., Zhao, Z., Kang, X., 2013. Effect of endogenous hydrolytic enzymes pretreatment on the anaerobic digestion of sludge. *Bioresour. Technol.* 146, 758–761. doi:10.1016/j.biortech.2013.07.087
- Yu, Z., Johnston, K.P., Williams, R.O., 2006. Spray freezing into liquid versus spray-freeze drying: Influence of atomization on protein aggregation and biological activity. *Eur. J. Pharm. Sci.* 27, 9–18. doi:10.1016/j.ejps.2005.08.010
- Zahedi, S., Icaran, P., Yuan, Z., Pijuan, M., 2016. Assessment of free nitrous acid pre-treatment on a mixture of primary sludge and waste activated sludge: Effect of exposure time and concentration. *Bioresour. Technol.* 216, 870–875. doi:10.1016/j.biortech.2016.06.038
- Zahedifar, M., Castro, F.B., Ørskov, E.R., 2002. Effect of hydrolytic lignin on formation of protein-lignin complexes and protein degradation by rumen microbes. *Anim. Feed Sci. Technol.* 95, 83–92. doi:10.1016/S0377-8401(01)00305-4
- Zahmatkesh, M., Spanjers, H., Toran, M., Blázquez, P., van Lier, J.B., 2016. Bioremoval of humic acid from water by white rot fungi: exploring the removal mechanisms. *AMB Express* 6 (1). doi:10.1186/s13568-016-0293-x
- Zhang, T., Fang, H.H.P., 2001. Quantification of extracellular polymeric substances in biofilms by confocal laser scanning microscopy. *Biotechnol. Lett.* 23, 405–409. doi:10.1023/A:1005620730265
- Zhang, T., Wang, Q., Ye, L., Batstone, D., Yuan, Z., 2015. Combined free nitrous acid and hydrogen peroxide pre-treatment of waste activated sludge enhances methane production via organic molecule breakdown. *Sci. Rep.* 5, 16631. doi:10.1038/srep16631
- Zhang, W., Yang, P., Yang, X., Chen, Z., Wang, D., 2015. Insights into the respective role of acidification and oxidation for enhancing anaerobic digested sludge dewatering performance with Fenton process. *Bioresour. Technol.* 181, 247–253. doi:10.1016/j.biortech.2015.01.003
- Zhang, X., Spanjers, H., van Lier, J.B., 2013. Potentials and limitations of biomethane and phosphorus recovery from sludges of brackish/marine aquaculture recirculation systems: A review. *J. Environ. Manage.* 131, 44–54. doi:10.1016/j.jenvman.2013.09.016
- Zhang, Y., Zhang, P., Ma, B., Wu, H., Zhang, S., Xu, X., 2012. Sewage sludge disintegration by high-pressure homogenization: A sludge disintegration model. *J. Environ. Sci.* 24, 814–820. doi:10.1016/S1001-0742(11)60834-6
- Zhen, G., Lu, X., Li, Y.Y., Zhao, Y., 2014. Combined electrical-alkali pretreatment to increase the anaerobic hydrolysis rate of waste activated sludge during anaerobic digestion. *Appl. Energy* 128, 93–102. doi:10.1016/j.apenergy.2014.04.062
- Zhen, G., Lu, X., Wang, B., Zhao, Y., Chai, X., Niu, D., Zhao, A., Li, Y., Song, Y., Cao, X., 2012. Synergetic

- pretreatment of waste activated sludge by Fe(II)-activated persulfate oxidation under mild temperature for enhanced dewaterability. *Bioresour. Technol.* 124, 29–36.
doi:10.1016/j.biortech.2012.08.039
- Zhou, A., Yang, C., Guo, Z., Hou, Y., Liu, W., Wang, A., 2013. Volatile fatty acids accumulation and rhamnolipid generation in situ from waste activated sludge fermentation stimulated by external rhamnolipid addition. *Biochem. Eng. J.* 77, 240–245. doi:10.1016/j.bej.2013.06.007
- Zhou, X., Wang, Q., Jiang, G., 2015. Enhancing methane production from waste activated sludge using a novel indigenous iron activated peroxidation pre-treatment process. *Bioresour. Technol.* 182, 267–271. doi:10.1016/j.biortech.2015.01.132
- Zielewicz, E., 2016. Effects of ultrasonic disintegration of excess sewage sludge. *Appl. Acoust.* 103, 182–189. doi:10.1016/j.apacoust.2015.05.007
- Zorba, G.T., Sanin, F.D., 2013. Disintegration of sludge by sonication and improvement of methane production rates in batch anaerobic digesters. *Clean soil, air, water* 41, 396–402.
doi:10.1002/clen.201100391

Chapter 3. *Vidi*: Effects of low-temperature thermal pre-treatment combined with H₂O₂ on the bioconversion of WAS to methane.

This chapter is originally published as:

Gonzalez, A., Guo, H., Ortega-Ibáñez, O., Petri, C., van Lier, J.B., de Kreuk, M., Hendriks, A., 2020. Mild thermal pre-treatment of waste activated sludge to increase loading capacity, biogas production, and solids' degradation: A pilot-scale study. *Energies* 13, 6059. <https://doi.org/10.3390/en13226059>.

Abstract

Sludge pre-treatments are emerging as part of the disposal process of solid by-products of wastewater purification. One of their benefits is the increase in methane production rate and/or yield, along with higher loading capacities of existing digesters. In this study, we report the performance of a pilot-scale compartmentalized digester (volume of 18.6 m³) that utilized a mild thermal pre-treatment at 70 °C coupled with hydrogen peroxide dosing. Compared to a reference conventional anaerobic digester, this technique allowed an increased organic loading rate from 1.4 to 4.2 kg VS /m³d and an increment in the solids degradation from 40 to 44%. To some extent, these improvements were promoted by the solubilization of the tightly-bound fraction of the extracellular polymeric substances to looser and more accessible fractions without the formation of refractory compounds. In sum, our results suggest that this pre-treatment method could increase the treatment capacity of existing digesters without significant retrofitting.

Keywords: hydrogen peroxide; mild-temperature; pilot-scale; thermal pre-treatment; thermochemical pre-treatment; waste activated sludge.

3.1 Introduction

Population growth and increase in the coverage of sanitation are factors that increase the volume of waste activated sludge (WAS) to be treated. Anaerobic digestion is a common approach to reduce the organic sludge mass; however, the low hydrolysis rate (k_{hyd}) of WAS results into the need for long retention times and large reactor volumes. This is particularly problematic when an existing plant, without possibility for expansion, is faced with an increased volume of WAS to be treated.

Consequently, WAS pre-treatments have emerged with advantages such as increased COD solubilization and biodegradation, among others (Carrère et al., 2010; Neumann et al., 2016). Application of pre-treatments with low consumption of energy as well as the avoidance of sophisticated and complex processes are desirable, in order to increase energy recovery from sludge processing, while additional expenses on investment and maintenance remain low. In this regard, mild-temperature pre-treatment coupled with hydrogen peroxide dosing in combination with compartmentalized digestion seems a low-cost approach with potentially positive outcomes (Bhattacharya et al., 1996; Cacho Rivero and Suidan, 2006; Jung et al., 2014; Maspolim et al., 2015).

Thermal pre-treatment at temperatures below 100 °C utilizes less energy compared to pre-treatment at higher temperatures and pressures (Gonzalez et al., 2018). The required energy can be supplied in the form of waste heat and does not require pressurized vessels. Moreover, low-temperature pre-treatment can be improved via the addition of hydrogen peroxide: Jung and co-workers documented that pre-treatment at 60 °C together with 362 mg H₂O₂/g total solids (TS) achieved a 10 % increase in biogas production compared to standalone thermal pre-treatment (Jung et al., 2014). Similarly, Cacho Rivero and Suidan observed that a pre-treatment at 90 °C, applying between 0-412 mg H₂O₂/g total suspended solids (TSS) increased volatile suspended solids (VSS) degradation from 46 to 71.6 % (Cacho Rivero and Suidan, 2006). Finally, Özön and Erdinçler reported an absolute increase in biodegradation of 9 % at 75 °C and 1000 mg H₂O₂/g TS compared to the control sample (Özön and Erdinçler, 2019). These studies were performed at laboratory scale.

Compartmentalized digestion, i.e., staging of anaerobic digestion using the same temperature but subjected to different pH values in separated compartments, has also been applied with positive results. For instance, Maspolim and colleagues studied two-staged mesophilic digestion with pH values of 5.5 and 7.0 for the first and second compartment, respectively (Maspolim et al., 2015). Their system was able to maintain a stable methane production and volatile solids (VS) degradation after an increase in organic loading rate (OLR) from 2.2 to 3.5 kg COD/m³d, equivalent to 1.3-2.1 kg VS/m³d. In contrast, under the same settings, the single-staged reactor delivered a diminished performance in both biogas and degradation of solids. Similarly, Bhattacharya et al used a two-stage configuration to digest a mixture of primary and secondary sludge with a hydraulic retention time (HRT) of 2.7 d for the first reactor and 10 d for the second one (Bhattacharya et al., 1996). Their reactor achieved a 6 % absolute increase in VS degradation compared to one-stage digestion at the same HRT. The reasons for the observed improvements in phased digestion have been associated with the optimization of environmental conditions for hydrolytic/fermentative bacteria in terms of pH, retention time, and loading rate (Bhattacharya et al., 1996; Lv et al., 2010; Maspolim et al., 2015).

It is well-known that hydrolysis is the rate-limiting step in particulate substrate degradation such as excess sewage sludge. In this study we examined to what extent mild thermal pre-treatment provoked an increase in the WAS hydrolysis rate, which in turn allowed a substantial increase in applicable OLR in

a compartmentalized digester, combining the advantages of the two treatment approaches. In addition, the impact of H₂O₂ dose during mild temperature pre-treatment was evaluated at lab-scale. Finally, pros and cons of this process amendment are discussed as well as possible mechanisms underlying the proposed pre-treatment technique.

3.2 Materials and Methods

3.2.1 Substrate, inoculum and pre-treatment

Secondary sludge with a TS concentration of 5-6% from wastewater treatment plant (WWTP) Nieuwgraaf (Arnhem, The Netherlands) was used for lab-scale experiments. Digestate from the anaerobic digesters, operated at an HRT of 21 days and 37 °C, was incubated for about one week, after which it was filtered with a 1 mm-sieve and used as inoculum. Temperatures of 60, 70 and 80 °C were applied to the secondary sludge, as well as exposure times of 20, 30 or 240 minutes. Afterwards, 0-250 mg H₂O₂/g TS of a 30% solution (Carl Roth, Germany) were applied to the warm sludge and the sample was mixed until temperature decreased to 35 °C. The pilot-scale reactors were fed with a blend of primary and secondary sludge in a mass ratio of 25:75. Only the secondary sludge was subjected to thermal pre-treatment, and the temperature, peroxide dose and exposure time were 70 °C, 15 mg H₂O₂/g TS, and 30 minutes, respectively.

3.2.2 Anaerobic digestion

During all lab-scale experiments, the cumulative methane production (CMP) assays were performed in triplicate, using an AMPTS-2 (BioProcess Control, Sweden). Bottles with a capacity of 500-mL were filled with 400 mL of a mixture of inoculum and substrate in a ratio of 2 on VS basis. Hereafter, phosphate buffer and nutrient solutions were added, as described by (Zhang et al., 2014) and the bottles were sealed and flushed with a blend of 80% Nitrogen and 20% CO₂ by volume, until the free space was replaced at least 5 times to displace oxygen in the headspace. Afterwards, a mixing motor was coupled to each bottle, which were incubated at 35 °C. The produced biogas was directed to a 3 M NaOH scrubber solution that adsorbs CO₂ and the flow of methane was then quantified via a calibrated cell, which produces an electrical signal every ~10 N mL of gas.

The pilot-scale set-up consisted of two treatment lines (Figure 3.1): a reference digester consisting of a single stage reactor (volume of 13.7 m³) and a compartmentalized digester composed of two staged reactors of 9.3 m³ each. During the pilot-scale experiment, biogas was measured via a gas-flow meter Model Proline Prosonic Flow B 200 (Endress and Hauser, Switzerland). This device is also able to quantify the methane content of biogas. Each compartment was equipped with one meter. The working volume of the pilot reactors fluctuated following the applied OLR. The compartmentalized digester had a minor recirculation from the second to the first compartment, which was adjusted based on the pH in the first digester.

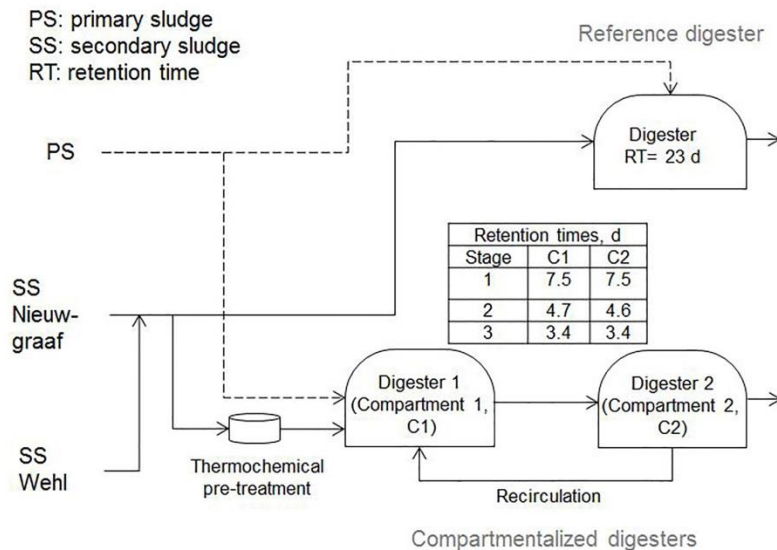

Figure 3.1 Scheme of the pilot-scale test.

3.2.3 Analytical methods

TS and VS were quantified according to standard methods 2540B and 2540E (APHA et al., 2017). For the determination of chemical oxygen demand (COD), the open reflux method (5220B) was used. The soluble fraction (sCOD) was obtained by centrifuging the sample at 15,000 g for 10 minutes and filtering the supernatant through a polytetrafluoroethylene filter (PTFE) (Macherey-Nagel GmbH & Co, Düren, Germany) with a nominal pore-size of 0.45 μm .

E. coli determination was performed via pour plate method 9215B (APHA et al., 2017), by means of Compact Dry EC (Nissui Pharmaceutical Co., Japan). Dilutions were in the range of 10^1 to 10^3 for pre-treated samples and up to 10^5 for raw sludge. The water for dilution was sterile saline solution of 0.9 % NaCl.

Volatile fatty acids (VFAs) were measured using the procedure of (Ghasimi et al., 2016b). Samples of digestate were centrifuged at 14,500 rpm for 5 minutes and the supernatant was filtered with the PTFE filter mentioned above and diluted by a factor of 2 using a 320 mg/L solution of 1-pentanol as solvent and 10 μm of 98% formic acid. The working volume of the vial was 1.5 mL.

Extracellular polymeric substances (EPS) were extracted based on the method proposed by (Liu et al., 2016). Ca^{2+} , Mg^{2+} , Na^+ , and K^+ were determined using an ion-chromatograph 883 cation system (Metrohm AG, Switzerland) equipped with a metrosep C 4 - 150/4 column (Metrohm AG, Switzerland). The used eluent was 3 mM HNO_3 at a flow rate of 0.9 mL/min.

Microbial composition analyses were performed using DNA extractions, taking duplicate samples of 0.5 g from the liquors of both the reference and compartmentalized digesters. DNA was extracted with a FastDNA™ SPIN Kit for Soil (MP Biomedicals, USA), while its quality and quantity were evaluated by a Qubit3.0 DNA detection kit (Qubit® dsDNA HS Assay Kit, Life Technologies, U.S.). High throughput sequencing was performed by the HiSeq Illumina platform with universal primer 515F/806R for bacterial and archaeal 16S rRNA genes (Novogene, Cambridge, UK). Finally, sequences were further analyzed by the QIIME pipelines (version 1.7.0) (Caporaso et al., 2010) to pair forward and reverse sequences, and

chimeras were removed by the UCHIME algorithm (Edgar et al., 2011). Sequences with $\geq 97\%$ similarity were clustered into one operational taxonomic unit (OTUs) by UCLUST algorithm (Edgar, 2010). Singletons were removed and OTUs with an occurrence less than three times in at least one sample were excluded. Taxonomic assignment was performed in Mothur software against the SILVA Database. The variation in relative abundance of Bacteria at the phylum level and that of Archaea at the genus level was plotted with MS Excel.

Dewaterability was assessed by measuring the capillary suction time (CST) according to method 2710G (APHA et al., 2017) using a CST type 304M (Triton Electronics Ltd., England) and chromatography paper manufactured by the same company. Press-filter assays were performed with a Mareco Minipress MMP3 (Afmitech, The Netherlands). The used conditioning agent (polymer) was Superfloc C-82090 (Kemira, Finland), the same as the one used in the full-scale process. Different doses were assayed until optima were found for each system. Firstly, the amount of polymer corresponding to the specified dose was applied to the digestate in a flocculator (Velp Scientifica, Italy) at two mixing regimes: 15 s at 250 rpm and 1 min at 22 rpm until a lump of sludge was formed. Secondly, 250 mL of the resulting suspension was added to the working cell of the press-filter. The pneumatic pressure was 6 bar with a disc-pressing speed of ~ 5 mm/min. Finally, a pilot-scale centrifuge model UCD 205-00-32 (GEA Group, Germany) with a set rotational speed of 3600 rpm and a maximum flow of $5 \text{ m}^3/\text{h}$ was used for comparison.

3.2.4 Biodegradation and methane production rate

Sludge biodegradation (β) was calculated according to Equation 3.1, β_0 corresponded to the amount of methane produced during the digestion divided by the theoretical production of methane from one gram of substrate COD. For simplicity, the COD required for cell maintenance and synthesis was not considered. Methane production rate (k_{CH_4}) was calculated based on methane production under the assumption of following a first-order kinetics (Wang et al., 2013), using a two-substrate kinetic model as given in Equation 3.2. The division between $k_{CH_4\text{-rapid}}$ and $k_{CH_4\text{-slow}}$ was set based on the visual examination of the slopes of methane production curve, which occurred between day 3 and 4.

$$\beta_0 (\%) = 100 \times \frac{\text{Measured Methane production} \left(\text{ml} \frac{\text{CH}_4}{\text{gCOD}_{\text{added}}} \right)}{350 \text{ ml} \frac{\text{CH}_4}{\text{gCOD}_{\text{added}}}} \quad (\text{Eq. 3.1})$$

$$B = B_{0,\text{rapid}}(1 - e^{-k_{CH_4\text{-rapid}} t}) + B_{0,\text{slow}}(1 - e^{-k_{CH_4\text{-slow}} t}) \quad (\text{Eq. 3.2})$$

3.2.5 Design of experiments and statistical analyses

The lab-scale phase followed a full-factorial design of experiments. Either one or two-way ANOVA was used to assess the effect of pre-treatment temperature and exposure time by means of Origin Pro 9 (Origin Lab Corp, USA). Standard deviation was used as a measurement of experimental error.

For the pilot-scale experiment, various statistical tools and techniques were applied to identify differences between the two reactors. Firstly, histograms were plotted to examine the data distribution and to define proper statistical hypotheses and models to be applied. A Shapiro-Wilks test was used to assess the normality of the data sets. Secondly, a Wilcoxon signed rank test (the non-parametric equivalent of the Student's t-test) was applied. Finally, the statistics associated with the Wilcoxon test

(*W*) and its *p*-value were calculated to assess statistical significance between the studied digesters. The analysis of data was performed with the statistical software R: A language and environment for statistical computing (R Foundation for Statistical Computing, Austria). Linear adjustments were obtained with a linear regression model in MS Excel. Statistical analyses for both the lab and pilot scale considered a 95% confidence level ($\alpha = 0.05$).

3.3 Results and discussion

3.3.1 Lab-scale experiments

The effects of pre-treatment temperature, exposure time and peroxide dose on biodegradation, k_{CH_4} , sCOD, *E.coli*, CST and VS degradation were studied in a series of three batch experiments. In experiment #1 we investigated the effect of temperature, i.e., 60, 70 and 80 °C, and holding times, i.e., 20, 30 and 240 minutes, with a peroxide dose of 10 mg/gTS for all samples. The combination that resulted into the highest methane production extend was implemented in experiment #2, at peroxide doses of 0, 5, 10 and 15 mg H₂O₂/gTS. Finally, the same temperature and exposure time combination was applied in experiment #3, using peroxide doses of 15, 30, 50, 100 and 250 mg H₂O₂/gTS. Overall, the experimental design allowed a comparison of the effects of temperature, exposure time and H₂O₂ dose (Table 3.1). A discussion of the relevant findings is presented below.

3.3.1.1 Effects of temperature and time

Despite a notorious COD solubilization (Figure S3-1), the pre-treatment at 60 °C had a similar methane production compared to the non-heated sample (named as reference in Figure 3.2a). Pre-treatment conditions at 70 °C during 30 minutes revealed the highest yield in terms of cumulative methane production, while COD solubilization was found to be highest at 80 °C during 240 minutes. However, pre-treatment at 80 °C did not show any considerable difference in methane production compared to 60 °C pre-treatment and the non-heated sample. Also, the residual sCOD after 30 days of digestion was highest for 80 °C pre-treatment, with an increasing trend at increased heating time (Figure 3.2b and Table 3.1). No VFA analyses were conducted during digestion in this stage of the study. However, the absence of a sigmoidal shape in any of the cumulative methane production curves (Figure S3-2) suggest that methanogenesis was not the rate limiting step. Moreover, the overall VS degradation for the 80 °C pre-treatment was lower than for the lower temperatures (Table 3.1). Thus, it was assumed that about one-third of the solubilized COD during pre-treatment at 80 °C was recalcitrant, in contrast to the other temperatures that degraded almost all of the solubilized COD.

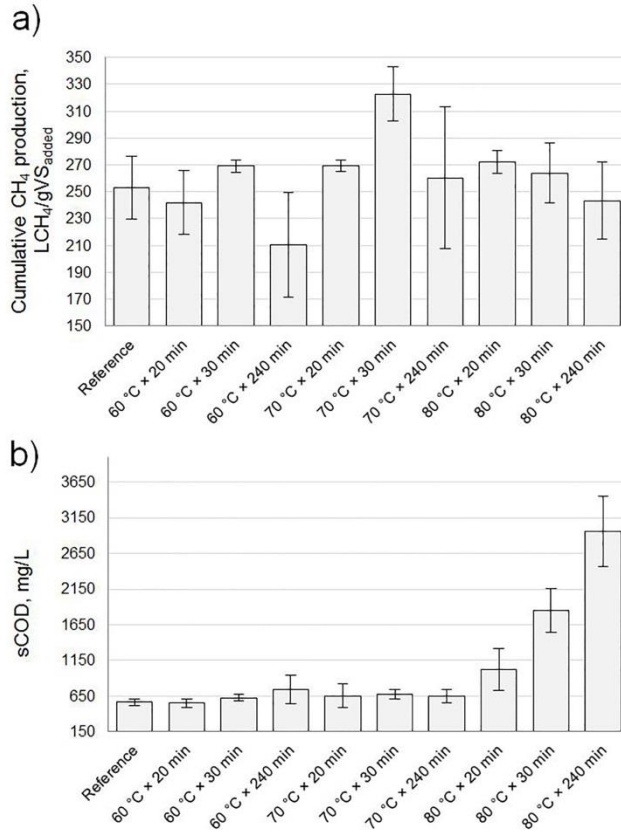

Figure 3.2 (a) Cumulative methane production for the assayed conditions; (b) sCOD of the digestates after 30 days of digestion. Note: all conditions (including reference) included 10 mg H₂O₂/g TS.

Regarding the duration of pre-treatment, an exposure time of 240 min produced less methane compared to shorter times at any temperature. This finding agrees with previous studies showing that temperature and exposure time have a combined effect on biogas production under similar conditions to the ones in this research (Appels et al., 2010; Hiraoka et al., 1985; Hosseini Koupaie et al., 2017).

Apparently, during pre-treatment, only the digestible fraction of the COD was solubilized, which may explain the observed rise in hydrolysis rate found by (Liao et al., 2016) at 60 °C. Methane production rates reflecting solids hydrolysis were determined only for the reference and WAS pre-treated at a temperature of 70 °C (Figure 3.3) and (Table S3-1). The combination of 70 °C and 5-15 mg H₂O₂/gTS resulted in an increase in $k_{CH4-rapid}$, while $k_{CH4-slow}$ was unaffected by pre-treatment (Figure 3.3). In contrast, the application of hydrogen peroxide to non-thermally treated WAS resulted into a decrease in $k_{CH4-rapid}$, probably because of the oxidative stress caused by peroxide reaching anaerobic digestion. This finding suggests that the exposure to a specific temperature is pivotal for applying H₂O₂ during the pre-treatment and to prevent H₂O₂ entering the anaerobic digesters.

The observed increase in $k_{CH4-rapid}$ could have originated from possible production of VFAs during pre-treatment. To verify this, a sample of activated sludge was pre-treated at 70 °C with 15 mgH₂O₂/gTS. The results, shown in Figure S3-3, demonstrated that the concentration of VFAs during pre-treatment was below 30 mg/L. On the other hand, the VFA concentrations during digestion of a sludge sample that was similarly pre-treated accumulated to values between 100 and 500 mg/L. The disparity between the VFA

concentrations during pre-treatment and digestion clearly shows that the solubilized COD produced during pre-treatment was only very limitedly composed of VFAs.

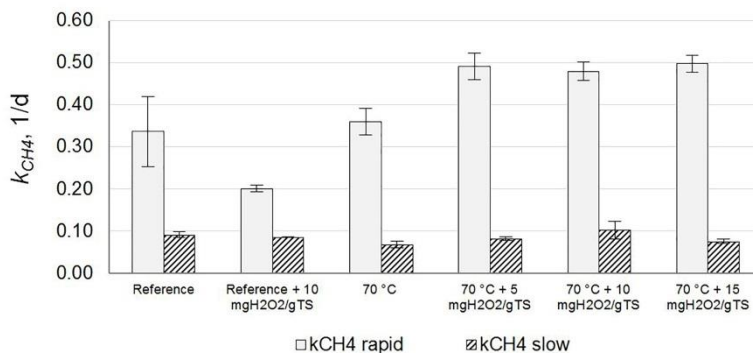

Figure 3.3. Methane production rates following pre-treatments during experiment #2, at an exposure time of 30 minutes. n=3 except for Reference + 10 mg H₂O₂/gTS, which had n=2.

CST was measured as a proxy for dewaterability of the digestate. Compared to the reference, a pre-treatment temperature of 80 °C produced digestates with lower CSTs, indicating an improvement in dewaterability (Figure S3-4). On the other hand, temperatures of 60 °C and 70 °C resulted in CST times similar to the control sample. These results partially agree with those of Eskicioglu et al (2008), who did not find any changes in CST after exposing WAS to 60 and 80 °C, compared to the untreated sample. On the other hand, Laurent and colleagues observed a reduction in average particle size from 118 μm to 82 μm for a pre-treatment temperature of 75 °C and 120 min of exposure time (Laurent et al., 2009a). It is inferred that small particles increase the surface area for water bonding, and thus will negatively affect the dewaterability (Mowla et al., 2013). In our present study, the particle size distribution was not measured.

The concentration of *E. coli* was measured to assess hygienization of the pre-treated sludge. Figure S3-5 shows that *E. coli* declined proportionally to temperature and treatment time. At the harshest pre-treatment combination (80 °C and 240 min) their content fell below detection level in the treated sample. After digestion, *E. coli* were detected even in higher concentrations compared to the untreated sample (Figure S3-6). Since the batch digesters were inoculated with digestate, residual *E. coli* could have derived from either the substrate or the inoculum. Apparently, digester conditions, *i.e.* abundant presence of nutrients and trace elements that are released during pre-treatment or digestion, are suitable for further manifestation or even possible growth of *E. Coli*. (Fu et al., 2014; Higgins et al., 2007).

Table 3.1. Effects of the studied variables related to applied temperature, H₂O₂ dose, and exposure time.

Parameter	Studied variables		
	Temperature	Peroxide dose	Exposure time
Cumulative methane production	-60 °C produced less CH ₄ than 70 and 80 °C (p=0.0115).	-No effect at 0 and 15 mg H ₂ O ₂ /gTS (p=0.5458)	-240 min produced less CH ₄ (p=0.0066)
	-70 °C produced more CH ₄ compared to the reference (20 °C) (p=0.0000)	-At 70°C, the higher the dose of H ₂ O ₂ (0-250 mg/gTS), the lower the methane production (p=0.0188)	

COD solubilization in pre-treated sample	-Proportional increase in sCOD from 60 to 80 °C (p=0.0000)	-No effect at 70 °C, with doses from 0-15 mg H ₂ O ₂ /gTS (p=0.5732)	-Proportional increase in sCOD from 20 to 240 minutes (p=0.0000)
sCOD after digestion (sCOD in digestate)	-80 °C had three-fold sCOD than other temperatures (p=0.0000)	-Not determined	-Proportional increase in sCOD from 20 to 240 minutes (p=0.0000)
Methane production rate, <i>k_{CH4}</i>	- Addition of 10 mg H ₂ O ₂ /gTS (without thermal pre-treatment) lowered <i>k_{CH4-rapid}</i> , from 0.34 to 0.20 d ⁻¹	-At 70°C and addition of 5-15 H ₂ O ₂ /gTS increased <i>k_{CH4-rapid}</i> to 0.49 d ⁻¹ vs reference (0.34 d ⁻¹)	-Not determined
VS degradation	-80 °C achieved less VS degradation compared to 70 and 60 °C (p=0.0003) -70 °C achieved 54.1 ± 6.4 % VS degradation compared to the reference (32.2 ± 8.47 %), p=0.0338 -60°C remained similar to the reference	-No effect at 15 mg H ₂ O ₂ /gTS (p=0.6850)	-Not determined
CST	-Shorter CST for 80 °C (p=0.0000)	-Not determined	-Not determined
<i>E. Coli</i> concentration in substrate at the beginning of digestion	-Proportional reduction in the range 60-80 °C (p=0.0000)	-Not determined	-Higher reduction at 240 minutes (p=0.0316)
<i>E. Coli</i> in the sludge mixture at the end of digestion	-Higher concentration at 70 °C compared to reference (p=0.0051)	-15 mg H ₂ O ₂ /gTS increased <i>E. coli</i> at 70 °C (p=0.0004) -No effect of adding 15 mg H ₂ O ₂ /gTS compared to the reference (p=0.07339)	-Not determined

3.3.1.2 Effects of peroxide

The addition of H₂O₂ at concentrations ≤ 15 mg /g TS did not increase either methane production or sCOD nor affected the concentration of *E. coli*. Results showed that a positive effect of the addition of peroxide was evident only when it was accompanied by thermal pre-treatment at 70 °C as it increased the methane production rate from 0.34 to 0.49 d⁻¹ (Table 3.1). The assessed *k_{CH4}* reflected the solids hydrolysis rate, which is related to the particle size of the substrate (Sanders et al., 2000; Vavilin et al., 2008). Therefore, an increase in *k_{CH4}* with the addition of H₂O₂ likely can be ascribed to a reduction in particle size. A previous study demonstrated that the addition of 20 mg H₂O₂/gTS at 90 °C triggered a decrease in the particle size of treated sludge compared to the sole application of thermal pre-treatment (Lo et al., 2017). Alternatively, a Fenton mechanism may have played a role in the increased degradation rates: Fenton chemistry is related to the utilization of peroxide for the formation of reactive oxidative species (particularly hydroxyl radicals) under the presence of ferrous iron as catalyst (Lo et al., 2017; Özön and Erdinçler, 2019). Although not very likely in our current experimental set-up, a Fenton reaction might have occurred in the batch assays for two reasons. Firstly, catalase –the enzyme that

decomposes H_2O_2 into water and molecular oxygen –denaturizes at temperatures higher than 60 °C (Guwy et al., 1999; Nadler et al., 1986), preventing peroxide to be scavenged in the WAS matrix after pre-treatment. Secondly, the remaining H_2O_2 molecules in WAS might have reacted with iron species or other transition metal catalysts during heating, which could have produced hydroxyl radicals. However, for an efficient Fenton reaction iron should remain in solution, for which a $\text{pH}<4$ is optimal (Bokare and Choi, 2014; Garrido-Ramírez et al., 2010). However, during the pre-treatment, the pH of sludge fluctuated between 6.0 to 6.5 (Figure S3-3).

3.3.1.3 Reproducibility

The assays of cumulative methane production were performed with WAS and anaerobic digestate samples taken at different moments in a time span of three months. The results revealed limited reproducibility of the specific methane productions of the untreated samples (see Figure S3-7, flask R1, R2 and R3). In addition, the WAS responded substantially different to pre-treatment (Figure S3-2, flask E and M; and N and Q), with absolute variations in biodegradation (β_0) ranging from 11% to 29% at the same pre-treatment conditions. The differences in specific methane production of the control samples could be a consequence of the fluctuating seasonal composition of the WAS (Ruffino et al., 2019a), which could also have influenced the pre-treatment results (Dai et al., 2017a; Xu et al., 2017). Therefore, a detailed characterization of the substrate is relevant for a meaningful comparison between studies.

3.3.2 Pilot-scale experiments

The best settings of the pre-treatment method were applied in the pilot-scale experiment with the objective to markedly increase the OLR, VS degradation and biogas production. To fulfil this goal, a combination of mild thermal pre-treatment methods with peroxide dosing and the more proven compartmentalized anaerobic digestion was chosen. The applied pre-treatment settings were adopted from the batch test: a temperature of 70 °C, an exposure time of 30 minutes and the addition of 15 mg $\text{H}_2\text{O}_2/\text{g TS}$. The OLR was the independent variable, whereas biogas production and the degradation of organics were the response variables. The test consisted of three stages: for stage #1, the single stage reference reactor had an OLR of 1.4 kg VS/ m^3d (2.1 kg COD/ m^3d) corresponding to a retention time of 23 days, a typical value for anaerobic digestion of WAS. The OLR and retention time of the compartmentalized reactor were 4.2 kg VS/ m^3d (5.8 kg COD/ m^3d) and 15 days. The collection of data started after at least three retention times for attaining a stabilized condition after the previous feeding regime. In addition, during days 30 to 49 the reactor was being adapted for the conditions of the next stage (transition period) and thus, those data were excluded for statistical analyses. During stages #2 and #3, the compartmentalized reactor was tested to examine its ability to withstand peak loads of 6.5 and 10 kg VS/ m^3d , while the reference reactor was stopped. The duration of these peak load experiments was 23 and 7 days, respectively. Outcomes of these pilot tests are discussed below.

3.3.2.1 Stage #1

Figure 3.4 shows the sets of data of biogas production and VS degradation for both reactors, whereas Table 3.2 presents the average values obtained along the test. The spreading of data complicates differentiation between the two reactors, as it is observed from the histograms in Figure S3-8. The Shapiro-Wilks normality test showed that the assumption of normality was not accomplished for the reference reactor ($p\text{-value}=0.0191$). This is also shown in the slight bias to the left side of the histogram in Figure S3-8. On the other hand, the dataset of the compartmentalized reactor can be considered

extracted from a normal distribution (p -value=0.1540), despite the absence of symmetry around the mean. As at least one of the reactors did not comply with the assumption of normality, the non-parametric Wilcoxon signed rank test was applied to assess differences between the two processes. The application of such a test requires the fulfilment of four assumptions (Meek et al., 2007), which were evaluated in Table S3-2. The Wilcoxon signed rank test indicated that there was a significant difference in biogas production between the two reactors ($W=321$; p -value=0.0011). In other words, the compartmentalized reactor produced around 15% more biogas compared to the reference (Table 3.2).

The resulting linear regression curves obtained from biogas production data (Figure 4a) show a positive slope, suggesting that both reactors were not fully stable during the experiment and were likely still adapting to the substrate. During stage #1, the compartmentalized reactor generated around 85% of the biogas in the first compartment (i.e., during the first 7 days of digestion) (Figure S3-9), coinciding with the lab-scale observation on the increase in k_{CH_4} (Figure 3.3) and Table S3-1.

In line with the results of biogas production, the histograms for VS degradation are shown in Figure S3-11. The Shapiro-Wilks normality test results showed that the compartmentalized reactor did not have a normal data distribution (p -value=0.0058). The Wilcoxon test was applied and resulted in a significant difference between the reference and the compartmentalized reactor for VS degradation ($W=281$; p -value=0.0227), which represents an increase of 5% in absolute VS degradation (Table 3.2).

Finally, during stage #1, VFA analyses were performed three times, showing that their concentration was below 10 mg/L for both reactors (Table 3.2), suggesting the absence of substantial VFA accumulation and hydrolysis being the rate limiting step in stage #1.

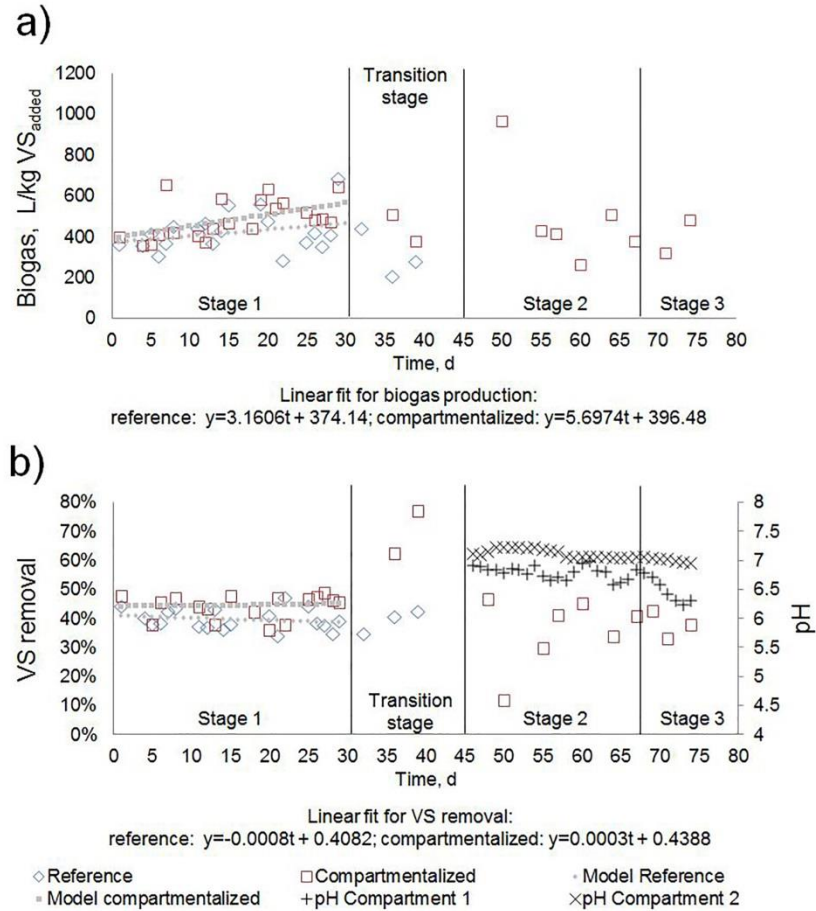

Figure 3.4 (a) Specific biogas production; (b) VS degradation and pH of both reactors.

Table 3.2 Reactor performance.

Parameter	Reference	Compartment 1	Compartment 2
Stage 1 (duration: 30 days)			
OLR, kg VS/m ³ d	1.4 ± 0.3 (n=19)	4.2 ± 0.7 (n=20)	2.7 ± 0.5 (n=21)
Retention time, d	23.2 ± 5.8 (n=26)	7.5 ± 1.1 (n=26)	7.5 ± 1.1 (n=26)
Biogas production, L /kg VS _{added}	425 ± 76 (n=19)	486 ± 90 (n=21)	
CH ₄ content of biogas, %	62 (n=1)	63 (n=1)	
Total biogas produced per compartment, % of total	-	86 ± 3.6 (n=29)	14 ± 3.6 (n=29)
VS degradation, %	39.6 ± 3.5 (n=19)	44.1 ± 4.2 (n=17)	
VFA, mg/L	7.2 ± 1.9 (n=3)	8.8 ± 1.7 (n=3)	4.5 ± 1.6 (n=3)
sCOD/total COD in liquor, %	2.8 ± 0.63 (n=13)	3.7 ± 0.73 (n=13)	4.1 ± 0.89 (n=12)
Stage 2 (duration: 23 days)			
OLR, kg VS/m ³ d		6.5 ± 2.0 (n=7)	4.6 ± 1.1 (n=7)
Retention time, d		4.7 ± 0.7 (n=20)	4.6 ± 0.7 (n=20)
pH		6.8 ± 0.1 (n=23)	7.1 ± 0.1 (n=23)
VFA, mg/L		179 (n=2)	below detection limit (n=2)
sCOD liquor, %		5.3 ± 1.77 (n=9)	4.6 ± 1.58 (n=9)
Stage 3 (duration: 7 days)			

OLR, kg VS/m ³ d		10.0 ± 0.1 (n=2)	6.5 ± 1.0 (n=3)
Retention time, d		3.4 ± 0.4 (n=6)	3.4 ± 0.4 (n=7)
pH		6.5 ± 0.2 (n=7)	7.0 ± 0.0 (n=7)
VFA, mg/L		1915	330

Previous research has shown that improved hydrolysis caused by thermal pre-treatment benefits the stability of the digestion process at reduced retention times (Akgul et al., 2017; Luste and Luostarinen, 2010; Mehdizadeh et al., 2013). Our results support these findings and clearly show that a higher OLR can be attained with a mild thermal pre-treatment in combination with compartmentalized digestion. In addition, the latter reactor showed an increase biogas production and VS degradation. However, a previous study showed opposite results and reported a decline in VS degradation at similar pre-treatment conditions (Luste and Luostarinen, 2010). They applied a pre-treatment at 70 °C for two hours to a mixture of slaughterhouse products (digestive tract content, drum-sieved waste, dissolved air flotation sludge and grease) and secondary sludge in a ratio 1 to 7 by volume. The OLR in the anaerobic digester was raised from 1.8 to 3.7 kg VS/m³d thus reducing the retention time from 25 to 14 d. They observed a drop in absolute VS degradation from 40 % (reference) to 33 % (pre-treated sample). It should be noticed that the addition of a highly reduced substrate, such as slaughterhouse products, could have contributed to the observed unstable digestion performance (Luste and Luostarinen, 2010).

3.3.2.2 Stages #2 and #3

The objective of executing the final experimental stages was to test the resilience of the compartmentalized reactor when imposing short term operational changes. During Stage #2, a 23-day peak load was tested of 6.5 kg VS/m³d with a primary to secondary sludge ratio of 25:75 by weight. The SRT was 4.7 and 4.6 days in compartment 1 and 2, respectively. In Stage #3 the peak load was further augmented to 10 kg VS/m³d during 7 days, by increasing the more rapidly bio-degradable primary sludge to a feed ratio of 40:60 (primary to secondary sludge). The SRT in each compartment was 3.4 days during this stage. Unfortunately, there was no reference reactor available for comparing the response of a conventional digester to these kinds of peak loadings. In Stages #2 and #3, VFA and pH were monitored, which are indicators of process perturbation of anaerobic digestion.

During Stage #2 operation at an OLR of 6.5 kg VS/m³d, the concentration of VFA reached 180 mg VFA/L in the first compartment and was below the detection limit in the second reactor (Table 3.2). Nonetheless, a further increase in OLR to 10 kg VS/m³d in Stage #3 resulted into 1900 and 330 mg VFA/L for the first and second compartment, respectively. The accumulation of VFAs was also reflected in the decline in pH from 7.0 to 6.2 in the first compartment (Figure 3.4b). During the highest loading condition, the ratio of acetate to propionate was 1:0.86, while the concentration of butyrate and valerate was in excess of 50 mg/L each. Such VFAs concentrations have been associated with imbalances in full-scale processes and suggest that in this stage methanogenesis became the rate limiting step. The observed VFAs values in Stage #3 agree with previously reported values using thermal-phased anaerobic digestion, in which a concentration of 4400 mg VFA/L was reached at a retention time of 7 days (Akgul et al., 2017). Similarly, an OLR of 8 kg VS/m³d (retention time of 4.2 d) caused acidification and interruption of biogas production (Gou et al., 2014). In the latter studies, the loss of performance at such loading rates was ascribed to the washout of methanogens. Nonetheless, our results suggest that the

compartmentalized reactor was able to handle peak loadings for at least one retention time (between 7 and 9 days).

3.3.2.3 Effects of mild thermal pre-treatment coupled with hydrogen peroxide

Due to the configuration of the experiment, it was not possible to allocate the observed performance to either thermal pre-treatment or compartmentalized digestion. Nonetheless, based on existing literature, the potential impact of either of both approaches is further discussed. In the present study, mild-temperature pre-treatment coupled with hydrogen peroxide pre-treatment solubilized $13.2\% \pm 5.5$ ($n=23$) of the total COD of the sludge along the complete test duration. The concentration of residual sCOD in the effluent after digestion of both the reference and compartmentalized digester was comparable. It is hypothesized that the increment in sCOD could be a response of the variation in the structural arrangement of extracellular polymeric substances (EPS). EPS form a mechanically stable network of proteins, polysaccharides and lipids that immobilize cells (Flemming and Wingender, 2010) and comprise a major constituent of WAS. The debilitation of this network is expected to diminish the resistance of sludge to biodegradation (Xu et al., 2018). During stage #1, mild-temperature pre-treatment coupled with hydrogen peroxide pre-treatment triggered the transfer of the tightly-bound fraction to soluble fractions of EPS (Figure 3.5a). This effect can be assigned solely to the temperature effect during pre-treatment, as according to Cai and Liu the addition of 0-80 mg H_2O_2 /gTS caused a negligible increase in the solubilization of organic matter (Cai and Liu, 2018).

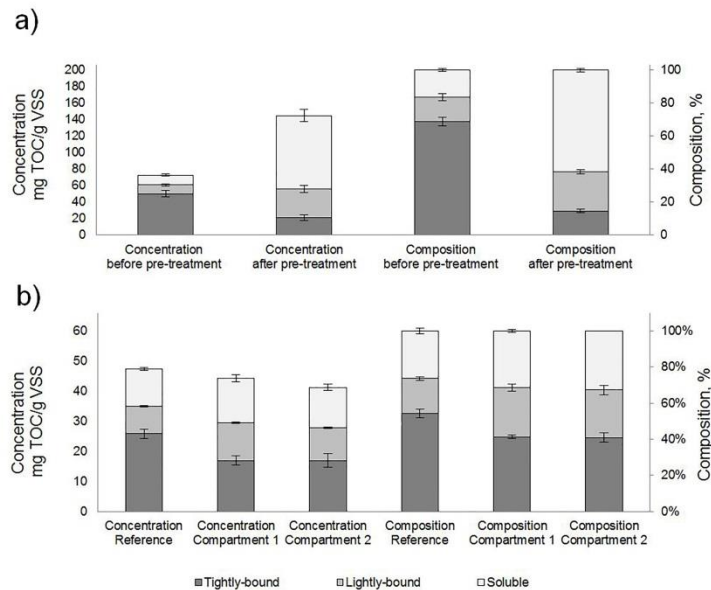

Figure 3.5 EPS concentration and fractionation of EPS (a) before and after pre-treatment, $n=6$; and (b) in the anaerobic liquors, $n=2$.

Likewise, sCOD and EPS were analyzed in the liquors of the first and second compartments, as well as in the reference reactor. During Stage #1, the digestates of both compartments showed similar sCOD concentration, demonstrating that sCOD was mostly converted in the first compartment (Table 3.2). On the other hand, the digestate of the second compartment had a slightly higher amount of sCOD compared to the reference. This observation might be due to a) the formation of recalcitrant

compounds during mild-temperature pre-treatment coupled with H₂O₂ pre-treatment; and/or b) the presence of residual biodegradable sCOD as a result of the shorter retention time of the compartmentalized reactor. The lab-scale experiments showed that after 30 days of digestion around 95 % of the solubilized COD at 70 °C was consumed. Therefore, we infer that the pre-treatment produced mostly biodegradable sCOD rather than recalcitrant compounds.

Figure 3.5b shows the fractionation of EPS of the anaerobic liquors. Since these samples included both primary sludge and the anaerobic biomass, a direct comparison with the profiles of pre-treated WAS is not possible. Nonetheless, it is observed that the concentration and composition of EPS of sludge from the first and second compartment of the compartmentalized digester were similar. In contrast, the reference reactor had a higher amount of tightly-bound EPS and a slightly lower concentration of soluble EPS. This shift evidences that pre-treatment debilitated the EPS network through the breakdown of its most recalcitrant part and transformed it into a more accessible fraction.

3.3.2.4 Effects of compartmentalized-digestion and recirculation

The results of the present research suggest that compartmentalization of digestion indeed provoked a separation of the phases of anaerobic digestion; the first compartment produced the majority of the VFA and biogas, while the second one acted as a polishing and buffering step. This was also reflected in the pH values. During Stage #2 the pH value of the first compartment was lower compared to the second one, i.e., 6.8 ± 0.1 and 7.1 ± 0.1 , respectively. Similarly, recirculation has been reported to improve the hydraulics of reactors and the fluxes of nutrients and metabolites (Zuo et al., 2014). Indeed, recirculation from the second to the first compartment was devised to control pH and alkalinity. Literature has demonstrated that a recirculation of 60% caused an increase in methane yield from 290 to 330 L CH₄/kg VSadded (Zuo et al., 2014). Remarkably, in our study the applied recirculation rate appeared to be irrelevant to affect performance. We hypothesize that the improved performance in the present research was fostered by a) the supply of hydrolyzed sludge via mild-temperature pre-treatment coupled with hydrogen peroxide pre-treatment; and b) to an improved contact between substrate and the anaerobic biomass resulting from compartmentalization.

3.3.2.5 Microbial composition and structure

Samples for microbial community analysis, were taken on days 19 (during Stage #1) and 67 (at the end of Stage #2). In our study, the main limitation for properly interpreting the results was the short-term operation, i.e., about 3 retention times, or about 6 retention times for the individual compartments, a short time for full adaptation of the microbial community. Thus, care should be taken with correlating the observed performance to changes in microbial populations. The dominant four bacteria phyla, i.e. proteobacteria, firmicutes, bacteroidetes, and actinobacteria, accounted for at least 65% of abundance of the community (Figure S3-12), matching previous works (Guo et al., 2015; Kirkegaard et al., 2017). The pre-treatment step reduced the abundance of Proteobacteria and Bacteroidetes, whereas it increased the relative share of Firmicutes and Actinobacteria in the secondary sludge. This implies that Firmicutes and Actinobacteria were likely more resistant to the combined pre-treatment. Similarly, compared to the reference, Firmicutes had a higher abundance in both digester compartments. It has been documented that higher OLRs increase the number of Firmicutes (Carballa et al., 2015), a phylum that has been related with a better performance during phased digestion (P. Wang et al., 2018).

Regarding the archaeal domain, *Methanosaeta* outweighed *Methanosarcina* for both the reference and compartmentalized reactors (Figure S3-13). The striking dominance of *Methanosaeta*, which is characterized by a low growth rate, might have resulted in increased acetate concentrations during the subsequent stages at high OLR.

3.3.2.6 Dewaterability

The dewaterability of the digestate was determined by assessing the CST and by the performance of dewatering tests using a lab-scale filter press and a pilot-scale centrifuge. The dewaterability of the digestate of the compartmentalized digester deteriorated as indicated by the higher CST, polymer doses and water content in the cake, compared to the reference (Table 3.3). The observed decline in dewaterability contrasts with the CST results obtained during the lab-scale experiments, which, however, differed in substrate composition. Nonetheless, we assume that more trustworthy results were obtained during the continuous pilot-scale experiments, because more methods were applied and more samples were analyzed.

Table 3.3 Results of dewaterability assays of pilot-scale experiment.

Method	Digestate	Polymer dose, g/kg TS	Cake solids, %TS	CST, s/gTS
CST	Reference	-	-	14.8 ± 4.3
	Compartmentalized	-	-	24.1 ± 1.7
Lab-scale filter press	Reference	25	19 ± 2.5	-
	Compartmentalized	28	16 ± 3.0	-
Pilot-scale centrifuge	Reference	22	22.5-23.5	-
	Compartmentalized	27	24-25	-

Nonetheless, the decrease in dewaterability may be explained by a decrease in particle size and the solubilization of EPS. As postulated earlier, the mild-temperature pre-treatment coupled with hydrogen peroxide pre-treatment might have dropped the mean particle size of the sludge, resulting in a concomitant increase in surface area for water bounding. The possible decrease in the average particle size might be ascribed to the thermal pre-treatment, since the sole application of hydrogen peroxide had no effect on particle size or specific resistance to filtration in the range 2.5-30 mg H₂O₂/g TSS (Wei et al., 2019). Similarly, the observed variation in the composition of EPS (Figure 3.5) could have caused a change in the water fractions of the sludge. According to (Guo et al., 2016) the presence of soluble and loosely-bound EPS fractions is detrimental for the aggregation of aerobic flocs. In addition, the destruction of the tightly-bound fraction triggers the liberation of proteins to the soluble fraction, which could further deteriorate dewaterability of both aerobic and anaerobic sludge (Murthy and Novak, 1999; Yu et al., 2008; W. Zhang et al., 2015b). The latter consideration agrees with the observed poorer dewatering of the digestate of the compartmentalized reactor.

3.3.3. Energy balance and cost implications

A hypothetical WWTP with a capacity of 250,000 p.e. was considered for the elaboration of an energy balance of the reference and the compartmentalized digester (Table 3.4). The assumptions for the calculation are presented in the supplementary data. Considering the values obtained during Stage #1 of the pilot-scale phase, both the reference and the compartmentalized digester have favorable energy balances, i.e., are net producers of heat and electricity from the WAS-enclosed biochemical energy. Whereas the conventional digester produced more excess heat, the compartmentalized digester had a

potentially higher electricity production. It must be noted that 60% heat recovery after the thermal pre-treatment is required in order to obtain a favorable balance. However, the applied peroxide dose represents a cost of \$2.24 USD per kg TS of sludge, while the 25%-higher polymer dose for dewatering would result into a proportional cost increase. Accepting this, further research should be concentrated on a) optimization of the required H₂O₂ dosage and b) optimization of polymer dosage for sludge dewatering. It should be noted that the availability of an increased digester capacity prevents expenditures on digester construction costs. This benefit may off-set the additional cost of chemicals.

Table 3.4 Heat and energy balance¹.

Parameter	Reference	Compartmentalized
<i>Input values</i>		
Methane production, L CH ₄ / kg VS _{added}	264	306
VS degradation, %	39.6	44.1
TS, g/L	41.2	39.1
VS/TS, unitless	0.76	0.77
Retention time, d	23	15
OLR, kg VS/m ³ d	1.4	4.2
Polymer dose, g/kg TS	22	27
TS dewatered sludge, g/L	230	245
<i>Output values</i>		
Heat required for pre-treatment, kJ/gTS	0	3.81
Reactor heating, kJ/gTS	2.64	0.16
Energy required for transport of cake solids ² , kJ/gTS	0.14	0.13
Electricity requirement for mixing and pumping, kJ/gTS	0.14	0.11
Electrical Energy required polymer and centrifuge, kJ/gTS	0.35	0.39
Heat consumed, kJ/gTS	2.78	4.10
Electrical energy consumed, kJ/gTS	0.49	0.50
Heat produced, kJ/gTS	-3.67	-4.27
Electrical energy produced, kJ/gTS	-2.72	-3.16
<i>Heat and energy balance</i>		
Heat, kJ/gTS	-0.89	-0.17
Electricity, kJ/gTS	-2.23	-2.66

¹ a negative value indicates energy release

² as fuel

3.4 Conclusions

- Pre-treatment resulted in increased methane production rates of waste activated sludge, which was attributed to increased solids hydrolysis, partly linked to a shift from the tightly-bound to the loosely-bound and soluble EPS fractions.
- Pre-treatment and compartmentalized digestion accommodated an increase in applicable OLR from 1.4 to 4.1 kg VS/m³d, resulting in a slight increase in both biogas production and volatile solids degradation. However, digestate dewaterability deteriorated compared to the reference conventional digester. The increase in loading rate can be translated to a reduction in retention time from 23 to 15 days.

- No detrimental process imbalance was observed at a peak OLR of 10 kg VS/m³d during at least one retention time (7 days).

3.5 References

- Akgul, D., Cella, M.A., Eskicioglu, C., 2017. Influences of low-energy input microwave and ultrasonic pretreatments on single-stage and temperature-phased anaerobic digestion (TPAD) of municipal wastewater sludge. *Energy* 123, 271–282. <https://doi.org/10.1016/j.energy.2017.01.152>
- APHA, AWWA, WEF, 2017. *Standard Methods for the Examination of Water and Wastewater*, 23rd ed. American Public Health Association, Washington.
- Appels, L., Degrève, J., Van der Bruggen, B., Van Impe, J., Dewil, R., 2010. Influence of low temperature thermal pre-treatment on sludge solubilisation, heavy metal release and anaerobic digestion. *Bioresour. Technol.* 101, 5743–5748. <https://doi.org/10.1016/j.biortech.2010.02.068>
- Bhattacharya, S.K., Madura, R.L., Walling, D.A., Farrell, J.B., 1996. Volatile solids reduction in two-phase and conventional anaerobic sludge digestion. *Water Res.* 30, 1041–1048. [https://doi.org/https://doi.org/10.1016/0043-1354\(95\)00252-9](https://doi.org/https://doi.org/10.1016/0043-1354(95)00252-9)
- Bokare, A.D., Choi, W., 2014. Review of iron-free Fenton-like systems for activating H₂O₂ in advanced oxidation processes. *J. Hazard. Mater.* 275, 121–135. <https://doi.org/10.1016/j.jhazmat.2014.04.054>
- Cacho Rivero, J.A., Suidan, M.T., 2006. Effect of H₂O₂ dose on the thermo-oxidative co-treatment with anaerobic digestion of excess municipal sludge. *Water Sci. Technol.* 54, 253–259. <https://doi.org/10.2166/wst.2006.513>
- Cai, W., Liu, Y., 2018. Comparative study of dissolved organic matter generated from activated sludge during exposure to hypochlorite, hydrogen peroxide, acid and alkaline: Implications for on-line chemical cleaning of MBR. *Chemosphere* 193, 295–303. <https://doi.org/10.1016/j.chemosphere.2017.11.032>
- Caporaso, J.G., Kuczynski, J., Stombaugh, J., Bittinger, K., Bushman, F.D., Costello, E.K., Fierer, N., Peña, A.G., Goodrich, J.K., Gordon, J.I., Huttley, G.A., Kelley, S.T., Knights, D., Koenig, J.E., Ley, R.E., Lozupone, C.A., Mcdonald, D., Muegge, B.D., Pirrung, M., Reeder, J., Sevinsky, J.R., Turnbaugh, P.J., Walters, W.A., Widmann, J., Yatsunencko, T., Zaneveld, J., Knight, R., 2010. QIIME allows analysis of high-throughput community sequencing data. *Nat. Methods* 7. <https://doi.org/10.1038/nmeth0510-335>
- Carballa, M., Regueiro, L., Lema, J.M., 2015. Microbial management of anaerobic digestion : exploiting the microbiome-functionality nexus. *Curr. Opin. Biotechnol.* 33, 103–111. <https://doi.org/10.1016/j.copbio.2015.01.008>
- Carrère, H., Dumas, C., Battimelli, A., Batstone, D.J., Delgenès, J.P., Steyer, J.P., Ferrer, I., 2010. Pretreatment methods to improve sludge anaerobic degradability: A review. *J. Hazard. Mater.* 183, 1–15. <https://doi.org/10.1016/j.jhazmat.2010.06.129>
- Dai, X., Xu, Y., Dong, B., 2017. Effect of the micron-sized silica particles (MSSP) on biogas conversion of sewage sludge. *Water Res.* 115, 220–228. <https://doi.org/10.1016/j.watres.2017.02.064>
- Edgar, R.C., 2010. Search and clustering orders of magnitude faster than BLAST. *Bioinformatics* 26, 2460–2461. <https://doi.org/10.1093/bioinformatics/btq461>
- Edgar, R.C., Haas, B.J., Clemente, J.C., Quince, C., Knight, R., 2011. UCHIME improves sensitivity and speed of chimera detection. *Bioinformatics* 27, 2194–2200. <https://doi.org/10.1093/bioinformatics/btr381>
- Eskicioglu, C., Prorot, A., Marin, J., Droste, R.L., Kennedy, K.J., 2008. Synergetic pretreatment of sewage sludge by microwave irradiation in presence of H₂O₂ for enhanced anaerobic digestion. *Water Res.* 42, 4674–4682. <https://doi.org/10.1016/j.watres.2008.08.010>
- Flemming, H., Wingender, J., 2010. The biofilm matrix. *Nat. Rev. Microbiol.* 8, 623–33. <https://doi.org/10.1038/nrmicro2415>

- Fu, B., Jiang, Q., Liu, Hongbo, Liu, He, 2014. Occurrence and reactivation of viable but non-culturable *E. coli* in sewage sludge after mesophilic and thermophilic anaerobic digestion. *Biotechnol. Lett.* 36, 273–279. <https://doi.org/10.1007/s10529-013-1361-9>
- Garrido-Ramírez, E.G., Theng, B.K.G., Mora, M.L., 2010. Clays and oxide minerals as catalysts and nanocatalysts in Fenton-like reactions—a review. *Appl. Clay Sci.* 47, 182–192. <https://doi.org/10.1016/j.clay.2009.11.044>
- Ghasimi, D.S.M., de Kreuk, M., Maeng, S.K., Zandvoort, M.H., van Lier, J.B., 2016. High-rate thermophilic bio-methanation of the fine sieved fraction from Dutch municipal raw sewage: Cost-effective potentials for on-site energy recovery. *Appl. Energy* 165, 569–582. <https://doi.org/10.1016/j.apenergy.2015.12.065>
- Gonzalez, A., Hendriks, A.T.W.M., van Lier, J.B., de Kreuk, M., 2018. Pre-treatments to enhance the biodegradability of waste activated sludge: Elucidating the rate limiting step. *Biotechnol. Adv.* 36, 1434–1469. <https://doi.org/10.1016/j.biotechadv.2018.06.001>
- Gou, C., Yang, Z., Huang, J., Wang, H., Xu, H., Wang, L., 2014. Effects of temperature and organic loading rate on the performance and microbial community of anaerobic co-digestion of waste activated sludge and food waste. *Chemosphere* 105, 146–151. <https://doi.org/10.1016/j.chemosphere.2014.01.018>
- Guo, J., Peng, Y., Ni, B., Han, X., Fan, L., Yuan, Z., 2015. Dissecting microbial community structure and methane-producing pathways of a full-scale anaerobic reactor digesting activated sludge from wastewater treatment by metagenomic sequencing. *Microb. Cell Fact.* 14, 1–11. <https://doi.org/10.1186/s12934-015-0218-4>
- Guo, X., Wang, X., Liu, J., 2016. Composition analysis of fractions of extracellular polymeric substances from an activated sludge culture and identification of dominant forces affecting microbial aggregation. *Sci. Rep.* 6. <https://doi.org/10.1038/srep28391>
- Guwy, A.J., Martin, S.R., Hawkes, F.R., Hawkes, D.L., 1999. Catalase activity measurements in suspended aerobic biomass and soil samples. *Enzyme Microb. Technol.* 25, 669–676. [https://doi.org/10.1016/S0141-0229\(99\)00115-5](https://doi.org/10.1016/S0141-0229(99)00115-5)
- Higgins, M.J., Chen, Y., Murthy, S.N., Hendrickson, D., Farrel, J., Schafer, P., 2007. Reactivation and growth of non-culturable indicator bacteria in anaerobically digested biosolids after centrifuge dewatering. *Water Res.* 41, 665–673. <https://doi.org/10.1016/j.watres.2006.09.017>
- Hiraoka, M., Takeda, N., Sakai, S., Yasuda, A., 1985. Highly efficient anaerobic digestion with thermal pretreatment. *Water Sci. Technol.* 17, 529–539. <https://doi.org/10.2166/wst.1985.0157>
- Hosseini Koupaie, E., Johnson, T., Eskicioglu, C., 2017. Advanced anaerobic digestion of municipal sludge using a novel and energy-efficient radio frequency pretreatment system. *Water Res.* 118, 70–81. <https://doi.org/10.1016/j.watres.2017.04.017>
- Jung, H., Kim, J., Lee, S., Lee, C., 2014. Effect of mild-temperature H₂O₂ oxidation on solubilization and anaerobic digestion of waste activated sludge. *Environ. Technol.* 35, 1702–9. <https://doi.org/10.1080/09593330.2014.880517>
- Kirkegaard, R.H., McIlroy, S.J., Kristensen, J.M., Nierychlo, M., Karst, M., Dueholm, M.S., Albertsen, M., Nielsen, P.H., 2017. The impact of immigration on microbial community composition in full-scale anaerobic digesters. *Sci. Rep.* 7.1, 1–11. <https://doi.org/10.1038/s41598-017-09303-0>
- Laurent, J., Pierra, M., Casellas, M., Dagot, C., 2009. Fate of cadmium in activated sludge after changing its physico-chemical properties by thermal treatment. *Chemosphere* 77, 771–777. <https://doi.org/10.1016/j.chemosphere.2009.08.024>
- Liao, X., Li, H., Zhang, Y., Liu, C., Chen, Q., 2016. Accelerated high-solids anaerobic digestion of sewage sludge using low-temperature thermal pretreatment. *Int. Biodeterior. Biodegradation* 106, 141–149. <https://doi.org/10.1016/j.ibiod.2015.10.023>

- Liu, J., Yang, Q., Wang, D., Li, Xiaoming, Zhong, Y., Li, Xin, Deng, Y., Wang, L., Yi, K., Zeng, G., 2016. Enhanced dewaterability of waste activated sludge by Fe(II)-activated peroxydisulfate oxidation. *Bioresour. Technol.* 206, 134–140. <https://doi.org/10.1016/j.biortech.2016.01.088>
- Lo, K. V., Ning, R., de Oliveira, C.K.Y., De Zetter, M., Srinivasan, A., Liao, P.H., 2017. Application of microwave oxidation process for sewage sludge treatment in a continuous-flow system. *J. Environ. Eng.* 143, 1–9. [https://doi.org/10.1061/\(ASCE\)EE.1943-7870.0001247](https://doi.org/10.1061/(ASCE)EE.1943-7870.0001247).
- Luste, S., Luostarinen, S., 2010. Anaerobic co-digestion of meat-processing by-products and sewage sludge—Effect of hygienization and organic loading rate. *Bioresour. Technol.* 101, 2657–2664. <https://doi.org/10.1016/j.biortech.2009.10.071>
- Lv, W., Schanbacher, F.L., Yu, Z., 2010. Putting microbes to work in sequence: Recent advances in temperature-phased anaerobic digestion processes. *Bioresour. Technol.* 101, 9409–9414. <https://doi.org/10.1016/j.biortech.2010.07.100>
- Maspolim, Y., Zhou, Y., Guo, C., Xiao, K., Ng, W.J., 2015. Comparison of single-stage and two-phase anaerobic sludge digestion systems—Performance and microbial community dynamics. *Chemosphere* 140, 54–62. <https://doi.org/10.1016/j.chemosphere.2014.07.028>
- Meek, G.E., Ozgur, C., Dunning, K., 2007. Comparison of the t vs. Wilcoxon Signed-Rank test for likert scale data and small samples. *J. Mod. Appl. Stat. Methods* 6, 91–106. <https://doi.org/10.22237/jmasm/1177992540>
- Mehdizadeh, S.N., Eskicioglu, C., Bobowski, J., Johnson, T., 2013. Conductive heating and microwave hydrolysis under identical heating profiles for advanced anaerobic digestion of municipal sludge. *Water Res.* 47, 5040–5051. <https://doi.org/10.1016/j.watres.2013.05.055>
- Mowla, D., Tran, H.N., Allen, D.G., 2013. A review of the properties of biosludge and its relevance to enhanced dewatering processes. *Biomass and Bioenergy* 58, 365–378. <https://doi.org/10.1016/j.biombioe.2013.09.002>
- Murthy, S.N., Novak, J.T., 1999. Factors Affecting Floc Properties During Aerobic Digestion: Implications for Dewatering. *Water Environ. Res.* 71, 197–202. <https://doi.org/10.2175/106143098X121879>
- Nadler, V., Goldberg, I., Hochman, A., 1986. Comparative study of bacterial catalases. *Biochim. Biophys. Acta (BBA)-General Subj.* 882, 234–241. [https://doi.org/https://doi.org/10.1016/0304-4165\(86\)90160-1](https://doi.org/https://doi.org/10.1016/0304-4165(86)90160-1)
- Neumann, P., Pesante, S., Venegas, M., Vidal, G., 2016. Developments in pre-treatment methods to improve anaerobic digestion of sewage sludge. *Rev. Environ. Sci. Biotechnol.* 15, 173–211. <https://doi.org/10.1007/s11157-016-9396-8>
- Özön, E., Erdinçler, A., 2019. Effects of microwave, H₂O₂/MW and H₂O₂/heat pre-treatments on the methane production from wastewater sludges: experimental and modeling approach. *Environ. Sci. Pollut. Res.* 26, 35411–35421. <https://doi.org/10.1007/s11356-019-05190-2>
- Ruffino, B., Cerutti, A., Campo, G., Scibilia, G., Lorenzi, E., 2019. Improvement of energy recovery from the digestion of waste activated sludge (WAS) through intermediate treatments: The effect of the hydraulic retention time (HRT) of the first-stage digestion. *Appl. Energy* 240, 191–204. <https://doi.org/10.1016/j.apenergy.2019.02.061>
- Sanders, W.T.M., Geerink, M., Zeeman, G., Lettinga, G., 2000. Anaerobic hydrolysis kinetics of particulate substrates. *Water Sci. Technol.* 41, 17–24.
- Vavilin, V.A., Fernandez, B., Palatsi, J., Flotats, X., 2008. Hydrolysis kinetics in anaerobic degradation of particulate organic material: An overview. *Waste Manag.* 28, 939–951. <https://doi.org/10.1016/j.wasman.2007.03.028>
- Wang, P., Wang, H., Qiu, Y., Ren, L., Jiang, B., 2018. Microbial characteristics in anaerobic digestion process of food waste for methane production – A review. *Bioresour. Technol.* 248, 29–36. <https://doi.org/10.1016/j.biortech.2017.06.152>

- Wang, Q., Ye, L., Jiang, G., Jensen, P.D., Batstone, D.J., Yuan, Z., 2013. A novel free nitrous acid (FNA)-based technology for enhancing methane production from waste activated sludge. *Environ. Sci. Technol.* 47, 11897–11904.
- Wei, H., Tang, Y., Shoeib, T., Li, A., Yang, H., 2019. Evaluating the effects of the preoxidation of H₂O₂, NaClO, and KMnO₄ and reflocculation on the dewaterability of sewage sludge. *Chemosphere* 234, 942–952. <https://doi.org/10.1016/j.chemosphere.2019.06.131>
- Xu, Y., Lu, Y., Dai, X., Dong, B., 2017. The influence of organic-binding metals on the biogas conversion of sewage sludge. *Water Res.* 126, 329–341. <https://doi.org/10.1016/j.watres.2017.09.046>
- Xu, Y., Lu, Y., Dai, X., Liu, M., Dai, L., Dong, B., 2018. Spatial configuration of extracellular organic substances responsible for the biogas conversion of sewage sludge. *ACS Sustain. Chem. Eng.* 6, 8308–8316. <https://doi.org/10.1021/acssuschemeng.8b00313>
- Yu, G.H., He, P.J., Shao, L.M., He, P.P., 2008. Stratification structure of sludge flocs with implications to dewaterability. *Environ. Sci. Technol.* 42, 7944–7949. <https://doi.org/https://doi.org/10.1021/es8016717>
- Zhang, W., Yang, P., Yang, X., Chen, Z., Wang, D., 2015. Insights into the respective role of acidification and oxidation for enhancing anaerobic digested sludge dewatering performance with Fenton process. *Bioresour. Technol.* 181, 247–253. <https://doi.org/10.1016/j.biortech.2015.01.003>
- Zhang, X., Hu, J., Spanjers, H., Van Lier, J.B., 2014. Performance of inorganic coagulants in treatment of backwash waters from a brackish aquaculture recirculation system and digestibility of salty sludge. *Aquac. Eng.* 61, 9–16. <https://doi.org/10.1016/j.aquaeng.2014.05.005>
- Zuo, Z., Wu, S., Zhang, W., Dong, R., 2014. Performance of two-stage vegetable waste anaerobic digestion depending on varying recirculation rates. *Bioresour. Technol.* 162, 266–272. <https://doi.org/10.1016/j.biortech.2014.03.156>

Chapter 4. *Vici*: Effects of mild thermal pre-treatment combined with H₂O₂ on waste activated sludge digestibility.

This chapter is originally published as:

Gonzalez, A., van Lier, J.B., de Kreuk, M., (2022). Effects of mild thermal pre-treatment combined with H₂O₂ addition on waste activated sludge digestibility. *Waste Management* 141, 163-172. Doi: 10.1016/j.wasman.2022.01.017

Abstract

The pre-treatment of waste activated sludge (WAS) has become more common since it often results in improved bioconversion to methane, in both rate and extent. However, thorough insights on the possible effects and mechanisms of mild pre-treatment techniques, such as temperatures <100 °C combined with the addition of H₂O₂, are still limited. This study reports the effects of the addition of 5-30 mgH₂O₂/g TS and its interaction with thermal pre-treatment at 70 °C on methane production, using WAS as the substrate. It was found that the addition of H₂O₂ increased the methane production rate, coinciding with a decrease in apparent viscosity of WAS, which probably improved mass transfer under non-ideal mixing conditions. While H₂O₂ solubilized proteins and carbohydrates and mineralized a small fraction of the humic substances in WAS, these biochemical transformations did not suffice to explain the observed extent and rate of methane production. A decreased particle size, the presence of Fenton's reagent, and the presence of cationic polymers in the WAS were discarded as the reasons for the observed decrease in apparent viscosity. It was concluded that the pre-treatment conditions applied in the present study might be a strategy to enhance mixing conditions in full-scale anaerobic digesters.

Keywords: apparent viscosity; catalase activity; cationic polymer; hydroxyl radicals; low-temperature pre-treatment; non-ideal mixing.

4.1 Introduction

Waste activated sludge (WAS) is the main by-product of conventional activated sludge (CAS) wastewater treatment plants (WWTP). Around 14-17 kg as dry solids per person per year are produced in the European Union, Japan and Australia and up to 55 kg TS per person per year in the United States, where kitchen grinders are commonly used (Wu et al., 2020). Due to its putrescible nature, WAS requires a proper disposal, which is commonly achieved via anaerobic digestion (AD) and subsequent landfilling or incineration. The treatment of WAS before AD (WAS pre-treatment) commonly results in improved biogas production, dewatering and hygienization (A. Gonzalez et al., 2018; Neumann et al., 2016). In particular, thermal pre-treatment techniques have been popularized and are commonly categorized into high- and low-temperature using 100 °C as division. In this regard, low-temperature thermal pre-treatment has a lower energy requirement and avoids the use of pressured vessels, steam and sophisticated control systems (Pilli et al., 2014). Various studies have combined low-temperature thermal pre-treatment with chemical reagents, such as hydrogen peroxide (H₂O₂) to potentiate the benefits of pre-treatment. For instance, pre-treatment using microwaves combined with H₂O₂ has resulted in synergetic increases in methane production rate and extent, sludge stabilization and a decrease in apparent viscosity of sludge and digestate (Ambrose et al., 2020; Liu et al., 2016; Wang et al., 2009). The observed effects of microwave-H₂O₂ pre-treatment have been attributed to oxidizing by-products or side-reactions, such as Fenton's reagent and superoxide radicals (Ambrose et al., 2020; Xiao et al., 2012; Yu et al., 2016). Nonetheless, such claims have not been thoroughly researched, probably because of the difficulty of measuring oxidizing species such as hydroxyl radicals. In addition, it is unclear how each pre-treatment individually contributes to the reported improvements in solubilization, methane production and to the decreased WAS viscosity.

In our present research, convectional thermal pre-treatment at 70 °C was used instead of microwaves, since the application of temperature via microwave irradiation or heating via convection has yielded similar results (Eskicioglu et al., 2007; A. Gonzalez et al., 2018). In view of any possible full-scale application, convectional heat is considered more cost-effective, as it avoids the capital cost and electricity consumption of microwave equipment. The objective of our present work is to clarify the effects of convectional thermal pretreatment at 70 °C combined with H₂O₂ addition on WAS, as well as to provide insights about the previously-reported increases in methane production.

4.2 Methods

4.2.1 Sludge origin and characteristics

WAS was obtained from the wastewater treatment plant Kralingseveer (KV) (Rotterdam, The Netherlands) in September (autumn). The sludge was collected after the centrifugation step and therefore included the conditioning agent (cationic polymer) VTA LC 186 (VTA Austria GmbH, Austria). Physicochemical characteristics of WAS were as follows: TS=79.7 g/L; VS=56.8 g/L; COD=86.1 g/L. The same WAS batch was pre-treated (see Section 2.2) in multiple events to ensure sufficient sludge was available to perform all the analytical assays. In addition, samples from two other wastewater treatment plants were taken to perform rheometric assays: Nieuwgraaf (NG) (Arnhem, The Netherlands), with TS=61.2 g/L and VS=48.1 g/L and Harnaschpolder (HP) (Den Hoorn, The Netherlands), with TS=53.2 g/L and VS=41.9 g/L. Digestate was obtained from Harnaschpolder treatment plant, with TS=35.3 g/L and VS=25.4 g/L. The anaerobic digesters in Harnaschpolder were operated with a retention time of ~21 days at 37 °C.

4.2.2 WAS pre-treatment

Thermal pre-treatment of WAS was performed as shown in Gonzalez et al., (2021). H₂O₂ at a concentration of 30 % w/w (Merck, U.S.A.) was dosed according to the designated concentrations. In the pre-treatments without H₂O₂, demineralized water was added to balance the liquid volume. In addition, the added water also compensates the production of water after H₂O₂ addition (Equation 1). The amount of added water always was <2 mL or <0.5 % of the total WAS mass.



Since the dosage strategy or sequence of H₂O₂ application has been observed to markedly influence the outcomes of pre-treatment (Ambrose et al., 2020; Gan and Li, 2013; Pignatello et al., 2006), the addition of either H₂O₂ or water proceeded 10 min after WAS reached a temperature of 70 °C; then the temperature was maintained for 30 min. The chosen strategy agrees with Wang et al. (2009) and is based on the rationale that pre-incubation at 70 °C would lead to denaturation of catalase before H₂O₂ is added. In addition, the time lapse of 20 min at 70 °C after H₂O₂ addition would promote fast decomposition of H₂O₂ (Wu and Qian, 2018), preventing peroxide from entering the anaerobic digesters. Oxidation-reduction potential (ORP) was chosen as surrogate for H₂O₂ detection, since photometric detection of H₂O₂ from the WAS matrix probed to yield into stoichiometrically impossible concentrations, probably due to interferences. Temperature, pH and ORP were carefully measured during each pre-treatment to ensure similar pre-treatment conditions for each pre-treatment event, as detailed next.

4.2.3 Analytical

4.2.3.1. COD, pH, solids, VFA, ORP and pH.

Total solids (TS); volatile solids (VS); chemical oxygen demand (COD); and volatile fatty acids (VFA) were measured as described previously (Gonzalez et al., 2020). pH was measured with a SenTix 940 IDS probe (WTW, Germany) and oxidation-reduction potential (ORP) with a SenTix ORP-T 900 (WTW, Germany). The pH probe was calibrated daily and the ORP probe was checked for accuracy with a standard solution before each use. Data was captured with a multimeter model 3620 IDS (WTW, Germany). Finally, temperature was measured with two digital thermometers model G1710 (Greisinger, Germany).

4.2.3.2. Rheometry.

Shear stress and shear rate were measured using a rotational rheometer model MCR 302 (Anton Paar GmbH, Graz, Austria) with a smooth measuring cylinder model B-CC27 with a diameter of 26.66 mm and a measuring cup model C-CC27 with a diameter of 30 mm. The volume of the sample was ~17 mL and the assays were performed at 35 ± 0.2 °C and lasted ~3 min. A shear rate from 0.01 to 1000 s⁻¹ with a logarithm curve was applied, without a pre-shearing stage. The obtained rheograms were fitted to the Herschel-Bulkley model, which has been observed to be a suitable model for non-Newtonian fluids such as concentrated WAS (Liu et al., 2016; Wei et al., 2018). (Equation 2):

$$\tau = \tau_y + k\dot{\gamma}^n \quad \text{Equation 2}$$

Where:

τ=shear stress, Pa

τ_y=yield stress, Pa

k =consistency index, Pa·s
 $\dot{\gamma}$ =shear rate, s⁻¹
 n =flow behavior index, unitless

Storage and loss moduli (G' and G'' , respectively) describe the elastic and viscous properties of viscoelastic materials. G' relates to the solid-like behavior and G'' to the liquid-like behavior of a sample (AntonPaar, 2021) (Equations 3 and 4). The strain at which $G''=G'$, is the deformation required for the sample to start behaving from a solid-like to a liquid-like behavior.

$$G' = \frac{\sigma_0}{\varepsilon_0} \cos\delta \quad \text{Equation 3}$$

$$G'' = \frac{\sigma_0}{\varepsilon_0} \sin\delta \quad \text{Equation 4}$$

Where:

G' = storage modulus, Pa

G'' = loss modulus, Pa

σ_0 = initial stress, Pa

ε_0 = initial strain, m/m

δ = phase-shift angle

Both G' and G'' were measured using a stainless-steel plate model I-PP80/SS with a diameter of 80 mm and a cone plate model CP50 with a diameter of 50 mm, an angle of 1.001 ° and a truncation of 102 μm. Both implements were manufactured by Anton Paar (Anton Paar GmbH, Graz, Austria). Around 3 mL of WAS were used and the temperature was controlled at 35 ± 0.2 °C. The strain was logarithmically applied from 0.01 % to 100 %. The duration of each assay was ~5 min.

4.2.3.3. Particle size distribution (PSD).

A laser diffraction instrument model Microtrac MRB's Bluewave (Microtrac Retsch GmbH, Germany) was used to measure PSD. The WAS samples were diluted 1:5 with a solution of 0.05 % NaCl (w/v) and analyzed.

4.2.3.4. Catalase activity test.

Catalase activity assay was based on the method of Iwase et al. (2013). Briefly, a sample of unknown concentration of catalase, surfactant and H₂O₂ are combined in a test tube. The oxygen generated by the enzymatic decomposition of H₂O₂ is trapped by the surfactant, producing foam. The height of the foam column is proportional to the concentration of catalase and is related to a calibration curve. Catalase from bovine liver (CAS 9001-05-2 with 2000-5000 units/mg protein, and 65 % protein) from Sigma (Sigma-Aldrich, U.S.A.) was used as standard. Solutions of catalase with concentrations of 0, 25, 50 and 100 enzymatic units (U) were prepared for the calibration curve. Triton X-100 from Sigma was used as surfactant and H₂O₂ at a concentration of 30 % w/w was obtained from Merck (U.S.A.). WAS was diluted 1:5 and 0.1 mL were added to a test tube model 114724 from Merck. Then, 0.1 mL of 1 % Triton X-100 was added together with 0.1 mL of H₂O₂. All the dilutions were performed with demineralized water. The test tube was gently stirred by hand and allowed to rest for 5 min at 20 °C. Finally, the height of foam was measured with a ruler and compared with the standard curve. The analysis was performed in triplicates.

4.2.3.5. Measurement of hydroxyl radicals.

Quantification of HO radicals (HO·) proceeded as follows:

Disodium terephthalate (Na₂TA) (Alfa Aesar, U.S.A) was used as a molecular probe (Charbouillot et al., 2011; D. Gonzalez et al., 2018) at a Na₂TA:Fe molar ratio of 2. Depending on the experiment, either H₂O₂ or water was added to the WAS and the sludge was held for 30 min at 70 °C. A sample of 25 g of pre-treated sludge was diluted 1:2 with demineralized water and centrifuged at 15,000 g (gravitational acceleration units) for 10 minutes using a centrifuge model Sorvall ST 16 (Thermo Fisher Scientific, U.S.A.). The supernatant was filtered through a polytetrafluoroethylene (PTFE) filter (Macherey-Nagel GmbH & Co, Düren, Germany) with a nominal pore-size of 0.45 µm. The filtered sample was then pipetted into a well of a 96-well Bio-One Cell star microplate (Greiner Bio-One GmbH, Austria) and analyzed with a spectrophotofluorometer model Polar Star Optima, (BMG Lab Tech, U.S.A.). The reaction between Na₂TA and HO· results in 2-hydroxyterephthalate (2hTA), which is detected at (λ_{exc} = 320 nm and λ_{em} =420 nm) (Fang et al., 1996). A calibration curve was prepared with 2hTA obtained from Sigma at concentrations of 0.0, 2.5, 5.0 and 7.5 µM. The yield of the reaction between HO· and 2hTA was assumed to be 35 % for samples containing H₂O₂ (Fang et al., 1996) and 87 % for samples without H₂O₂ (Charbouillot et al., 2011). To validate the viability of the probe, WAS was exposed to 70 °C with 15 mg H₂O₂/g TS and sonicated with a digital sonicator model 250 (Branson Ultrasonics Corp., U.S.A 250) with a frequency of 20 kHz and at a specific energy of 3.06 kW/g TS. Sonication is an established method for the production of HO· (Le et al., 2015; Pilli et al., 2011). The duration of the sonication was 30 min and the temperature increase was < 1 °C. The sonicated sample was compared to a non-sonicated control. Compared to control, the sonicated sample had a higher concentration of Na₂TA (Figure S4-1), demonstrating the sensitivity and suitability of Na₂TA for the quantification of HO·.

4.2.3.6. Methane production rate (k_{CH_4}) and specific methane production (SMP).

k_{CH_4} and SMP were determined as described previously (Gonzalez et al., 2020). SMP values are reported as volume of methane per gram of added VS of the un-treated WAS; that is, without considering any possible mineralization of sludge as a result of pre-treatment. Regarding the first order kinetic model, a two-substrate model was used, using as division the best apparent curve fitting. Anaerobic digestate was mixed with a substrate to inoculum ratio of 1:2 (as VS). Two SMP tests were performed: the objective of the first set was to compare the SMP of a) non-treated WAS; b) WAS pre-treated at 70 °C; and c) WAS at 70 °C with 15 mg H₂O₂/g TS. Digestate (see section 2.1) was degassed for 7 days at 35 °C. Bottles with a working volume of 400 mL were agitated with an orbital incubator shaker model Innova 40 (Eppendorf, Germany) at a rotational speed of 120 rpm at 35 °C. The produced biogas was scrubbed with 80 mL of 3 M NaOH solution and the exit gas was measured in a gas volume measuring device (BPC, Sweden). Crystalline cellulose (Sigma-Aldrich, U.S.A.) was used as a control substrate and tap water was added to the bottles containing the control and blank samples until all the bottles had a similar head space. The objective of the second SMP test was to compare the effects of different mixing regimes and WAS rheology on the production of methane. The test consisted of 30 bottles (each with a working volume of 400 mL): half of them were mixed with an orbital incubator shaker model Innova 44 (Eppendorf, Germany) with a rotational speed of 120 rpm. The other bottles were stirred with the Multifunction Brushless DC motor included in the AMPTS-II (BPC, Sweden). For each mixing mode, a cellulose control was prepared as described above. The rotational speed of the AMPTS-II motors was set to ~160 rpm for each motor and was monitored with a tachometer model DT-30LK (Votcraft, Germany). The stirring cycle was: 5 min on; 30 s off, with alternative bidirectional mixing. For each mixing regime,

the temperature was monitored at 35.0 ± 0.2 °C. For the second test, digestate was stored for 4 days at 4 °C.

4.2.3.7. Extracellular polymeric substances (EPS) extraction; EPS composition; and Inductively Coupled Plasma Optical Emission Spectrometry (ICP-OES)

Measurements were performed as described in Gonzalez et al., (2021) in order to determine the Fe concentration in WAS.

4.2.3.8. Viscosity of solutions of model molecules.

Solutions of food-grade hydrolyzed collagen (Plent, Schagen, The Netherlands); analytical-grade humic acid sodium salt (Sigma-Aldrich, U.S. A); and analytical-grade crystalline cellulose (Carl Roth GmbH & Co KG, Germany) were prepared as model molecules of protein, humic substance and carbohydrates, respectively. Demineralized water was used to prepare the solutions, which were as concentrated as possible but still able of being mechanically mixed with magnetic stirrers. The resulting TS concentrations and VS fractions were: 411 mg collagen/g at 96% VS; 305 mg humic acid/g at 27% VS; and 269 mg cellulose/g at 100 % VS. 80 mL of each solution, were exposed to the same conditions as the pre-treatment settings shown in section 2.2 and the resulting broths were subjected to rheometric assays as shown in section 2.3.2.

4.3 Results and discussion

4.3.1 Physicochemical parameters

During pre-treatment, the breakdown of H_2O_2 by catalase (the enzyme that mediates the decomposition of H_2O_2 into water and oxygen) (Wang et al., 2009) will result in misused reagent; thus, catalase must be inactivated via thermal denaturation to ensure H_2O_2 is available for other reactions. Previous research showed that catalase is denatured at temperatures ranging from 60 to 80 °C, depending on the time of exposure (Eyster, 1950; Liu et al., 2015; Velayati et al., 2019). In the present study, the effects of temperature on the activity of catalase were clearly observed (Figure S4-2a and b); catalase activity was no longer present after only 2 min of exposure to a temperature of 70 °C (Figure S4-2b).

The decomposition of H_2O_2 and its possible oxidizing derivatives were monitored via oxidation-reduction potential (ORP) measurements. Dewatered WAS showed a negative ORP (reducing conditions) due to the high oxygen-consuming activity of the activated sludge. Figure 4.1a shows that the exposure of WAS to 70 °C only caused a marginal increase in ORP that likely can be ascribed to intensive mixing during pre-treatment, which induced aeration of the sample. As expected, the application of H_2O_2 sharply increased the ORP until oxidizing conditions (Figure 4.1b) but the ORP decreased smoothly to a reducing environment after 9-12 minutes of dosing, suggesting the progressive decomposition of H_2O_2 and its possible oxidizing by-products, thus preventing their entrance to anaerobic digesters. Figure 4.1c shows an increase in temperature of almost 2 °C, indicating the exothermic nature of the reaction between H_2O_2 and the WAS components. The pH decreased almost 1 unit during pre-treatment with or without H_2O_2 (Figure 4.1d), which coincided with the formation of VFAs during thermal pre-treatment. Nonetheless, the observed decline in pH (< 1 unit) seems insufficient to attribute any potential effect of H_2O_2 to a pH-related mechanism, although a small but sharp drop coincided with H_2O_2 addition.

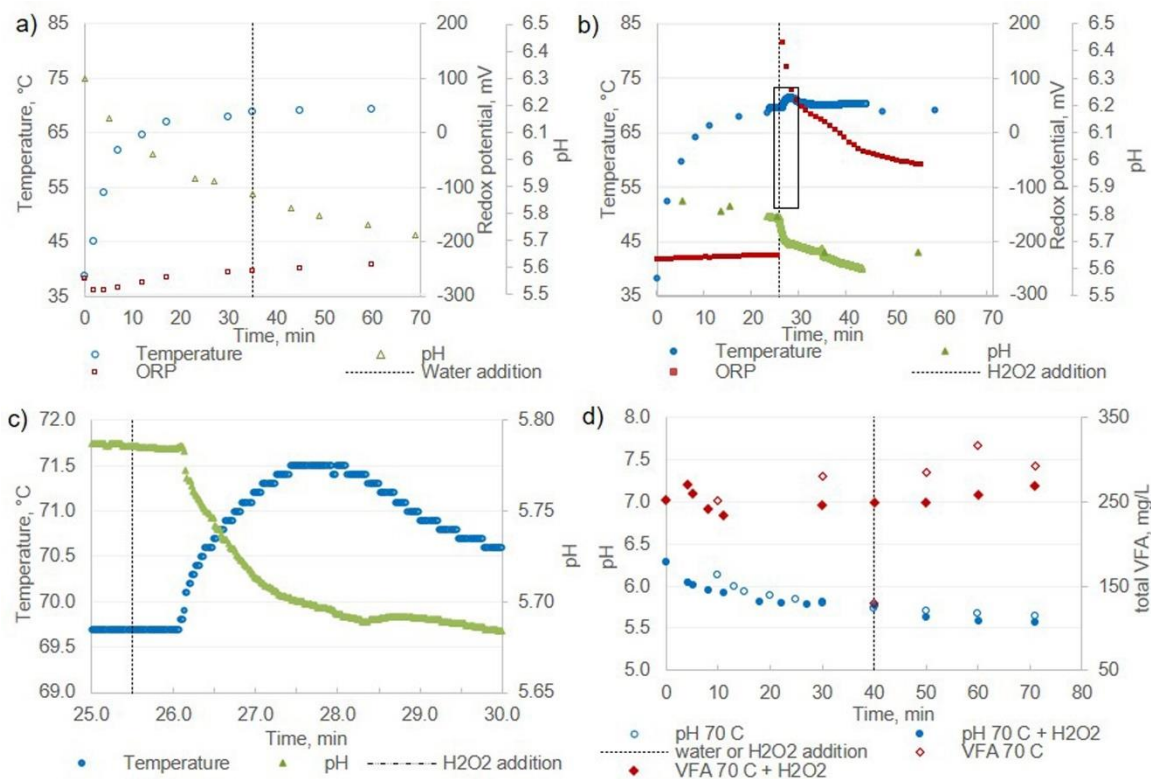

Figure 4.1 Temperature, pH and ORP of WAS during pre-treatment at a) 70 °C; b) 70 °C with 15 mg H₂O₂/g TS, (squared area is shown in Figure 4.1c); c) zoom of squared areas in Figure 4.1b; and d) pH and VFA of sludge pre-treated at 70 °C with and without H₂O₂.

After pre-treatment, the concentration of solids and COD of the sludge samples was analyzed. Figure S4-3 shows that H₂O₂ provoked a slight decrease in TS, VS and COD, suggesting mineralization of organic matter (Eskicioglu et al., 2008; Xiao et al., 2012). Based on the COD mass balance and the redox half-reactions of H₂O₂, it was calculated that the number of electrons donated by the sludge was more than 8 times higher than the potentially scavenged electrons by the dosed H₂O₂ (Annex A in Supplementary Information), suggesting that some mineralization indeed occurred during pre-treatment. The occurrence of mineralization reactions may be explained by an increased effectiveness of H₂O₂, due to the absence of catalase and the increased H₂O₂ reaction rate at the applied temperature.

4.3.2 EPS

The exposure of WAS to 70 °C resulted in a marked increase in concentration of extractable proteins, humic substances and carbohydrates and a shift of these compounds from the tightly bound fraction to the loosely and soluble fraction (Figure 4-2a to c). These trends coincide with previous reports under similar pre-treatment conditions (Liang et al., 2020; Zhen et al., 2019). However, while the addition of 15 mg H₂O₂/ g TS triggered a further increase in the concentration of extractable proteins and carbohydrates (Figure 4.2a and c), there was a slight decrease in the concentration of humic substances when the sludge was exposed to H₂O₂ (Figure 4.2b). Humic acids are less soluble under acidic conditions. However, both pre-treatment conditions resulted in similar pH drops, although the H₂O₂-treated samples had a more abrupt decline immediately after the addition of peroxide (Figure 4.1a and b). The decrease in extractable humic substances was also observed when the experiment was repeated using a different sludge sample (Figure S4-4). Based on the observed results, it was postulated that H₂O₂

degraded a fraction of the humic substances in WAS, which resulted in the observed decrease in VS and COD (Figure S4-3). In previous studies, the degradation of humic matter was observed after the application of H₂O₂ during microwave pre-treatment of WAS (Eskicioglu et al., 2008) and lignite (Doskočil et al., 2014).

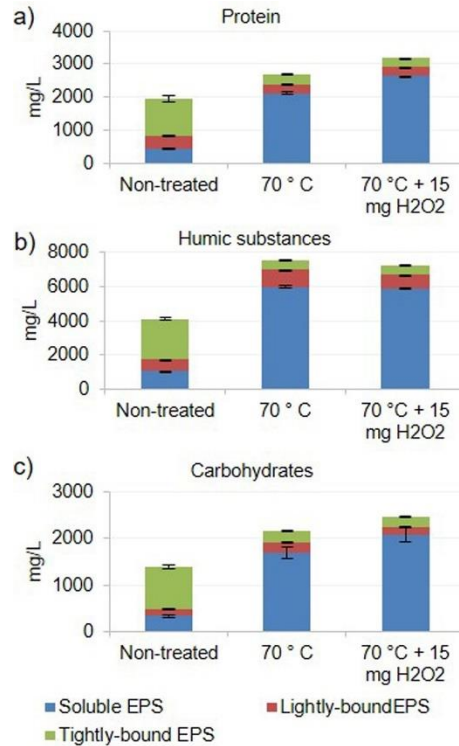

Figure 4.2 Concentration and fractionation of extractable EPS into a) proteins; b) humic substances; and c) carbohydrates, applying the different treatment methods. A modification in the total measured fractions implies a change in extractable EPS upon treatment.

4.3.3 Rheology

As reported for similar temperatures (Hammadi et al., 2012; Wei et al., 2021), the exposure of WAS to 70 °C resulted in an overall decrease in shear stress at shear rates 0.01-1000 s⁻¹ (Figure 4.3a and Figure S4-5). However, the addition of 5-30 mgH₂O₂/g TS provoked a further decrease in shear stress, and thus, in the apparent viscosity of WAS, particularly in the shear rate range that is considered typical for the flow velocity gradients in full scale digesters (0.14 – 1.0 s⁻¹)(Figure 4.3b) (Dapelo and Bridgeman, 2018; Wei, 2021). A decrease in apparent viscosity was also reported by Liu et al. (2016), using microwave heating at 100 °C, with a 10-fold higher H₂O₂-dose than in the present study.

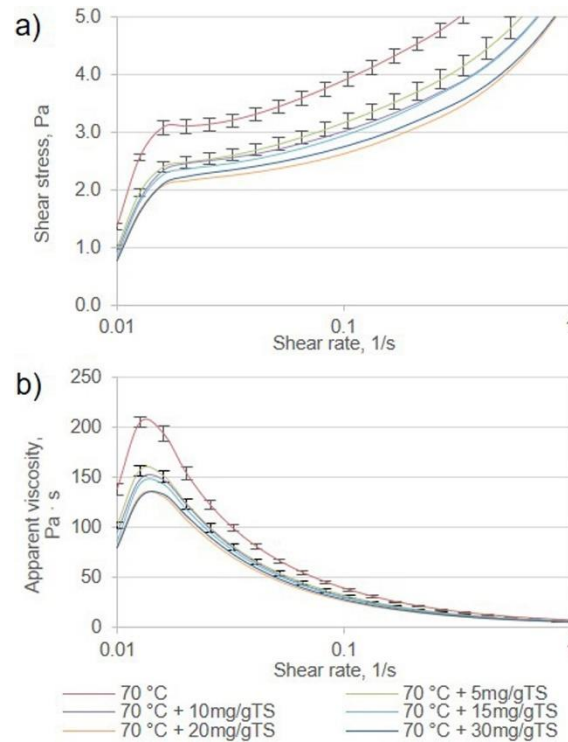

Figure 4.3 a) Rheograms and; b) apparent viscosity for different pre-treatment conditions in the shear rate range 0.01 – 1 s⁻¹. WAS from Nieuwgraaf with TS=61.2 gTS/L; n=3.

Previous studies have shown that the rheological properties of the fermentation liquor impact the mass transfer and short-circuiting during mixing in both lab- and full-scale digesters (Liu et al., 2018; Samstag et al., 2016; Wei et al., 2019). In addition, sludge viscosity impacts the economics of sludge management since it influences mass-transfer rates (Liu et al., 2018; Ratkovich et al., 2012): the lower the apparent viscosity of the fermentation liquor, the better the mixing performance, the higher the biogas production rate, and the lower the occurrence of dead-zones under non-ideal mixing conditions (Liu et al., 2018; Miryahyaei et al., 2019; Wei et al., 2019).

Moreover, the consistency index k (which is a proxy of viscosity)(Equation 2) and the loss modulus G'' (Equation 4) have been demonstrated as indicators for the level of biogas production in lab-scale experiments (Miryahyaei et al., 2019). Thus, it was hypothesized that the decrease in k , G'' , and WAS yield stress (τ_y), might result in increased biogas production as studied in section 3.4. The parameters of the Herschel-Buckley model (Equation 2) were calculated via curve fitting of the rheograms in Figure 4.3. The fitted curves and tabulated values are shown in Figure S4-6 and Table S4-1.

Figure 4.4a shows a clear decrease in consistency index with a dose of 5 mg H₂O₂/g TS, and a further modest decrease was observed proportional to the concentration of H₂O₂. Apparently, WAS viscosity lowered in proportion to the dose of H₂O₂. Similarly, also the yield stress for WAS dosed with 5 mg H₂O₂/g TS decreased; however, there was no additional decrease for higher H₂O₂ doses. The flow behavior index (n) had a constant increase in proportion to the H₂O₂ concentration (Figure 4.4b), suggesting that the pre-treated WAS became a more Newtonian fluid with every increase in H₂O₂ concentration. Overall, our results indicate that the WAS pre-treated with H₂O₂ increased its fluidity,

which is in line with the findings of Liu et al. (2016), which were obtained with a 10-fold higher H₂O₂ dose.

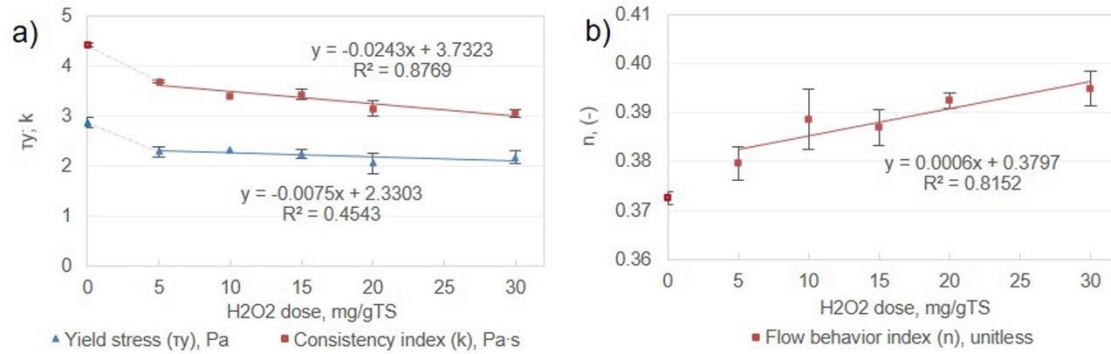

Figure 4.4 Correlation between dose of H₂O₂ and a) yield stress and consistency index; and b) flow behavior index in WAS pre-treated at 70 °C; n=3.

The effect of H₂O₂ on WAS shear stress and apparent viscosity was verified using WAS samples from two other WWTPs, i.e., Kralingseveer WWTP (KV) and Harnaschpolder WWTP (HP). From KV, 2 samples were collected with a time difference of around one month (equivalent to a 1.5 SRT in the aeration tank). The chosen pre-treatment settings were similar to our pilot study (Gonzalez et al., 2020), i.e., a temperature of 70 °C with 15 mg H₂O₂/g TS. Overall, the above-presented results seemed reproducible for both the KV and HP WAS samples (Figure S4-7 and Figure S4-8).

Storage (G') and loss (G'') moduli were measured to assess the effect of pre-treatment on viscoelastic properties. Figure S4-9a shows that non-treated WAS required a strain of ~35 % for G'' to equate G' . On the other hand, Figures S4-9b and c, show that the pre-treated samples required a strain of ~17-20 % to equate both moduli. This implies that a lower deformation was required to provoke a liquid-like behavior of pre-treated WAS, although very similar values were registered between WAS pre-treated at 70 °C with and without the addition of H₂O₂. This observation disagrees with the results of the other measured rheological parameters, although limitations in the analytical method (e.g., size of cone plate, heterogeneity and volume of the sample) could have played a role in this result.

The stepped dosing of H₂O₂ compared to a single-dose application was assessed as an approach to reduce the demand of hydrogen peroxide (Gan and Li, 2013; Pignatello et al., 2006). It was hypothesized that the partitioning of the dose into 3 events separated by 10 minutes could result in a higher reaction yield and would promote a more notable decrease in shear stress. However, it was observed that the stepped dosing mode had no additional effect on the decrease in shear stress (Figure S4-10). Moreover, when compared to a single-dose application, the ORP of the stepped-dosed WAS did not return to reducing conditions. This implies that H₂O₂ and/or its derivatives were not completely converted during pre-treatment and the possible entrance of oxidative species into the anaerobic reactor might have occurred (Figure S4-11).

4.3.4 Methane production rate and extent

We assessed the ability of the used pre-treatment to increase methane production of WAS, considering two possible mechanisms: a biochemical one, caused by higher accessibility of the biodegradable matter, i.e., EPS as indicated in Figure 4.3 and VFA; and a physical one, induced by the modification of WAS rheology (Liu et al., 2016). The concentration of volatile fatty acids (VFAs) during AD of WAS at 35

°C is shown in Figure S4-12. AD of WAS samples started with a similar VFA concentration for all conditions (Figure S4-12a to c), implying that any VFAs produced during pre-treatment were diluted by the inoculum to a negligible concentration. For the pre-treated samples, the VFA concentrations increased sharply after 3 hours of digestion and remained higher than the reference until hour 168 (day 7) (Figure S4-12a' to c'). However, there was no clear difference in composition and only small differences in concentration of VFAs caused by the addition of H₂O₂. Overall, results suggest that VFA production was slightly stimulated by the pre-treatment. After hour 168, the VFA concentration of all samples was comparable.

Regarding methane production, Figure 4.5 demonstrates that the addition of H₂O₂ to WAS exposed to 70 °C did not increase its SMP compared to the sole application of temperature. However, both pre-treatment settings increased the SMP relative to the non-treated WAS, in agreement with the VFA concentrations shown in Figure S4-12.

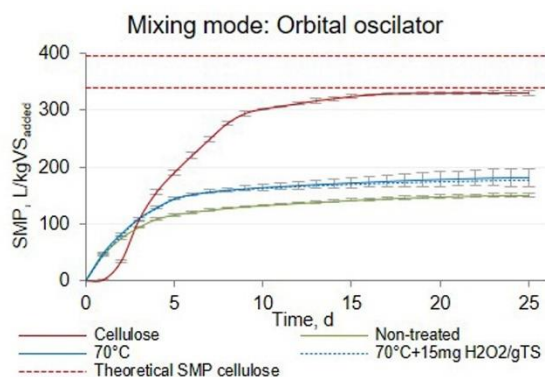

Figure 4.5 SMP of cellulose and WAS at different pre-treatment conditions.

Another incubation was performed to assess the effects of mixing on methane production. The incubation was performed under two different mixing regimes: orbital shaker and stirring (using AMPTS-II motors (BPC, Sweden)). It should be noted that WAS pre-treated at 70°C without H₂O₂ was not assayed as there was no clear difference in SMP compared to the sample including H₂O₂, as shown in Figure 4.5. Additionally, the rheograms of the fermentation liquors were assessed and results are shown in Figure S4-13. Figure 4.6 shows the resulting SMP curves and Table 4.1 lists the calculated kinetic parameters.

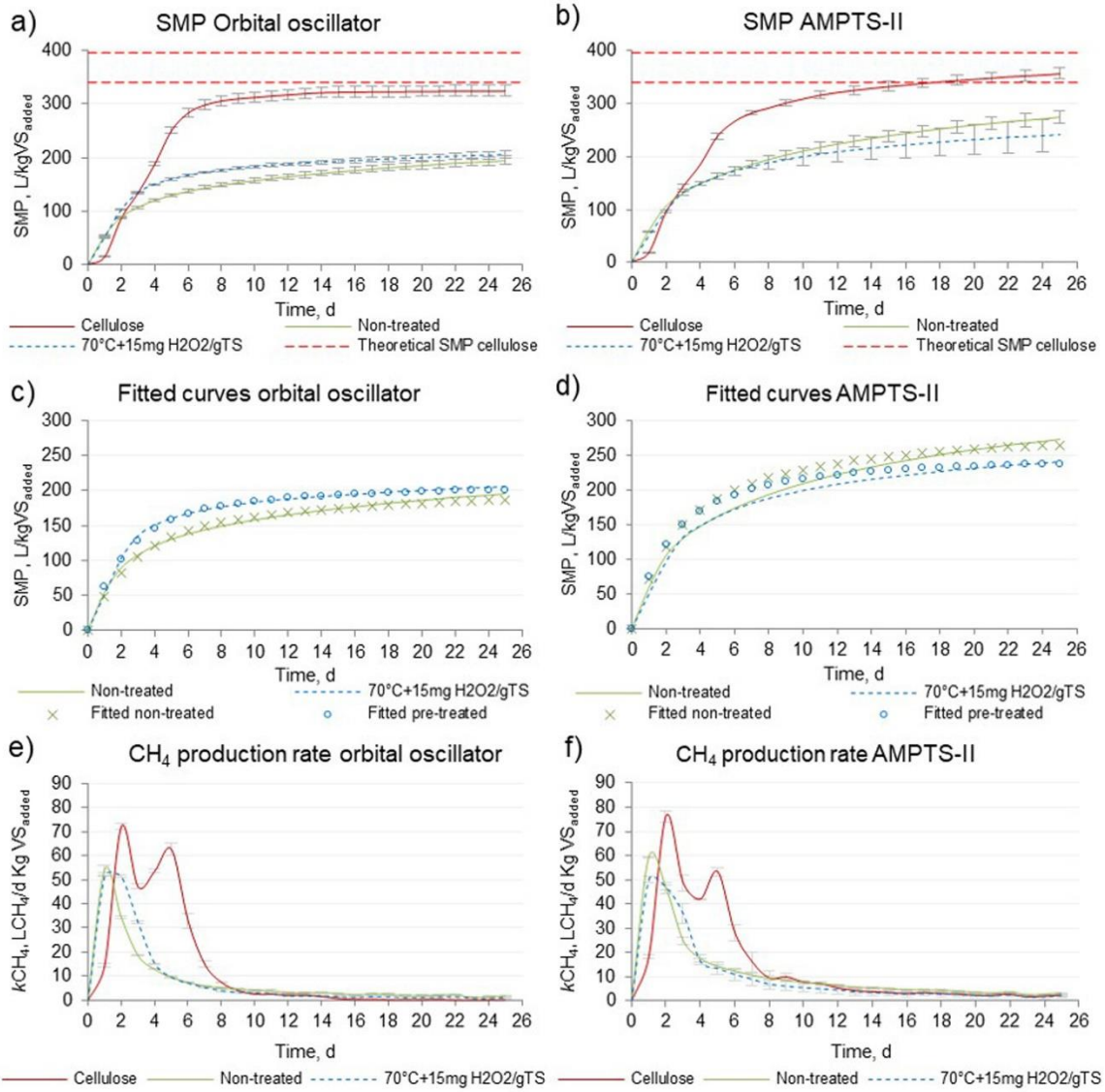

Figure 4.6 SMP (a and b); fitted SMP-curves (c and d); and methane production rate (e and f), using cellulose, non-treated and pre-treated WAS as the substrate under different mixing conditions: orbital shaker (a, c and e) and AMPTS-II (b, d and f); n=3.

Table 4.1 SMP kinetic parameters at different mixing conditions, n=3.

Mixing condition	Orbital shaker			AMPTS-II		
	Substrate	Substrate	70 °C + 15 mg H ₂ O ₂ /g TS	Substrate	Substrate	70 °C + 15 mg H ₂ O ₂ /g TS
$k_{CH4-rapid}^1, d^{-1}$	-	0.44 ± 0.01	0.47 ± 0.01	-	0.51 ± 0.03	0.55 ± 0.08

$k_{CH4-slow}^1, d^{-1}$	-	0.09 ± 0.00	0.11 ± 0.01	-	0.11 ± 0.00	0.13 ± 0.02
Sum of squares, $\Sigma(model-measured)^2$		510.8	235.6		5603.7	4872.2
SMP, NLCH ₄ /kg VS _{added}	324 ± 10	195 ± 7.7	206 ± 7.2	357 ± 10.2	274 ± 12.6	242 ± 31.2
Biodegradation, % ²	82.1 ± 2.6	36.7 ± 1.4	38.7 ± 1.3	90.3 ± 2.6	51.6 ± 2.4	45.5 ± 5.9

¹ The division between $k_{CH4-rapid}$ and $k_{CH4-slow}$ was set at the 4th day of digestion for the orbital shaker and at the 2nd day for AMPTS-II. ² Assuming that 1 g COD produces 0.35 L of methane.

As shown in Figure 4.6 and Table 4.1, the samples incubated in the orbital shaker showed lower values for the kinetic parameters, suggesting non-ideal mixing conditions compared to the stirrers of the AMPTS-II (Table 4.1). For instance, the SMP curves of cellulose incubated in the orbital oscillator reached a plateau after ~10 days without reaching the minimum expected theoretical SMP of 340-395 NLCH₄/kgVS_{added} proposed by Hafner et al., (2020). In contrast, the methane yield of the AMPTS cellulose incubations was in the expected range (Figure 4.6a and b). Regarding the sludge samples, which were incubated under the orbital oscillator mixing conditions, we observed that the lower viscosity brought about by pre-treatment, resulted in increased methane production rates of the pre-treated samples compared to the non-treated ones. As a consequence, more methane was produced for the treated sample until day ~18th (Figure 4.6a), although ultimately the SMP values were similar. Apparently, the pre-treatment at 70 °C with 15 mg H₂O₂/g TS improved the digester mixing conditions, resulting in enhanced mass transfer during digestion of dewatered WAS under non-ideal mixing conditions.

In addition, Figure 4.6b shows an asymmetric allocation of error between different treatments in the AMPTS-II: the pre-treated samples had evidently higher standard deviations between the replicates compared with the non-treated samples. We speculate that the lower viscosity brought about by H₂O₂ made the liquor more susceptible to the variations in mixing energy from each individual AMPTS-II's motors. Moreover, any possible small difference was probably magnified since the samples were digested for 25 days. Overall, this was not the case for the orbital oscillator, which delivers the same mixing energy to all the liquors (at least conceptually).

Considering that many pilot and full-scale AD reactors are non-ideally mixed (Dapelo and Bridgeman, 2018; Wei, 2021), our present results might explain the observations done in our pilot-scale experiment, performed at similar pre-treatment settings (Gonzalez et al., 2020). In that study, pre-treatment at 70 °C with 15 mg H₂O₂/g TS, preceding compartmentalized digestion, allowed for an increase in organic loading rate from 1.4 to 4.1 kg VS/m³d, without process impairment and even with a slight increase in biogas production (from 425 to 486 L/kg VS) and volatile solids degradation (from 40 to 44%, in absolute values). The observed increase in methane production, might be attributed to a decrease in WAS viscosity, improved mixing and enhanced mass transfer, which also coincides with the conclusion drawn by Liu et al. (2020) in a lab-scale scenario. Nonetheless, mass transfer and enhanced biochemical conversion are interrelated and were not studied as separated variables in the present study.

4.3.5 Possible reasons explaining the viscosity drop

4.3.5.1 Particle size distribution (PSD)

Changes in PSD and floc disintegration are factors that influence the apparent viscosity of biological sludge (Pevere et al., 2009; Yuan et al., 2011). While Figure S4-14 shows a clear decrease in the size of particles due to the thermal effect (which seemed proportional to exposure time), no obvious additional decrease was caused by the addition of H₂O₂. Thus, the observed decrease in viscosity generated by H₂O₂ was apparently not related to changes in the average particle size of WAS.

4.3.5.2 Oxidative stress: Fenton's reagent

Previous studies have suggested that the effects of H₂O₂ are related to the formation of oxidative species (See Section 1). The Fenton's reagent consists of the production of hydroxyl radicals (HO·) from H₂O₂, a reaction that is catalyzed by ferrous iron (Fe²⁺) (Equation 5) and its occurrence is possible at neutral pH values (Wu et al., 2020).

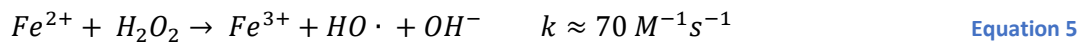

Thus, it was tested if the Fenton's reagent could cause the observed decrease in WAS viscosity. Based on Equation 5 and assuming that the entire pool of iron in WAS is ferrous and accessible for H₂O₂ (27.7 ± 3.9 mg Fe/g TS, n=3, obtained via solubilization of the WAS matrix with digestion at 300 °C with 30% HNO₃ and subsequent ICP-OES analysis), a theoretical concentration of ~7.5 mg HO·/g TS (~35 mM) was calculated. Thus, quantitatively, the possible presence of HO· during pre-treatment could explain the observed changes in rheology. Figure 4.7a shows the concentration of 2-hydroxyterephthalate (2hTA, which is expected to be analogous to the concentration of HO·, see Section 2.3.5) during pre-treatment of WAS. The result suggests that only 0.05 % of the theoretical HO· were produced. Such a low yield could be explained by the Pourbaix diagram in Figure S4-15: in the pre-treatment conditions (pH > 5.5; ORP > 0; T~70 °C) the dominant iron species is expected to be iron (III) oxide. Iron (III) oxides contain ferric iron (Fe³⁺), which would result in a slower chemical pathway, as shown in Equation 6:

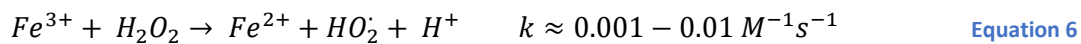

Nonetheless, even a micromolar concentration of HO· suffices to provoke alterations in the physicochemical properties of proteins (Davies, 2016; Stadtman, 2001; Zhang et al., 2013), which are the most abundant organic compounds in WAS (Xu et al., 2018). A possible relationship between the production of HO· and the decrease in shear stress of sludge was assessed: Tannic acid (TA), an iron chelator (Lopes et al., 1999; Phiwchai et al., 2018), was added to WAS in a TA:Fe molar ratio of 1.5:1 to inhibit the production of HO· (Equation 5). As tannic acid resulted in a pH decrease of ~1 pH unit, control samples were spiked with 30 % HCl to compensate for this pH drop and the resulting samples were then analyzed with fluorimetry and rheometry. Figure 4.7a demonstrates that tannic acid successfully inhibited the formation of 2hTA, suggesting that the Fenton's reagent was suppressed. However, despite the absence of 2hTA, the decrease in shear stress persisted when H₂O₂ was added (Figure 4.7b), implying that the decrease in viscosity and the formation of HO· were unrelated (Figure 4.7a). Notably, the addition of TA increased the shear stress (Figure 4.7b), which was partly counteracted by adding H₂O₂.

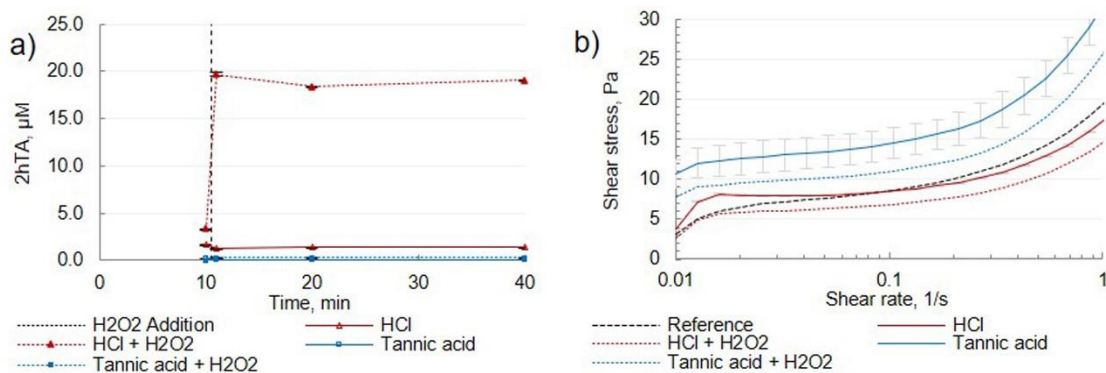

Figure 4.7 a) concentration of 2hTA during pre-treatment in different conditions; b) shear rate vs shear stress curves of the pre-treated samples, n=3.

4.3.5.3 Oxidative stress: H_2O_2

The reaction between H_2O_2 and the components of WAS (Figure 4.2) might be another cause of the decrease in shear stress. Compared to $HO\cdot$, H_2O_2 has a lower oxidizing potential but also higher stability (Davies, 2016; Zhang et al., 2013).

In the food science field, the combination of H_2O_2 with cationic polymers was found to increase the biocidal properties of peroxide (Rios-Castillo et al., 2017). As the WAS samples contained a cationic polymer, mixed liquor from the secondary settler was centrifuged without the use of polymer to a concentration of solids similar to the dewatered WAS with polymer. Both samples were then pre-treated and their shear stress compared. The results demonstrated that the addition of polymer was not the reason of the decrease in viscosity (Figure S4-16).

However, H_2O_2 has also been demonstrated to affect specific functional groups (Wu et al., 2017): Studies from the agricultural and pharmaceutical fields proved the ability of H_2O_2 to cleave the glycosidic bonds of several polysaccharides (Dahl et al., 1998; Miller, 1986; Qin et al., 2002). Specifically, Miller (1986) demonstrated that the depolymerization caused by H_2O_2 resulted in a decrease in viscosity of a solution made of carbohydrates. An additional experiment validated this result using the pre-treatment conditions employed in the present study and solutions of collagen, humic acid sodium salt, and cellulose as model molecules for protein, humic substances, and carbohydrates (Figure S4-17), which are known to be some of the most abundant organic constituents in WAS. Among them, cellulose not only had the highest viscosity (almost 3 orders of magnitude higher than the other solutions) but also was the only one that decreased its viscosity as a result of H_2O_2 addition. Thus, despite the low concentration of carbohydrates in WAS (A. Gonzalez et al., 2018), it is possible that the alteration of the molecular structure of the polysaccharides in WAS could also modify its rheology.

4.3.6 Implication

Lab-scale validation of computational fluid dynamics (CFD) models have implied an inversely proportional relation between the velocity of the particles in the digesters and the viscosity of the reactor liquor (Bridgeman, 2012; Liu et al., 2018). Liquid or sludge viscosity affects the amount of energy required to produce turbulence and to avoid dead-zones in full-scale digesters (Bridgeman, 2012; Liu et al., 2018; Wei, 2021). Since at least some rheological properties of the substrate are correlated with the properties of the digestate (Liu et al., 2016; Miryahaeyi et al., 2019)(Figure S4-13), a decreased yield stress of the sludge might imply less dead-zones in full scale systems.

In the present study, the use of convectional heat at 70 °C and a low dose of H₂O₂ (0.5-3% w/w), resulted in a decrease in the apparent viscosity of concentrated WAS, resulting in a more fluid sludge stream. Thus, it is considered that pre-treatment conditions are a possible strategy to increase the methane production rate of full-scale anaerobic digesters via a drop in apparent viscosity of WAS.

4.4 Conclusions

The results presented in this study showed that the combination of heating at 70 °C with the addition of H₂O₂ resulted in the increase in the methane production rate in non-ideally mixed anaerobic digestion. The following mechanisms were proposed to explain the phenomenon: Firstly, thermal pre-treatment at 70 °C deactivated catalase and promoted the accessibility of EPS. Thermal pre-treatment at 70 °C also increased the reaction rate of H₂O₂, which in turn lowered the apparent viscosity of WAS in the range between 5-30 mg H₂O₂/g TS. The decrease in viscosity of pre-treated WAS allowed a slight increase in methane production rate under non-ideal mixing conditions during anaerobic digestion.

The Fenton's reagent and the presence of conditioning agent (cationic polymer) were not related to the observed modifications in rheology. The pre-treatment conditions applied in this study might be used as a strategy to increase methane production in full-scale WAS digesters, without increasing the mixing power requirement.

4.5 References

- Ambrose, H.W., Chin, C.T.L., Hong, E., Philip, L., Suraishkumar, G.K., Sen, T.K., Khiadani, M., 2020. Effect of hybrid (microwave-H₂O₂) feed sludge pretreatment on single and two-stage anaerobic digestion efficiency of real mixed sewage sludge. *Process Saf. Environ. Prot.* 136, 194–202. <https://doi.org/10.1016/j.psep.2020.01.032>
- AntonPaar, 2021. Basics of rheology [WWW Document]. URL <https://wiki.anton-paar.com/en/basics-of-rheology/> (accessed 7.7.21).
- Bridgeman, J., 2012. Computational fluid dynamics modelling of sewage sludge mixing in an anaerobic digester. *Adv. Eng. Softw.* 44, 54–62. <https://doi.org/10.1016/j.advengsoft.2011.05.037>
- Charbouillot, T., Brigante, M., Mailhot, G., Reddy, P., Minero, C., Vione, D., 2011. Performance and selectivity of the terephthalic acid probe for •OH as a function of temperature, pH and composition of atmospherically relevant aqueous media. *J. Photochem. Photobiol. A Chem.* 222, 70–76. <https://doi.org/10.1016/j.jphotochem.2011.05.003>
- Dahl, T., He, G.-X., Samuels, G., 1998. Effect of hydrogen peroxide on the viscosity of a hydroxyethylcellulose-based gel. *Pharm. Res.* 15, 1137–1140. <https://doi.org/10.1023/a:1011958901154>
- Dapelo, D., Bridgeman, J., 2018. Euler-Lagrange computational fluid dynamics simulation of a full-scale unconfined anaerobic digester for wastewater sludge treatment. *Adv. Eng. Softw.* 117, 153–169. <https://doi.org/10.1016/j.advengsoft.2017.08.009>
- Davies, M.J., 2016. Protein oxidation and peroxidation. *Biochem. J.* 473, 805–825. <https://doi.org/10.1042/BJ20151227>
- Doskočil, L., Grasset, L., Válková, D., Pekař, M., 2014. Hydrogen peroxide oxidation of humic acids and lignite. *Fuel* 134, 406–413. <https://doi.org/10.1016/j.fuel.2014.06.011>
- Eskicioglu, C., Prorot, A., Marin, J., Droste, R.L., Kennedy, K.J., 2008. Synergetic pretreatment of sewage sludge by microwave irradiation in presence of H₂O₂ for enhanced anaerobic digestion. *Water Res.* 42, 4674–4682. <https://doi.org/10.1016/j.watres.2008.08.010>
- Eskicioglu, C., Terzian, N., Kennedy, K.J., Droste, R.L., Hamoda, M., 2007. Athermal microwave effects for enhancing digestibility of waste activated sludge. *Water Res.* 41, 2457–2466. <https://doi.org/10.1016/j.watres.2007.03.008>
- Eyster, H.C., 1950. Effect of temperature on catalase activity 273–277.
- Fang, X., Mark, G., von Sonntag, C., 1996. OH radical formation by ultrasound in aqueous solutions Part I: the chemistry underlying the terephthalate dosimeter. *Ultrason. Sonochem.* 3, 57–63. [https://doi.org/https://doi.org/10.1016/1350-4177\(95\)00032-1](https://doi.org/https://doi.org/10.1016/1350-4177(95)00032-1)
- Gan, P.P., Li, S.F.Y., 2013. Efficient removal of Rhodamine B using a rice hull-based silica supported iron catalyst by Fenton-like process. *Chem. Eng. J.* 229, 351–363. <https://doi.org/10.1016/j.cej.2013.06.020>
- Gonzalez, A., Guo, H., Ortega-Ibáñez, O., Petri, C., van Lier, J.B., de Kreuk, M., Hendriks, A., 2020. Mild thermal pre-treatment of waste activated sludge to increase loading capacity, biogas production, and solids' degradation: A pilot-scale study. *Energies* 13, 6059. <https://doi.org/10.3390/en13226059>
- Gonzalez, A., Hendriks, A.T.W.M., van Lier, J.B., de Kreuk, M., 2018. Pre-treatments to enhance the biodegradability of waste activated sludge: Elucidating the rate limiting step. *Biotechnol. Adv.* 36, 1434–1469. <https://doi.org/10.1016/j.biotechadv.2018.06.001>
- Gonzalez, A., Lier, J.B. Van, Kreuk, M.K. De, 2021. The role of growth media on composition, bioconversion and susceptibility for mild thermal pre-treatment of waste activated sludge. *J. Environ. Manage.* 298, 113491. <https://doi.org/10.1016/j.jenvman.2021.113491>
- Gonzalez, D., Kuang, X.M., Scott, J.A., Rocha, G.O., Paulson, S.E., Gonzalez, D.H., Kuang, X.M., Scott, J.A.,

- Olimpio, G., 2018. Terephthalate probe for hydroxyl radicals: yield of 2-hydroxyterephthalic acid and transition metal interference. *Anal. Lett.* 51, 2488–2497.
<https://doi.org/10.1080/00032719.2018.1431246>
- Hafner, S., Fruteau, H., Koch, K., Holliger, C., 2020. Improving inter-laboratory reproducibility in measurement of biochemical methane potential (BMP). *Water* 12.
<https://doi.org/10.3390/w12061752>
- Hammadi, L., Ponton, A., Belhadri, M., 2012. Effects of heat treatment and hydrogen peroxide (H₂O₂) on the physicochemical and rheological behavior of an activated sludge from a water purification plant. *Procedia Eng.* 33, 293–302. <https://doi.org/10.1016/j.proeng.2012.01.1207>
- Iwase, T., Tajima, A., Sugimoto, S., Okuda, K., Hironaka, I., Kamata, Y., 2013. A simple assay for measuring catalase activity: a visual approach. *Sci. Rep.* 3, 3–6. <https://doi.org/10.1038/srep03081>
- Le, N.T., Julcour-Lebigue, C., Delmas, H., 2015. An executive review of sludge pretreatment by sonication. *J. Environ. Sci. (China)* 37, 139–153. <https://doi.org/10.1016/j.jes.2015.05.031>
- Liang, J., Zhang, S., Huang, J., Ye, M., Yang, X., Huang, S., Sun, S., 2020. Mechanism of zero valent iron and anaerobic mesophilic digestion combined with hydrogen peroxide pretreatment to enhance sludge dewaterability: relationship between soluble EPS and rheological behavior. *Chemosphere* 247, 125859. <https://doi.org/10.1016/j.chemosphere.2020.125859>
- Liu, J., Jia, R., Wang, Y., Wei, Y., Zhang, J., Wang, R., Cai, X., 2015. Does residual H₂O₂ result in inhibitory effect on enhanced anaerobic digestion of sludge pretreated by microwave-H₂O₂ pretreatment process? *Environ. Sci. Pollut. Res.* 9016–9025. <https://doi.org/10.1007/s11356-015-5704-z>
- Liu, J., Yang, M., Zhang, J., Zheng, J., Xu, H., Wang, Y., 2018. A comprehensive insight into the effects of microwave-H₂O₂ pretreatment on concentrated sewage sludge anaerobic digestion based on semi-continuous operation. *Bioresour. Technol.* 256, 118–127.
<https://doi.org/10.1016/j.biortech.2018.01.126>
- Liu, J., Yu, D., Zhang, J., Yang, M., Wang, Y., Wei, Y., Tong, J., 2016. Rheological properties of sewage sludge during enhanced anaerobic digestion with microwave-H₂O₂ pretreatment. *Water Res.* 98, 98–108. <https://doi.org/10.1016/j.watres.2016.03.073>
- Liu, J., Zheng, J., Zhang, J., Yu, D., Wei, Y., 2020. The performance evaluation and kinetics response of advanced anaerobic digestion for sewage sludge under different SRT during semi-continuous operation. *Bioresour. Technol.* 308, 123239. <https://doi.org/10.1016/j.biortech.2020.123239>
- Lopes, G.K.B., Schulman, H.M., Hermes-Lima, M., 1999. Polyphenol tannic acid inhibits hydroxyl radical formation from Fenton reaction by complexing ferrous ions. *Biochim. Biophys. Acta* 1472, 142–152.
[https://doi.org/https://doi.org/10.1016/S0304-4165\(99\)00117-8](https://doi.org/https://doi.org/10.1016/S0304-4165(99)00117-8)
- Miller, A.R., 1986. Oxidation of cell wall polysaccharides by hydrogen peroxide: A potential mechanism for cell wall breakdown in plants. *Biochem. Biophys. Res. Commun.* 141, 238–244.
[https://doi.org/10.1016/S0006-291X\(86\)80359-X](https://doi.org/10.1016/S0006-291X(86)80359-X)
- Miryahyaei, S., Olinga, K., Abdul Muthalib, F.A., Das, T., Ab Aziz, M.S., Othman, M., Baudez, J.C., Batstone, D., Eshtiaghi, N., 2019. Impact of rheological properties of substrate on anaerobic digestion and digestate dewaterability: New insights through rheological and physico-chemical interaction. *Water Res.* 150, 56–67. <https://doi.org/10.1016/j.watres.2018.11.049>
- Neumann, P., Pesante, S., Venegas, M., Vidal, G., 2016. Developments in pre-treatment methods to improve anaerobic digestion of sewage sludge. *Rev. Environ. Sci. Biotechnol.* 15, 173–211.
<https://doi.org/10.1007/s11157-016-9396-8>
- Pevere, A., Guibaud, G., Goin, E., van Hullebusch, E., Lens, P., 2009. Effects of physico-chemical factors on the viscosity evolution of anaerobic granular sludge. *Biochem. Eng. J.* 43, 231–238.
<https://doi.org/10.1016/j.bej.2008.10.003>
- Phiwchai, I., Yuensook, W., Sawaengsriphon, N., Krungchanuchat, S., Pilapong, C., 2018. Tannic acid (TA): A molecular tool for chelating and imaging labile iron. *Eur. J. Pharm. Sci.* 114, 64–73.

- <https://doi.org/10.1016/j.ejps.2017.12.004>
- Pignatello, J.J., Oliveros, E., MacKay, A., 2006. Advanced oxidation processes for organic contaminant destruction based on the Fenton reaction and related chemistry. *Crit. Rev. Environ. Sci. Technol.* 36, 1–84. <https://doi.org/10.1080/10643380500326564>
- Pilli, S., Bhunia, P., Yan, S., LeBlanc, R.J., Tyagi, R.D., Surampalli, R.Y., 2011. Ultrasonic pretreatment of sludge: a review. *Ultrason. Sonochem.* 18, 1–18. <https://doi.org/10.1016/j.ultsonch.2010.02.014>
- Pilli, S., Yan, S., Tyagi, R.D., Surampalli, R.Y., 2014. Thermal pretreatment of sewage sludge to enhance anaerobic digestion: A review. *Crit. Rev. Environ. Sci. Technol.* 45, 669–702. <https://doi.org/10.1080/10643389.2013.876527>
- Qin, C.Q., Du, Y.M., Xiao, L., 2002. Effect of hydrogen peroxide treatment on the molecular weight and structure of chitosan. *Polym. Degrad. Stab.* 76, 211–218. [https://doi.org/10.1016/S0141-3910\(02\)00016-2](https://doi.org/10.1016/S0141-3910(02)00016-2)
- Ratkovich, N., Horn, W., Helmus, F.P., Rosenberger, S., Naessens, W., Nopens, I., Bentzen, T.R., 2012. Activated sludge rheology: A critical review on data collection and modelling. *Water Res.* 47, 463–482. <https://doi.org/10.1016/j.watres.2012.11.021>
- Rios-Castillo, A.G., Gonzalez-Rivas, F., J., R.-J.J., 2017. Bactericidal efficacy of hydrogen peroxide-based disinfectants against gram-positive and gram-negative bacteria on stainless steel surfaces. *Food Microbiol. Saf.* 82, 2351–2356. <https://doi.org/10.1111/1750-3841.13790>
- Samstag, R.W., Ducoste, J.J., Griborio, A., Nopens, I., Batstone, D.J., Wicks, J.D., Saunders, S., Wicklein, E.A., Kenny, G., Laurent, J., 2016. CFD for wastewater treatment: An overview. *Water Sci. Technol.* 74, 549–563. <https://doi.org/10.2166/wst.2016.249>
- Stadtman, E.R., 2001. Protein oxidation in aging and age-related diseases. *Ann. N. Y. Acad. Sci.* 928, 22–38. <https://doi.org/10.1111/j.1749-6632.2001.tb05632.x>
- Velayati, A.A., Farnia, P., Saif, S., 2019. Identification of nontuberculous Mycobacterium: Conventional versus rapid molecular tests, in: *Nontuberculous Mycobacteria (NTM)*. Elsevier Inc., pp. 11–59. <https://doi.org/10.1016/B978-0-12-814692-7.00002-4>
- Wang, Y., Wei, Y., Liu, J., 2009. Effect of H₂O₂ dosing strategy on sludge pretreatment by microwave-H₂O₂ advanced oxidation process. *J. Hazard. Mater.* 169, 680–684. <https://doi.org/10.1016/j.jhazmat.2009.04.001>
- Wei, P., 2021. Characterisation of Sludge Rheology and Sludge Mixing in Gas-mixed Anaerobic Digesters. Delft University of Technology.
- Wei, P., Mudde, R.F., Uijtewaal, W., Spanjers, H., van Lier, J.B., de Kreuk, M., 2019. Characterising the two-phase flow and mixing performance in a gas-mixed anaerobic digester: Importance for scaled-up applications. *Water Res.* 149, 86–97. <https://doi.org/10.1016/j.watres.2018.10.077>
- Wei, P., Tan, Q., Uijtewaal, W., Lier, J.B. Van, Kreuk, M. De, 2018. Experimental and mathematical characterisation of the rheological instability of concentrated waste activated sludge subject to anaerobic digestion. *Chem. Eng. J.* 349, 318–326. <https://doi.org/10.1016/j.cej.2018.04.108>
- Wei, P., Uijtewaal, W., van Lier, J.B., de Kreuk, M., 2021. Impacts of shearing and temperature on sewage sludge: Rheological characterisation and integration to flow assessment. *Sci. Total Environ.* 774, 145005. <https://doi.org/10.1016/j.scitotenv.2021.145005>
- Wu, B., Dai, X., Chai, X., 2020. Critical review on dewatering of sewage sludge: Influential mechanism, conditioning technologies and implications to sludge re-utilizations. *Water Res.* 180, 115912. <https://doi.org/10.1016/j.watres.2020.115912>
- Wu, B., Ni, B., Horvat, K., Song, L., Chai, X., Dai, X., Mahajan, D., 2017. Occurrence state and molecular structure analysis of extracellular proteins with implications on the dewaterability of waste-activated sludge. *Environ. Sci. Technol.* 51, 9235–9243. <https://doi.org/10.1021/acs.est.7b02861>
- Wu, D., Qian, X., 2018. Experimental study on the thermal runaway of hydrogen peroxide with in-/organic impurities by a batch reactor. *J. Loss Prev. Process Ind.* 51, 200–207.

<https://doi.org/10.1016/j.jlp.2017.12.012>

- Xiao, Q., Yan, H., Wei, Y., Wang, Y., Zeng, F., Zheng, X., 2012. Optimization of H₂O₂ dosage in microwave-H₂O₂ process for sludge pretreatment with uniform design method. *J. Environ. Sci. (China)* 24, 2060–2067. [https://doi.org/10.1016/S1001-0742\(11\)60998-4](https://doi.org/10.1016/S1001-0742(11)60998-4)
- Xu, Q., Wang, Q., Zhang, W., Yang, P., Du, Y., Wang, D., 2018. Highly effective enhancement of waste activated sludge dewaterability by altering proteins properties using methanol solution coupled with inorganic coagulants. *Water Res.* 138, 181–191. <https://doi.org/10.1016/j.watres.2018.03.038>
- Yu, W., Yang, J., Shi, Yafei, Song, J., Shi, Yao, Xiao, J., Li, C., Xu, X., He, S., Liang, S., Wu, X., Hu, J., 2016. Roles of iron species and pH optimization on sewage sludge conditioning with Fenton's reagent and lime. *Water Res.* 95, 124–133. <https://doi.org/10.1016/j.watres.2016.03.016>
- Yuan, H., Yan, X., Yang, C., Zhu, N., 2011. Enhancement of waste activated sludge dewaterability by electro-chemical pretreatment. *J. Hazard. Mater.* 187, 82–88. <https://doi.org/10.1016/j.jhazmat.2010.12.106>
- Zhang, W., Xiao, S., Ahn, D.U., 2013. Protein Oxidation: Basic Principles and Implications for Meat Quality. *Crit. Rev. Food Sci. Nutr.* 53, 1191–1201. <https://doi.org/10.1080/10408398.2011.577540>
- Zhen, G., Wang, J., Lu, X., Su, L., Zhu, X., Zhou, T., Zhao, Y., 2019. Effective gel-like floc matrix destruction and water seepage for enhancing waste activated sludge dewaterability under hybrid microwave-initiated Fe(II)-persulfate oxidation process. *Chemosphere* 221, 141–153. <https://doi.org/10.1016/j.chemosphere.2019.01.037>

Chapter 5. *Vadere*: ‘Bricklaying’ activated sludge and the effect of sludge composition in pre-treatment performance.

This chapter is based on:

Gonzalez, A., Lier, J.B. Van, Kreuk, M.K. De, 2021. The role of growth media on composition, bioconversion and susceptibility for mild thermal pre-treatment of waste activated sludge. *J. Environ. Manage.* 298, 113491. <https://doi.org/10.1016/j.jenvman.2021.113491>

Abstract

The highly variable characteristics of waste activated sludge (WAS) hinder the comparison of experimental results on WAS bioconversion between the different studies that use excess sludge from different origin. Sludge grown under laboratory conditions with synthetic wastewater as feed showed high resistance to commonly applied pre-treatment techniques, such as thermal pre-treatment. However, a distinctly higher bioconversion of this sludge was recorded compared to WAS from a full-scale wastewater treatment plant (WWTP). The observed results casted concern on the suitability of the experimental laboratory-based data for practice. The physicochemical and biochemical characteristics of both WAS and lab-grown sludge are dependent on the wastewater characteristics or growth media on which the sludges were grown. The objective of this study was to formulate a growth medium that results into a lab-grown sludge which shows high similarity to the WAS coming from a specific full-scale WWTP in response to a pre-treatment technique. More specifically, in this study we targeted the formation of slowly-biodegradable lab-grown sludge that is similarly responsive to mild thermal pre-treatment with H₂O₂ addition. By comparing real and synthetic wastewaters, we discussed the various wastewater constituents that may lead to a higher degree of recalcitrance of the produced sludge. We then formulated a growth medium, which was fed to a lab-scale activated sludge reactor and evaluated the nutrient removal capacity, as well as the characteristics of the cultivated sludge before and after pre-treatment. Finally, the growth medium was modified to provoke a change in both the bioconversion and in the response to mild thermal pre-treatment. The growth medium proposed in this study resulted in a slowly-biodegradable sludge (195 ± 3.7 NLCH₄/kgVS_{added}) that after thermal pre-treatment resulted in an increase in methane production of 9%, which was similar to the WAS coming from the full-scale WWTP. It was concluded that not only the bioconversion but also the response to mild thermal pre-treatment of lab-grown sludge was determined by the composition of the growth media.

Keywords: activated sludge; anaerobic digestion; domestic wastewater; lab-grown sludge; pre-treatment; synthetic wastewater.

5.1 Introduction

Waste activated sludge (WAS) is the most abundant by-product of conventional activated sludge (CAS) wastewater treatment plants (WWTP) for municipal sewage: a biological matrix composed of microbes, metals and countless unknown organic and inert materials (Tchobanoglous et al., 2003). Anaerobic digestion is commonly applied to biodegrade WAS and extensive research has been conducted to maximize its methane production during digestion via pre-treatment methods (Neumann et al., 2016; Pilli et al., 2014).

Nonetheless, the high variability in sewage characteristics and applied CAS systems usually results into unpredictable composition and characteristics of WAS, casting concern on the reproducibility of lab-scale WAS pre-treatment experiments and limiting the insight on mechanisms underlying the effect of these pre-treatment methods (Gonzalez et al., 2020; Ruffino et al., 2019b; Xu et al., 2020). In fact, a systematic comparison between the different WAS pre-treatment techniques demands the availability of sludge with defined non-variable characteristics with a high similarity in physicochemical and biochemical properties with WAS from a full-scale CAS system. For this reason, various researchers cultivated lab-grown sludge that, however, differed substantially in composition and characteristics (Dai et al., 2017c; Xu et al., 2017). In particular, lab-based experimental results have demonstrated that pre-treated sludge, cultivated with synthetic wastewater, did not result into an increment in bioconversion similarly as observed for WAS from full scale WWTPs. Since the studied pre-treatment methods generally increase the WAS bioconversion from full scale WWTPs (Gonzalez et al., 2020; Pilli et al., 2014), it was hypothesized that the inherently high bioconversion of the lab-grown sludge severely masked the effectiveness of pre-treatment.

Recent research, clearly showed that the composition of the synthetic wastewater that was used to cultivate the lab-grown sludge, distinctly impacted the characteristics of resulting sludge, although studies addressing the effects on biodegradation are rather scarce (Dai et al., 2017c; Layer et al., 2019; Li et al., 2012; B. Wang et al., 2018; Xu et al., 2017). Similarly, physicochemical reactions, such as complexation, between some of the components of the wastewater during the formation of sludge, may possibly result in a reduced biodegradation of WAS (Xu et al., 2020). Such reactions might not occur when simple synthetic influents are used to grow the biomass in laboratory experiments.

Considering the above, we consider that, thus far, the used synthetic wastewaters were not suitable for producing lab-grown sludge with a similar recalcitrant organic matrix, leading to non-predictive results of novel WAS pre-treatment techniques. The objective of the present study is to propose and evaluate a new growth medium to produce lab-grown sludge that behaves similarly to WAS from a full-scale CAS system with respect to low-temperature pre-treatment and subsequent anaerobic digestion. In this manuscript, low-temperature pre-treatment refers to the exposure of sludge to 70 °C plus 15 mg H₂O₂/g TS.

5.2 Materials and methods

The following research approach was adopted: Firstly, municipal wastewater from 3 CAS systems in The Netherlands were analyzed and their characteristics were used as a baseline for the comparison with several synthetic wastewater recipes that are used in published studies (Aiyuk and Verstraete, 2004; Martín et al., 2010; Ozgun et al., 2013; Xu et al., 2017). Secondly, the rationale behind the composition of the proposed synthetic wastewater (SWW-1) was discussed. Thirdly, the growth medium SWW-1 was

fed to a lab-scale activated sludge reactor. The performance of the biological nutrient removal was monitored and the characteristics of the resulting cultivated sludge were compared to those of WAS. (In this manuscript, WAS refers to sludge from the WWTP, while lab-grown is sludge cultivated under controlled conditions.) Finally, a modified version of the proposed synthetic wastewater (SWW-2) was fed to the reactor to induce a change in the response of pre-treatment and provide insight on its mode of action. Details on each step are provided next.

5.2.1 Wastewater and liquors sampling

Samples of settled domestic wastewater and mixed liquors from the aeration tanks were collected from three wastewater treatment plants in The Netherlands: Harnaspolder, in Den Hoorn (GPS 52.013372, 4.317284); Nieuwgraaf, in Arnhem (GPS 51.973766, 6.000757); and Kralingseveer, in Rotterdam (GPS 51.907063, 4.542640). The collection of samples occurred in January and February and Kralingseveer wastewater treatment plant (WWTP) had rainy weather the day before sampling, while the other samples were taken during several days during dry weather condition. The aliquots were then transported to the laboratory within 3 h and stored at 4 °C. All analyses were performed within 36 h of sampling.

5.2.2 Analytics

COD, solids, VFA, ORP and pH. Total solids (TS); volatile solids (VS); chemical oxygen demand (COD); and volatile fatty acids (VFA) were measured as described in Gonzalez et al. (2020). pH was measured with a SenTix 940 IDS probe and data was recorded with a multimeter model 3620 IDS (Xylem Inc, U.S.A.). Conductivity was measured with a TetraCon325 probe and retrieved with a multimeter InoLab® Multi 9620 IDS (Xylem Inc, U.S.A.). Sludge volume index (SVI) was determined using a 1-L Imhoff cone after 30 min of settling based on method 2710D (APHA et al., 2017). Similarly, settleable solids were measured based on method 2540F, while total and volatile suspended solids (TSS and VSS) with method 2540D and E, respectively (APHA et al., 2017). The sample volume for TSS and VSS of wastewater and synthetic wastewater was 40 mL and the samples were filtered through glassfiber filters AP4007000 from (Merck KGaA, Germany) with a nominal pore size of 0.7 µm. A variety of analytical assays were performed using the Hach LCK cuvette test system (Table S5-1) and were read with a photometer DR 3900 (Hach, U.S.A.).

Extracellular polymeric substances (EPS) extraction. EPS extraction was based on the method from Liu et al. (2016). 50 g of sludge diluted at 1:5 with a 0.05 % NaCl (w/v) solution at 70 °C were centrifuged at 15000 g for 15 min at 4 °C in a centrifuge model Sorvall ST 16 (Thermo Fisher Scientific, U.S.A.). The supernatant was recovered as the soluble fraction of EPS (S-EPS). The resulting precipitate was resuspended with the saline solution until the total mass of liquor was 50 g. The assay tube was centrifuged again in the same conditions as above and the liquid fraction was retrieved as the lightly bound fraction (LB-EPS). The settled contents in the tube were suspended once more with saline solution at 60 °C. The resulting liquor was mixed with a magnetic stirrer for 30 min at 60 °C. Finally, the heated sample was centrifuged at the mentioned conditions and the supernatant was collected as the tightly bound fraction (TB-EPS). The three EPS fractions were filtered through a polytetrafluoroethylene (PTFE) filter with a pore size of 0.45 µm (Macherey-Nagel GmbH & Co, Düren, Germany). The precipitate obtained after the collection of the TB-EPS, was considered as the pellet fraction.

EPS composition. Analyses of protein, humic substances and polysaccharides were performed as shown in Zhen et al. (2019). The standard substrates were bovine serum albumin (BSA); humic acid sodium salt;

and D-(+)-glucose, respectively. All the chemical reagents required for determination of EPS were obtained from Sigma (Sigma-Aldrich, U.S.A), except 98 % H₂SO₄, which was obtained from Carl Roth (Carl Roth GmbH & Co KG, Germany).

Inductively Coupled Plasma Optical Emission Spectrometry (ICP-OES). The preparation of the sample for measuring the concentration of Al; B; Ca; Co; Cr; Cu; Fe; K; Mg; Mn; Mo; Na; Ni; W; and Zn in wastewater, synthetic wastewater and mixed liquor proceeded as follows: 100 mL of sample were filtered through a 200 µm sieve. Approximately 9 mL of the filtered sample were acidified in 4.5 mL of 30 % HCl and 1.5 mL of 65 % HNO₃ and heated up in a microwave digester model Multiwave PRO (Aanton Paar, Austria) for 1 h at 300 °C to solubilize the contents. ICP-OES was performed to the digested sample with a spectrometer model Optima 5300DV (Perkin Elmer, U.S.A.) using a sapphire injector and a glass nebulizer. Silicon (Si) was not measured due to problems in acid solubilization. In some samples, Cu and Mn had concentrations with considerable differences compared to the stoichiometric value and interference(s) with other element or compound was suspected (Ranjbar et al., 2012; Shoaee et al., 2012). Thus, for Cu and Mn both the measured and stoichiometric concentrations are presented.

Specific methane production (SMP) and methane production rate (k_{CH_4}). SMP and k_{CH_4} were determined as described previously (Gonzalez et al., 2020). Bottles with a working volume of 800 mL were agitated with an oscillatory incubator shaker model Innova 44 (Eppendorf, Germany) at a rotational speed of 120 rpm at 35 °C. The produced biogas was scrubbed with 160 mL of a 3 M NaOH solution and the gas was measured in a gas volume measuring device (BPC, Sweden). Physicochemical characteristics of the sludge samples used for SMP are detailed in Table S5-2. Thickened WAS was obtained from Kralingseveer WWTP and used as reference. Lab-grown sludge from the sequencing batch reactor (SBR) was collected at several times. The liquor was centrifuged to a concentration of solids similar to the dewatered WAS with a centrifuge model Labofuge 400 (Thermo Fisher Scientific, U.S.A) at 3500 RCF for 8 min without the addition of conditioning agents. The inoculum for the SMP tests was obtained from the anaerobic digester of Harnaschpolder WWTP which was operated with a retention time of ~21 days at 37 °C and was collected approximately 1 week before the start of each test. Digestate was sieved through a 0.7 mm sieve and pre-incubated between 4-7 days at 35 °C.

Biological oxygen demand (BOD). BOD was determined with a respirometer Oxitop OC100 controller and Oxitop-C measuring heads (Xylem Inc, U.S.A.) with a detection range of 0-400 mg/L. Around 1 L of sample was saturated with oxygen and diluted to a COD ≈300 mg/L. 164 mL of the prepared aliquots were added to 3 borosilicate bottles with a working volume of 250 mL. Blank samples in the range of 0-40 mg/L and with a working volume 432 mL were assayed to account for the BOD of the inoculum. Stirring rods were included in each bottle to ensure mixing during the whole assay. Neither nutrient or buffer solutions were added and each bottle was inoculated with 9 mg VSS of activated sludge from the aeration tank of Harnaschpolder WWTP. N-Allylthiourea (Sigma-Aldrich, U.S.A) was used as nitrification inhibitor, thus, the obtained BOD value corresponded to the carbonaceous BOD at the 5th day (CBOD₅). Finally, 2 pellets of NaOH were added in a separated compartment inside the bottle and then the bottle was sealed with a measuring head. The variation in partial pressure in the bottle caused by the production of CO₂ were detected by the measuring heads and a data point was taken every 20 min and retrieved via ACHAT OC Software (Xylem Inc, U.S.A.). The initial concentration of dissolved oxygen (DO) was around 8 mg/L and the final value was around 4-5 mg/L. The temperature was kept in the range 20-21 °C along the assay. The COD of the prepared liquors was also measured at the beginning and end of

the test to corroborate the data from the respirometer. BOD values of domestic wastewater were obtained from the process operators of the WWTPs.

Miscellaneous methods. Particle size distribution (PSD), was measured with a laser diffraction instrument model Microtrac MRB's Bluewave (Microtrac Retsch GmbH, Germany): The sludge was diluted 1:5 with a solution of 0.05 % NaCl (w/v) and 2 mL of the resulting solution were analyzed. Turbidity was measured with a Hach 2100N turbidimeter (Hach, U.S.A). Alkalinity was determined via titration with 0.1 M HCl using a volumetric titration system Titrino SM 702, Metrohm (Metrohm AG, Switzerland): 100 mL of sample were dispensed and mixed with a magnetic stirrer and the amount to acid to reach a pH of 4.5 was recorded and converted into mgCaCO₃/L equivalents. Micrographs were obtained with a digital microscope model VHX-5000 (Keyence Corp, Japan) with a 100-fold augmentation. Oil and fat method was performed by Silliker Netherlands B.V, (The Netherlands) according to standard NEN 6671. Kjeldahl Nitrogen (Kj-N) was performed by Eurofins Analytico B.V, (The Netherlands) based on method NEN-ISO 5663. Kj-N, TC and TOC for Harnaschpolder and Nieuwgraaf WWTPs and oil and fat from Kralingseveer were not determined due to sanitary restrictions.

5.2.3 Sludge pre-treatment

Pre-treatment of sludge was performed with a heat exchanger composed of an aluminum coil; a water bath with internal recirculation MX20H135-A11B (Polyscience, U.S.A); a peristaltic pump model 520S (Watson-Marlow, U.K); a mixer model 036090000 Series RZR 1 (Heidolph, Germany); and a borosilicate beaker of 600 mL capacity. 450 g of dewatered sludge (~8 % TS) were pumped from the beaker into the coil which was submerged in the pre-heated water bath at 71.8 °C. Finally, the warmed sludge was returned to the beaker and the cycle was repeated. The temperature of the sludge in the beaker was measured with digital thermometers in two different locations to monitor possible temperature gradients. H₂O₂ at a concentration of 30 % w/w (Merck KGaA, Germany) was dosed to reach a concentration of 15 mg H₂O₂/g TS. The addition of H₂O₂ occurred 10 min after the sludge reached a temperature of 70 °C; then such temperature was maintained for 30 min.

5.2.4 Synthetic wastewaters

Four synthetic wastewaters (Aiyuk and Verstraete, 2004; Martín et al., 2010; Ozgun et al., 2013; Xu et al., 2017), a synthetic wastewater formulated in our lab (SWW-1), and its modified version (SWW-2) were prepared with lab-grade reagents and tap water. While the first 3 recipes were not originally intended to cultivate sludge, they were claimed to be representative of domestic or municipal wastewater. The four studied recipes and the samples of wastewater from full-scale WWTP and the analysis shown in section 3.2 were used as a baseline for the formulation of the growth-media proposed in this study. Compared to SWW-1, SWW-2 consisted of a) the addition of Sigma-Aldrich humic acid; b) the decrease in concentration of fulvic and humic acids; c) the addition of collagen; d) the decrease in egg-white powder; and e) the removal of bentonite. The resulting COD concentrations were between 300-15,000 mg/L. The formulas were then diluted with tap-water to a COD ≈ 300 mg/L and the analytical analyses were performed to the diluted solutions. Finally, to account for the ~10 % variation in COD resulting from dilution error, the values from the analyses were normalized to a hypothetical solution of COD ≡ 300 mg/L. Similarly, the concentration of reagent to achieve a COD ≡ 300 mg/L was calculated and presented in Table S5-3.

5.2.5 SBR operation

A sequencing batch reactor (SBR) with a working volume of 100 L was operated continuously (Figure 5.1). The reactor was inoculated with WAS from Harnaspolder WWTP to an initial mixed liquor suspended solids (MLSS) concentration of ~ 0.5 g/L. The inoculum was exposed to the proposed growth medium during ~ 2.5 months until an MLSS concentration of ~ 4 g/L. The concentration of ammonium and phosphate in the growth medium started with $\sim 25\%$ of the dose and increased in proportion to the MLSS. The solids retention time (SRT), organic loading rate (OLR) and food-to-microorganism ratio (F/M) were 18.6 ± 2.1 d; 0.23 ± 0.02 kg O_2/m^3 d; and 0.08 ± 0.01 kg/kg d, respectively. Such values are typical of lowly-loaded systems with biological nutrient removal (Tchobanoglous et al., 2003). The temperature was kept between 20-21 °C during the operation and the hydraulic residence time was around 26 h.

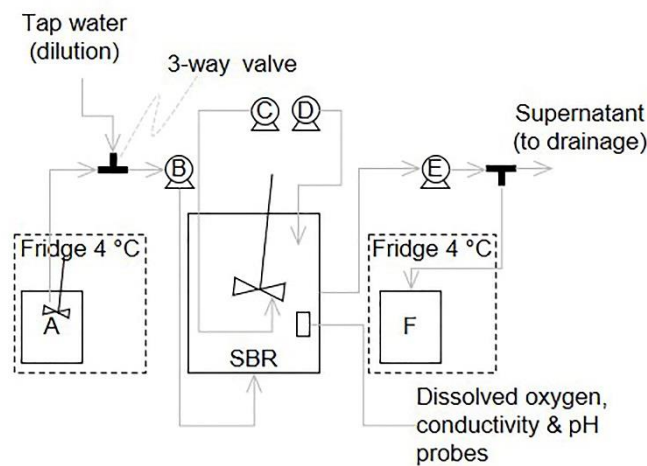

Figure 5.1 Experimental set-up. a) concentrated feed tank; b) influent pump; c) air compressor; d) methanol pump; e) effluent pump; f) excess-sludge tank.

The configuration and stage duration of the SBR is shown in Figure 5.2. Except for settling and decanting, mixing was provided during all stages with an overhead stirrer model IKA RW16 basic (IKA Werke GmbH & CO. KG, Germany). The SBR performed 3 cycles per day with a duration of 8 h each. Valves, pumps and air compressors were connected to a programmable logic controller LabView software (NI Corp., U.S.A.). pH and conductivity were measured with the probes mentioned above and retrieved with a multimeter model 3620IDS (Xylem Inc, U.S.A.). No pH adjustment was performed during operation.

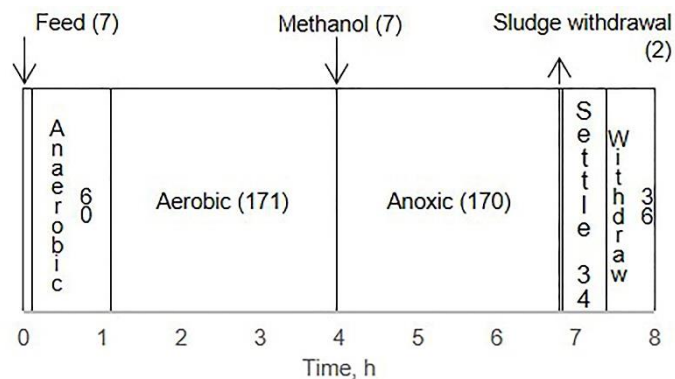

Figure 5.2 Sequence of treatment and stage duration. Numbers in parenthesis represent time in minutes.

The synthetic wastewater SWW-1 in Table S5-3 was concentrated until a COD ≈ 10 g/L in a 20 L container and stored at 4 °C for a maximum of 4 days. The variation of COD during storage was <5%, and was considered negligible. An overhead stirrer model 036090000 Series RZR 1 (Heidolph, Germany) was activated during the feeding phase to prevent settling of the concentrated synthetic wastewater during storage. At the start of the anaerobic phase, the concentrated synthetic wastewater was fed from the bottom of the SBR for 7 min and then tap water was added during 60 min to reach a COD ≈ 500 mg/L. In the aerobic stage, air was injected with an air compressor via 2 air diffusers located at the bottom of the SBR. Dissolved oxygen (DO) was measured with an optical dissolved oxygen sensor model WQ401 (Xylem Inc, U.S.A.). Air was provided whenever the DO concentration dropped below 1.3 ± 0.1 mg O₂/L. Due to a delay in the response of the sensor-software interface, the actual DO concentration of the mixed liquor remained between 1-3.5 mg O₂/L along the aerobic stage (171 min). In the anoxic stage (170 min), methanol was added as carbon source for denitrification and at the end of the phase, 1.5 L of excess sludge was withdrawn for 2 min. The liquor was then conveyed to a container and maintained at 4 °C for a maximum of 1 week until sufficient sample was available for the realization of analyses.

5.2.6 Experimental phases

The experiments with the SBR were divided into two phases with the same operational conditions but distinct composition of the used synthetic wastewater. In the first phase, SWW-1 (Table S5-3) was fed in the SBR for growing the sludge and until day 32 of steady state. From day 32 to 50 a transition stage was implemented, which consisted in the gradual modification of the feed from the proposed synthetic wastewater to SWW-2. During the second phase (day 50 until the end of the experiment), the SBR was fed with the modified synthetic wastewater.

The rationale behind the second phase was to induce a modification in the biodegradability of the lab-grown sludge by adding recalcitrant organic matter (humic acid and hydrolyzed collagen) in the modified synthetic wastewater. The composition of SWW-2 was in such way adjusted so that its characteristics remained similar to SWW-1. For instance, a portion of the technical-grade mixture of fulvic (17%) and humic (4%) acids in SWW-1 was replaced by Sigma-Aldrich humic acid in SWW-2. Similarly, about one-fourth of the egg-white in SWW-1 was replaced by hydrolyzed collagen in SWW-2 and bentonite and iron were removed from the wastewater because the analytical-grade humic acid already contained those metals.

Along the SBR operation, pH; ORP; and conductivity were monitored on-line. COD, SVI, solids, ammonium and orthophosphate were determined twice a week to assess the performance of nutrient removal. Finally, samples of the cultivated sludge corresponding to the 1st; 2nd; 4th; 4.5th; and 5th; SRT of operation were collected for the realization of TS, COD, EPS, VFA, SMP and ICP-OES analyses as described above.

The software used to generate the graphs were MS Office (Microsoft Corp., U.S.A) and Adobe Photoshop (Adobe Inc., U.S.A.). Data of this study is available at [dataset] Gonzalez (2021).

5.3 Results and discussion

5.3.1 Characteristics of domestic wastewater

It is known that domestic wastewater has unique characteristics depending on location, living habits and seasonal patterns, among others. For instance, the wastewater from Kralingseveer WWTP had a 50% higher concentration of total solids and inert suspended solids compared to the other plants (Table S5-4). Similarly, a 3-fold higher concentration of phosphates, Al, Fe, Mg and a 2-fold higher concentration of Ca were detected. Such differences illustrate the unique and variant composition of wastewater, even for locations <15 km apart. However, there were also similarities in composition; the organic fraction of all 3 wastewater samples consisted largely of proteins, humic substances, carbohydrates, and lipids. Reports from Norwegian, Chinese and American domestic wastewater samples coincide, although data about the concentration of humic substances and metals is rather scarce (Huang et al., 2010; Tchobanoglous et al., 2003). Despite its uniqueness per location, domestic wastewater is expected to be composed of a mixture of compounds that is related to basic human activities such as sanitation and food preparation.

5.3.2 Comparison between domestic and synthetic wastewater

Residuals generated by basic human activities comprise fibers, urea, humic-like substances and metals. However, the recipes of synthetic wastewaters lack or have considerably lower concentrations of humic substances and metals (Table S5-4), which likely has a strong influence on the characteristics of lab-grown sludge (Aiyuk and Verstraete, 2004; Layer et al., 2019; Xu et al., 2017). In the framework of our present research, we propose to provide a recipe of a new synthetic wastewater that includes constituents which may result into the cultivation of a slowly-biodegradable sludge as discussed below.

5.3.2.1 Substrate biodegradation

The lower oxygen consumption rate in the carbonaceous BOD (CBOD₅) assays of the growth media from Martín et al. (2010); Aiyuk and Verstraete (2004) and SWW-1, suggests a slower biodegradation of the substrate compared to the other two synthetic wastewaters (Figure 5.3). Moreover, the former recipes had a CBOD₅/COD ratio more similar to the sampled domestic wastewater (0.37-0.52 vs 0.4-0.6, respectively).

Table S5-3 shows that starch is the dominant carbon source in the studied synthetic wastewaters. However, starch in domestic wastewater is rapidly hydrolyzed and fermented to VFAs in the sewers, particularly at elevated temperatures, before arriving to the WWTP (Henze et al., 1997). Instead, fibers such as cellulose, hemicellulose, and lignin accounted for ~20% of TOC in a Chinese domestic wastewater Huang et al., (2010). Such polymeric substrates are more refractory to biodegradation (B.

Wang et al., 2018), which delays their utilization. In addition, in order to hydrolyze these more complex polymeric substrates, different kinds of (exo-)enzymes are expected to be produced by the microorganisms, which may result in a higher production of extracellular polymeric substances (EPS) in activated sludge compared to systems which are fed with more easily degradable substrates (Cadoret et al., 2002; Li and Yang, 2007; B. Wang et al., 2018). The concentration and composition of EPS is particularly relevant to the biodegradation of WAS because of its high concentration in the sludge, its low biodegradation, and its role in agglomerating the cellular biomass (Guo et al., 2020; Li and Yang, 2007).

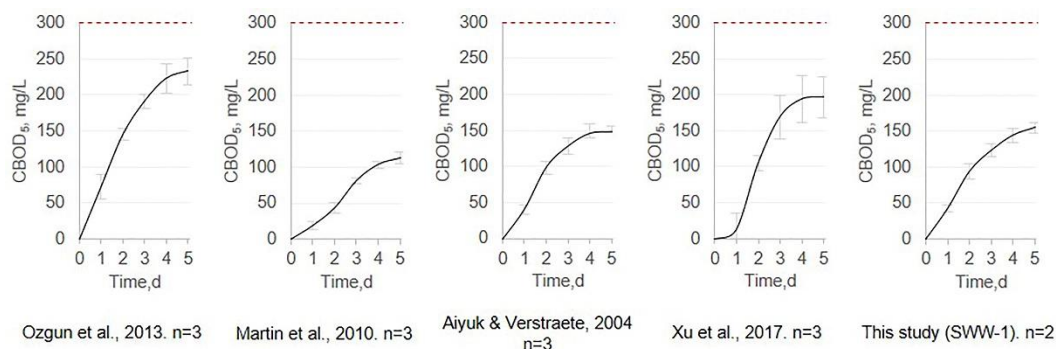

Figure 5.3 CBOD₅ of synthetic wastewater samples. Dashed line is the maximum theoretical value.

5.3.2.2 Complexation reactions

5.3.2.2.1 Aromatic compounds

Lignocellulosic matter is present in domestic wastewater in the form of residues of food waste and toilet paper in large parts of the world. The bond that lignin forms between labile organics, results into slowly-biodegradable moieties: while cellulose and hemicellulose are biodegradable, their encrustation with lignin results into recalcitrant lignocellulosic compounds (Hu et al., 2016). Similarly, the formation of hydrogen bonds between the carboxyl group of proteins and the hydroxyl groups of tannins and lignin also results into recalcitrant molecules (Zahedifar et al., 2002).

As already mentioned, the synthetic wastewaters studied in this manuscript were deficient in humic substances (Figure S5-1). Humic and humic-like substances in domestic wastewater originate from the reaction between carbohydrates and proteins during food processing and from industrial operations such as leather and wood processing (Kliaugaite et al., 2013; Peschel and Wildt, 1988) and from vegetable waste. Humic-substances are not only recalcitrant –accounting for 3%-28% of the dissolved organic matter in effluents of WWTP (Kliaugaite et al., 2013; Lipczynska-kochany, 2018), but they are also reactive as chelating agents, electron donors and acceptors and as enzyme immobilization agents, among others (Li and Yang, 2007; B. Wang et al., 2018). Actually, EPS in sludge comprises of a substantial concentration of humic substances and their absence in the growth medium has been related to a deficient formation of a humic fraction in lab-grown sludge (Labelle et al., 2011; Xu et al., 2017).

5.3.2.2.2 Metals

The concentration of metal-ions adsorbing onto the sludge matrix depends on the influent concentration and the metal dosage in the WWTP, e.g., phosphate removal or flocculation (lime, iron or

aluminum). Drinking water can have different concentrations of calcium and magnesium (hardness). The type of sewerage system, i.e., combined or separated, will largely determine the concentration of trace metals such as copper, lead, iron, zinc, and manganese. In addition, domestic and industrial activities contribute to the metal loading that ultimately arrives to the sewers.

The bivalent cation bridging (BCD) model explains the electrostatic attraction between the negatively charged functional groups in the EPS of sludge and multivalent cations (Higgins and Novak, 1997a; E Neyens and Baeyens, 2003). Li et al. (2012) observed that certain cations were selectively located in specific fractions of the EPS of sludge. As the pellet fraction of WAS is assumed to be especially recalcitrant, the presence of specific bridging cations in the pellet could be pivotal for the formation of a slowly-biodegradable sludge. Examination of sludge from Kralingseveer WWTP showed that >99% of Al and Fe in sludge was located in the pellet fraction (absolute concentrations are shown in Figure S5-2). In contrast, only 81% and 59% of the total pool of Ca and Mg were detected in the pellet, suggesting a possible substantial role of Al and Fe in the assembly of this fraction. (In some WWTPs, both Al and Fe are added as coagulants to bind organics.) The estimation of the charge equivalents also suggests a substantial contribution of Al and Fe in the assembly of the recalcitrant pellet fraction of WAS (Table 5.1).

Table 5.1 Charge equivalents in the pellet fraction of WAS.

Element	Assumed valence	μEquiv/gTS
Ca	2	1695
Mg	2	1067
Fe	2	1623
Al	3	1329

The role of cations in the activated sludge process is not constrained to a mere bridging effect: Both K and Mg are required as counter ions for biological phosphorus removal (Bracklow et al., 2007; Rickard and McClintock, 1992). Moreover, metal-organic complexes possess a higher bond energy compared to the non-complexed components (Guo et al., 2016; Xu et al., 2020). For instance, the non-covalent bond (electrostatic interaction and hydrogen bonding) between bovine serum albumin (BSA) and silica (SiO₂) resulted into a high structural stability of BSA and ultimately diminished the production of biogas during anaerobic digestion (Dai et al., 2017b).

5.3.2.3 Trace elements

Some trace elements are essential to mediate biochemical reactions but their excessive concentration may result into inhibition of biological processes (Hendriks et al., 2018; Lipczynska-kochany and Kochany, 2009; Xu et al., 2020). Whether the sewer system is combined or separated might have a prominent effect in the concentration of trace elements. Most of the studied synthetic wastewaters had a deficiency of trace elements compared to the samples of wastewater in this study, the latter being originated from combined sewer systems (Figure S5-3). On the other hand, the formulas of Martín et al., (2010) and Ozgun et al., (2013), had a considerably higher concentration of cobalt compared to domestic wastewater. Based on the concentrations and composition of trace elements in wastewater and on the growth requirement for anaerobic organisms (Hendriks et al., 2018), a new trace element solution was formulated (Table S5-5) and included in the proposed synthetic wastewater.

5.3.3 Impact of growth media on methane production of pre-treated lab-grown sludge

5.3.3.1 Steady-state and macroscopic characteristics of lab-grown sludge

The SBR was inoculated with fresh aerobic sludge from a CAS system and exposed to the proposed growth medium until ~4000 mg MLSS/L was reached, which took ~2.5 months (time 0 in Figure 5.4). The SBR was operated for one solids retention time (SRT = 21 days) to renew the biomass of the reactor before the start of the biodegradation (SMP) assays. Such start-up strategy ensures that the cultivated sludge responds to the characteristics of the growth medium. The ‘feed transition’ time in Figure 5.4 (from days 32 to 50), represents the progressive shift from SWW-1 to SWW-2 in Table S5-3, which was fed until the end of operation.

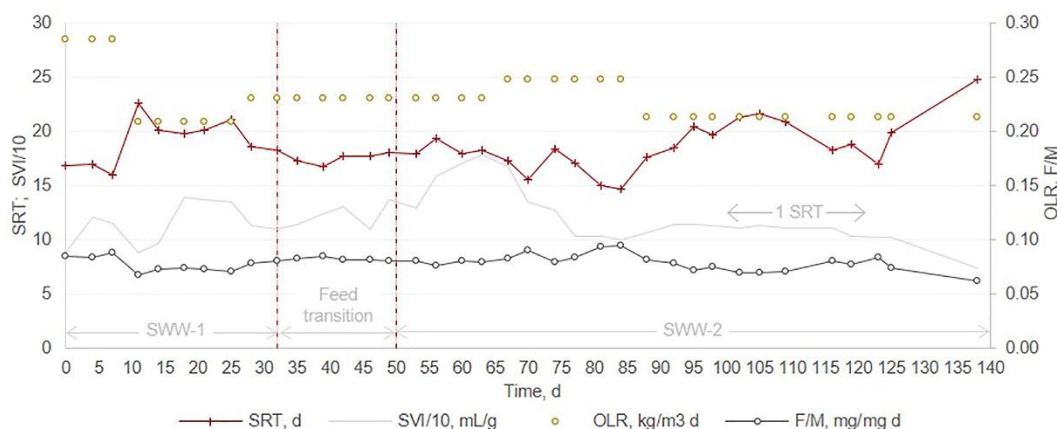

Figure 5.4 Operational parameters and phases during the experiment.

The SVI mostly remained above 100 mL/g, although it increased temporally until 175 mL/g apparently as a response to the modified medium (Figure 5.4). Such high SVI could be explained by the polymeric nature of the growth medium used (Adler and Holliger, 2020; Martins et al., 2011). A precipitate composed of black solids (similar in appearance to the humic acid used in SWW-2) was evident around day 70 (Figure S5-4).

5.3.3.2 Extracellular polymeric substances (EPS) and volatile fatty acids (VFA)

It was impossible to assess any possible change caused by the growth medium in the EPS of sludge, as EPS measurement was only performed during the second phase of the experiment (at 4th and 4.5th SRT). Both the sludge grown with SWW-2 and WAS had a similar spatial configuration of EPS for both non-treated and pre-treated samples (Figure S5-5). Moreover, similar concentrations and speciation of VFAs were detected during the entire experimental period, with no obvious effects caused by the modified medium (Figure S5-6).

Overall, the results on EPS and VFA suggest that the lab-grown sludge had a similar composition and structure compared to WAS. The presence of a humic fraction in all the EPS layers of the lab-grown sludge is considered relevant (Figure S5-5b), as such fraction was absent in a previous experiment (Labelle et al., 2011). Also, there was a similar concentration and speciation of VFAs during the SMP tests of the pre-treated lab-grown sample compared to WAS (Figure S5-6a' and b').

5.3.3.3 Trace elements and metals

While the concentration of trace elements was similar to WAS (Figure S5-7), Ca and Na were almost doubled in the lab-grown sludge (Figure S5-8). Since several reagents in the synthetic wastewater were sodium-based, calcium chloride was included to circumvent the pervasive effect of Na in the bridging of sludge (Higgins and Novak, 1997b). However, the addition of humic acid sodium-salt in the modified medium ultimately resulted into a progressive increase in sodium and a decrease in calcium in the cultivated sludge (Figure 5.5). As a consequence, the monovalent-to-divalent cations ratio (M/D) –which is based on the charge equivalents of Na; K; Ca; and Mg of the cultivated sludge, increased (Figure 5.5).

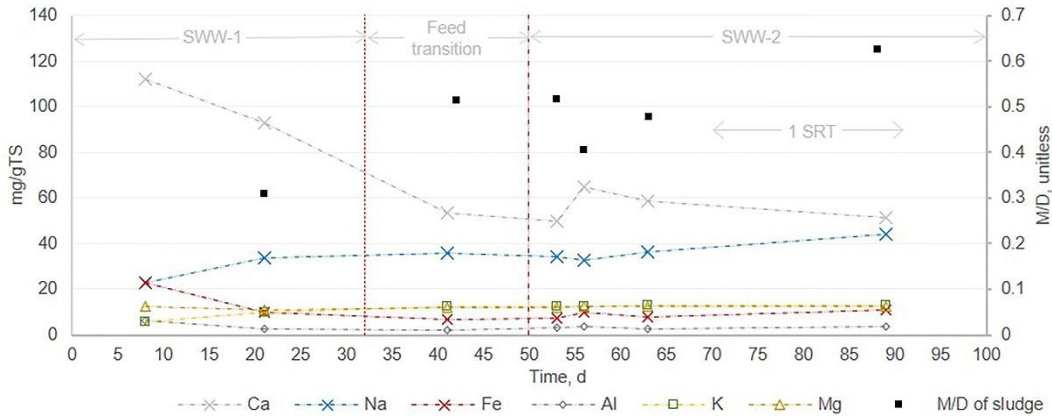

Figure 5.5 Concentration of some metals and M/D ratio of the lab-grown sludge during operation.

5.3.3.4 Methane production rate (k_{CH_4})

Substantial discrepancies were observed on the methane production rate. Figure 5.6a and b show that the rate of methane production from the rapidly-biodegradable fraction of sludge ($k_{CH_4-Rapid}$), remained similar or even decreased after the exposure to pre-treatment. This result is in clear conflict with the observations from WAS, as increments are commonly reported (Figure S5-9)(Gonzalez et al., 2020; Pilli et al., 2014).

The findings about methane production rate of the slowly-biodegradable fraction of lab-grown sludge (k_{CH_4-Slow}) can be divided in two parts. Firstly, the k_{CH_4-Slow} of the non-treated sludge tended to increase at the end of the operation, which coincides with the application of the modified medium (Figure 5.6c). This suggests that the sludge cultivated with SWW-2 was more labile and easier to hydrolyze than the sludge grown with SWW-1. Secondly, the application of pre-treatment increased the k_{CH_4-Slow} of sludge except for the last sample, in which even a notorious decrease was detected (Figure 5.6d).

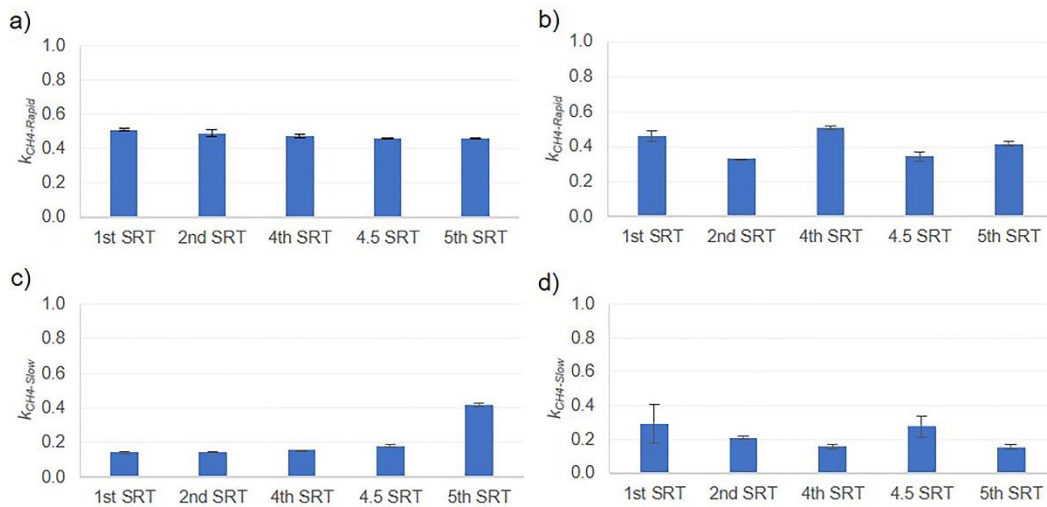

Figure 5.6 Methane production rates, a) non-treated, rapid; b) pre-treated, rapid; c) non-treated, slow; and d) pre-treated, slow. Units in d⁻¹.

As the application of low-temperature pre-treatment in WAS often derives into increments of methane production rate of both the rapidly and slowly biodegradable fractions (Figure S5-9)(Gonzalez et al., 2020; Pilli et al., 2014), it is clear that the lab-grown sludge had a substantially distinct response to pre-treatment compared to the WAS. This deviation poses a limitation on the utilization of the cultivated lab-grown sludge for studies on the kinetics of biogas production. In addition, it was clear that neither the modification of the spatial distribution of EPS or the concentration of VFA were satisfactory indicators for methane production rate.

5.3.3.5 Specific methane production (SMP)

Lastly, the specific methane production (SMP) of lab-grown sludge was clearly influenced by the characteristics of the medium (Figure 5.7). The sludge cultivated with SWW-1 (1st and 2nd SRT) demonstrated an increased specific methane production as a result of pre-treatment. This response was similar to the response obtained in WAS under similar pre-treatment conditions (Gonzalez et al., 2020; Pilli et al., 2014). On the other hand, the sludge grown using SWW-2 resulted into a null response to pre-treatment. Figure 5.7 shows that while the SMP of the pre-treated samples from 4th to 5th SRT remain similar, the non-treated sludge became more biodegradable. Ultimately, the SMP of both the non-treated and pre-treated samples became similar and pre-treatment apparently became ineffective.

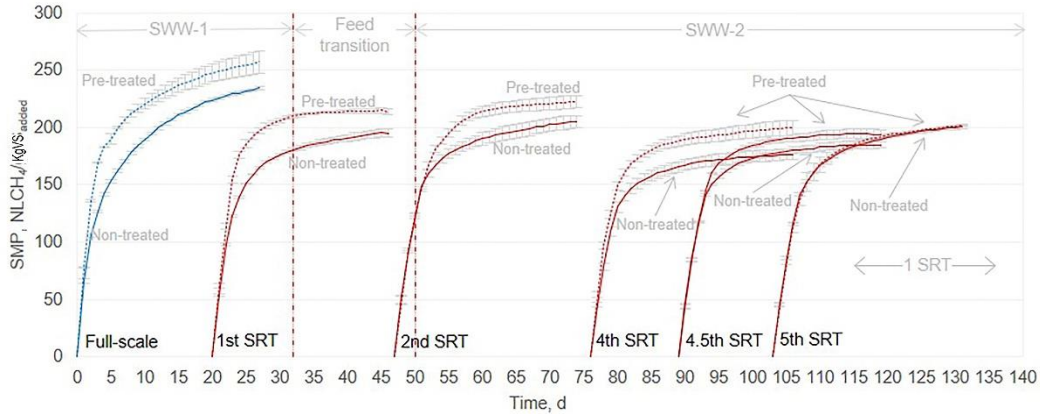

Figure 5.7 SMP of full-scale and lab-grown sludge.

5.3.4 Overall discussion

5.3.4.1 Requirements for synthetic municipal wastewater

The incorporation of polymeric substrates such as cellulose and albumin in the synthetic wastewater was expected to result into a higher concentration of EPS in the cultivated sludge. Likewise, complex aromatic compounds such as lignin and humic substances together with a variety of metals might have resulted in increasing chemical bridging and complexation reactions. The addition of more complex organic compounds together with a sufficient level of trace metals and a diverse and active inoculum, were expected to result in slowly-biodegradable sludge.

5.3.4.2 Effect of growth-media on methane production of (pre-treated) lab-grown sludge

The evidence presented in this study suggests that not only the biodegradation of lab-grown sludge varied according to the characteristics of the growth media, but also that the effect of pre-treatment depended on the inherent biodegradation of the slowly-biodegradable fraction of the sludge (Figure 5.7). As several components from the growth medium were modified during the second phase of the experiment, it is impossible to allocate the observed effects on SMP to a specific constituent of the synthetic wastewater. However, two possible mechanisms might explain why the pre-treatment was unable to increase the SMP of the lab-grown sludge during the end of the operation:

5.3.4.2.1 Increase in M/D ratio

During feeding of SWW-2, the concentration of sodium embedded in the sludge increased, while the concentration of calcium decreased. Overall, such modifications resulted into a progressive increase in the M/D ratio (Figure 5.5). A previous report found the M/D ratio to be relevant for flocculation and settling properties (Higgins and Novak, 1997c). The observation was mechanistically explained by an ionic-exchange mechanism in which sodium displaced calcium in the sludge matrix, which affected the concentration of bound protein in sludge (Higgins and Novak, 1997a). This was supported by the observation that an increased sodium concentration was related to a decrease in the bound protein concentration. On the other hand, the increase in Ca and Mg in the feed was associated with an increase in the bound exocellular protein concentration (Higgins and Novak, 1997a). In the present study, a decrease in bound protein might explain the loss of performance of pre-treatment, although this is

speculative since EPS measurements were carried out only during the second phase of the experiment (addition SWW-2).

5.3.4.2.2 Possible enzyme-humic substances complexation

Another possible mechanism is the modification of the ratio of fulvic and humic acids. The SWW-1 included a mixture of 17% fulvic and 4% of humic acid, while SWW-2 contained a substantial concentration of humic acid sodium-salt (Table S5-3). We speculate that the biological availability of metals was decreased by the higher concentration of humic acid that may have acted as a chelating agent (Lipczynska-kochany and Kochany, 2008). The loss in performance in P-removal observed during the second phase (Appendix 5-1 and Figure 5.8), could be provoked by a lower availability of K and Mg (Rickard and McClintock, 1992). In addition, a higher chelation could have diminished the bridging effects in sludge, resulting into a weaker assembly that possibly induced the higher biodegradation of the cultivated sludge. Such effect has been observed after the addition of the chelator EDTA to WAS, in which the sequestering of iron played a key role in the increase of biodegradability of WAS (Xu et al., 2017). Thus, the blackish solids observed during the second experimental phase might be the result of precipitated humic acid-iron complexes (Figure S5-4)(Boguta et al., 2019).

Since the above possible mechanisms involve metals, it is probable that metals are a pivotal factor predicting not only the biodegradation of sludge (Xu et al., 2017), but also in the effectiveness of the pre-treatment at the conditions implemented in this study.

5.4 Conclusion

The evidence presented in this study suggests not only that the biodegradation extent of lab-grown sludge was determined by the composition of growth medium, but also the extent of the effectiveness of the applied pre-treatment. The lab-grown sludge had a spatial configuration of EPS, pattern of acidification and specific methane production that was comparable to WAS before and after pre-treatment. However, substantial differences were observed for the rate of methane production, indicating a dissimilar kinetic response compared to WAS. The cultivation of a 'constant-quality' and a slowly-biodegradable sludge that responds to pre-treatment is regarded as a prerequisite for systematic comparison of pre-treatment methods and their impact.

Appendix 5-1: Biological nutrient removal.

A secondary release of phosphorus during the anoxic stage was observed from around day 50, which coincided with the use of SWW-2 (Figure 5.8). Nonetheless, during the entire experimental period, the oxidation-reduction potential and pH during the different phases followed the expected trends for biological nutrient removal in activated sludge (Figure 5.9). The alkalinity requirements during nitrification were met (ammonium in the effluent was usually <0.05 mg/L), and still the growth medium provided sufficient residual alkalinity (Table S5-6).

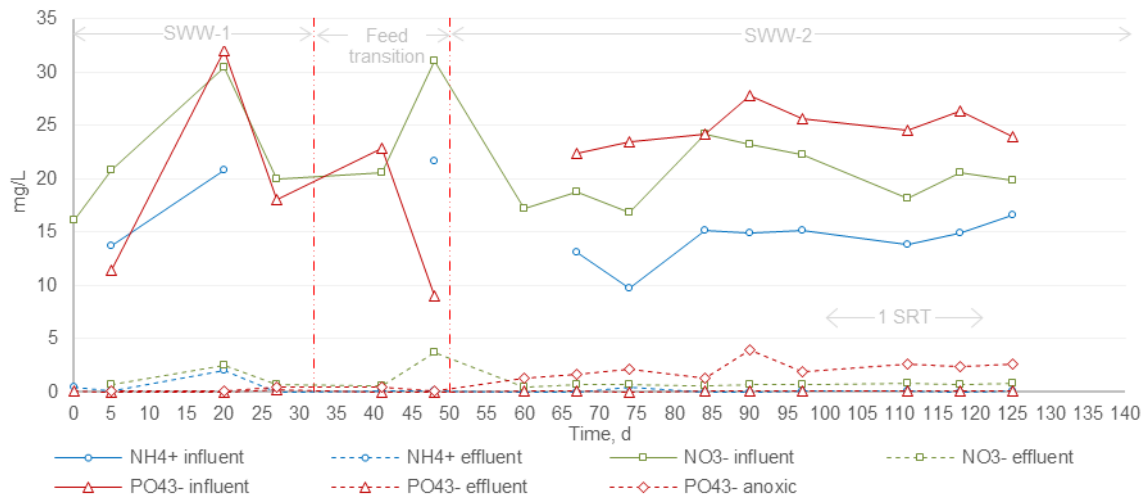

Figure 5.8 Performance of biological nutrient removal.

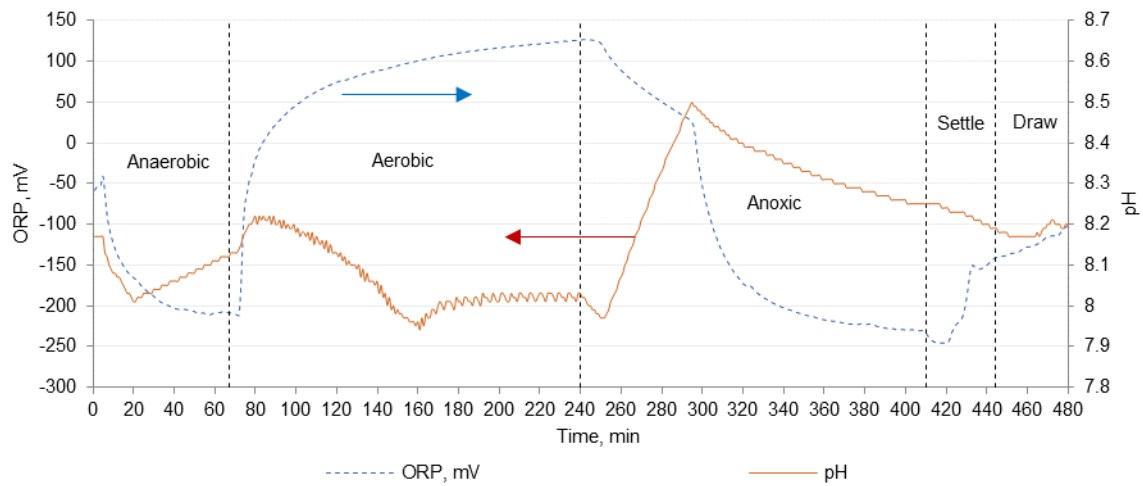

Figure 5.9 ORP and pH curves during a SBR cycle.

5.5 References

- Adler, A., Holliger, C., 2020. Multistability and reversibility of aerobic granular sludge microbial communities upon changes from simple to complex synthetic wastewater and back. *Front. Microbiol.* 11, 1–20. <https://doi.org/10.3389/fmicb.2020.574361>
- Aiyuk, S., Verstraete, W., 2004. Sedimentological evolution in an UASB treating SYNTHES, a new representative synthetic sewage, at low loading rates. *Bioresour. Technol.* 93, 269–278. <https://doi.org/10.1016/j.biortech.2003.11.006>
- APHA, AWWA, WEF, 2017. *Standard Methods for the Examination of Water and Wastewater*, 23rd ed. American Public Health Association, Washington.
- Boguta, P., D’Orazio, V., Senesi, N., Sokołowska, Z., Szewczuk-Karpisz, K., 2019. Insight into the interaction mechanism of iron ions with soil humic acids. The effect of the pH and chemical properties of humic acids. *J. Environ. Manage.* 245, 367–374. <https://doi.org/10.1016/j.jenvman.2019.05.098>
- Bracklow, U., Drews, A., Vocks, M., Kraume, M., 2007. Comparison of nutrients degradation in small scale membrane bioreactors fed with synthetic/domestic wastewater. *J. Hazard. Mater.* 144, 620–626. <https://doi.org/10.1016/j.jhazmat.2007.01.085>
- Cadore, A., Conrad, A., Block, J., 2002. Availability of low and high molecular weight substrates to extracellular enzymes in whole and dispersed activated sludge. *Enzyme Microb. Technol.* 31, 179–186. [https://doi.org/https://doi.org/10.1016/S0141-0229\(02\)00097-2](https://doi.org/https://doi.org/10.1016/S0141-0229(02)00097-2)
- Dai, X., Xu, Y., Dong, B., 2017a. Effect of the micron-sized silica particles (MSSP) on biogas conversion of sewage sludge. *Water Res.* 115, 220–228. <https://doi.org/10.1016/j.watres.2017.02.064>
- Dai, X., Xu, Y., Lu, Y., Dong, B., 2017b. Recognition of the key chemical constituents of sewage sludge for biogas production. *RSC Adv.* 7, 2033–2037. <https://doi.org/10.1039/c6ra26180a>
- Gonzalez, A., Guo, H., Ortega-Ibáñez, O., Petri, C., van Lier, J.B., de Kreuk, M., Hendriks, A., 2020. Mild thermal pre-treatment of waste activated sludge to increase loading capacity, biogas production, and solids’ degradation: A pilot-scale study. *Energies* 13, 6059. <https://doi.org/10.3390/en13226059>
- [dataset] Gonzalez, A., 2021. SBR monitoring. Mendeley Data, v1, <http://dx.doi.org/10.17632/3h4rdsz5gx.1>
- Guo, H., Felz, S., Lin, Y., van Lier, J.B., de Kreuk, M., 2020. Structural extracellular polymeric substances determine the difference in digestibility between waste activated sludge and aerobic granules. *Water Res.* 181, 115924. <https://doi.org/10.1016/j.watres.2020.115924>
- Guo, X., Wang, X., Liu, J., 2016. Composition analysis of fractions of extracellular polymeric substances from an activated sludge culture and identification of dominant forces affecting microbial aggregation. *Sci. Rep.* 6. <https://doi.org/10.1038/srep28391>
- Hendriks, A.T.W.M., Lier, J.B. Van, Kreuk, M.K. De, 2018. Growth media in anaerobic fermentative processes: The underestimated potential of thermophilic fermentation and anaerobic digestion. *Biotechnol. Adv.* 36, 1–13. <https://doi.org/10.1016/j.biotechadv.2017.08.004>
- Henze, M., Aspegren, H., Jansen, J.C., Nielsen, P.H., Lee, N., 1997. Effect of solids retention time and wastewater characteristics on biological phosphorus removal. *Water Sci. Technol.* 45, 137–144. <https://doi.org/https://doi.org/10.2166/wst.2002.0101>
- Higgins, M.J., Novak, J.T., 1997a. Characterization of exocellular protein and its role in bioflocculation. *J. Environ. Eng.* 123, 479–485. [https://doi.org/https://doi.org/10.1061/\(ASCE\)0733-9372\(1997\)123:5\(479\)](https://doi.org/https://doi.org/10.1061/(ASCE)0733-9372(1997)123:5(479))
- Higgins, M.J., Novak, J.T., 1997b. Dewatering and settling of sludges: the case for using cation analysis. *Water Environ. Res.* 69, 225–232. <https://doi.org/https://doi.org/10.2175/106143097X125380>
- Higgins, M.J., Novak, J.T., 1997c. The effect of cations on the settling and dewatering of activated

- sludges: Laboratory results. *Water Environ. Res.* 69, 215–224. <https://doi.org/10.2307/25044865>
- Hu, Y., Hao, X., Wang, J., Cao, Y., 2016. Enhancing anaerobic digestion of lignocellulosic materials in excess sludge by bioaugmentation and pre-treatment. *Waste Manag.* 49, 55–63. <https://doi.org/10.1016/j.wasman.2015.12.006>
- Huang, M., Li, Y., Gu, G., 2010. Chemical composition of organic matters in domestic wastewater. *Desalination* 262, 36–42. <https://doi.org/10.1016/j.desal.2010.05.037>
- Kliaugaite, D., Yasadi, K., Euverink, G., Bijmans, M.F.M., Racys, V., 2013. Electrochemical removal and recovery of humic-like substances from wastewater. *Sep. Purif. Technol.* 108, 37–44. <https://doi.org/10.1016/j.seppur.2013.01.055>
- Labelle, M., Ramdani, A., Deleris, S., Gadbois, A., Dold, P., Comeau, Y., 2011. Ozonation of endogenous residue and active biomass from a synthetic activated sludge. *Water Sci. Technol.* 63, 297–302. <https://doi.org/10.2166/wst.2011.053>
- Layer, M., Adler, A., Reynaert, E., Hernandez, A., Pagni, M., Morgenroth, E., 2019. Organic substrate diffusibility governs microbial community composition, nutrient removal performance and kinetics of granulation of aerobic granular sludge. *Water Res.* X 4, 100033. <https://doi.org/10.1016/j.wroa.2019.100033>
- Li, H., Wen, Y., Cao, A., Huang, J., Zhou, Q., Somasundaran, P., 2012. The influence of additives (Ca²⁺, Al³⁺, and Fe³⁺) on the interaction energy and loosely bound extracellular polymeric substances (EPS) of activated sludge and their flocculation mechanisms. *Bioresour. Technol.* 114, 188–194. <https://doi.org/10.1016/j.biortech.2012.03.043>
- Li, X., Yang, S.F., 2007. Influence of loosely bound extracellular polymeric substances (EPS) on the flocculation, sedimentation and dewaterability of activated sludge. *Water Res.* 41, 1022–1030. <https://doi.org/10.1016/j.watres.2006.06.037>
- Lipczynska-kochany, E., 2018. Humic substances, their microbial interactions and effects on biological transformations of organic pollutants in water and soil: A review. *Chemosphere* 202, 420–437. <https://doi.org/10.1016/j.chemosphere.2018.03.104>
- Lipczynska-kochany, E., Kochany, J., 2009. Effect of humate on biological treatment of wastewater containing heavy metals. *Chemosphere* 77, 279–284. <https://doi.org/10.1016/j.chemosphere.2009.07.036>
- Lipczynska-kochany, E., Kochany, J., 2008. Application of aerobic respirometry: studies on the impact of humate on biological treatment of municipal sewage. *Environ. Technol. (United Kingdom)* 29, 641–649. <https://doi.org/10.1080/09593330801984860>
- Liu, J., Yang, Q., Wang, D., Li, Xiaoming, Zhong, Y., Li, Xin, Deng, Y., Wang, L., Yi, K., Zeng, G., 2016. Enhanced dewaterability of waste activated sludge by Fe(II)-activated peroxydisulfate oxidation. *Bioresour. Technol.* 206, 134–140. <https://doi.org/10.1016/j.biortech.2016.01.088>
- Martín, M.A., De la Rubia, M.A., Martín, A., Borja, R., Montalvo, S., Sánchez, E., 2010. Kinetic evaluation of the psychrophilic anaerobic digestion of synthetic domestic sewage using an upflow filter. *Bioresour. Technol.* 101, 131–137. <https://doi.org/10.1016/j.biortech.2009.08.010>
- Martins, A.M.P., Karahan, O., van Loosdrecht, M.C.M., 2011. Effect of polymeric substrate on sludge settleability. *Water Res.* 45, 263–273. <https://doi.org/10.1016/j.watres.2010.07.055>
- Neumann, P., Pesante, S., Venegas, M., Vidal, G., 2016. Developments in pre-treatment methods to improve anaerobic digestion of sewage sludge. *Rev. Environ. Sci. Biotechnol.* 15, 173–211. <https://doi.org/10.1007/s11157-016-9396-8>
- Neyens, E., Baeyens, J., 2003. A review of thermal sludge pre-treatment processes to improve dewaterability. *J. Hazard. Mater.* 98, 51–67. [https://doi.org/10.1016/S0304-3894\(02\)00320-5](https://doi.org/10.1016/S0304-3894(02)00320-5)
- Ozgun, H., Ersahin, M.E., Tao, Y., Spanjers, H., van Lier, J.B., 2013. Effect of upflow velocity on the effluent membrane fouling potential in membrane coupled upflow anaerobic sludge blanket reactors. *Bioresour. Technol.* 147, 285–292. <https://doi.org/10.1016/j.biortech.2013.08.039>

- Peschel, G., Wildt, T., 1988. Humic substances of natural and anthropogeneous origin. *Water Res.* 22, 105–108. [https://doi.org/https://doi.org/10.1016/0043-1354\(88\)90136-4](https://doi.org/https://doi.org/10.1016/0043-1354(88)90136-4)
- Pilli, S., Yan, S., Tyagi, R.D., Surampalli, R.Y., 2014. Thermal pretreatment of sewage sludge to enhance anaerobic digestion: A review. *Crit. Rev. Environ. Sci. Technol.* 45, 669–702. <https://doi.org/10.1080/10643389.2013.876527>
- Ranjbar, L., Yamini, Y., Saleh, A., Seidi, S., Faraji, M., 2012. Ionic liquid based dispersive liquid-liquid microextraction combined with ICP-OES for the determination of trace quantities of cobalt, copper, manganese, nickel and zinc in environmental water samples. *Microchim. Acta* 177, 119–127. <https://doi.org/10.1007/s00604-011-0757-2>
- Rickard, L.F., McClintock, S.A., 1992. Potassium and Magnesium requirements for enhanced biological Phosphorus removal from wastewater. *Water Sci. Technol.* 26, 2203–2206. <https://doi.org/https://doi.org/10.2166/wst.1992.0697>
- Ruffino, B., Cerutti, A., Campo, G., Scibilia, G., Lorenzi, E., Zanetti, M., 2019. Improvement of energy recovery from the digestion of waste activated sludge (WAS) through intermediate treatments: The effect of the hydraulic retention time (HRT) of the first-stage digestion. *Appl. Energy* 240, 191–204. <https://doi.org/10.1016/j.apenergy.2019.02.061>
- Shoaei, H., Roshdi, M., Khanlarzadeh, N., Beiraghi, A., 2012. Simultaneous preconcentration of copper and mercury in water samples by cloud point extraction and their determination by inductively coupled plasma atomic emission spectrometry. *Spectrochim. Acta - Part A Mol. Biomol. Spectrosc.* 98, 70–75. <https://doi.org/10.1016/j.saa.2012.08.027>
- Tchobanoglous, G., Burton, F.L., Stensel, H.D., Metcalf & Eddy (Eds.), 2003. *Wastewater engineering: Treatment and reuse*, 4th ed. ed, McGraw-Hill series in civil and environmental engineering. McGraw-Hill, Boston.
- Wang, B., Liu, X., Chen, J., Peng, D., He, F., 2018. Composition and functional group characterization of extracellular polymeric substances (EPS) in activated sludge: the impacts of polymerization degree of proteinaceous substrates. *Water Res.* 129, 133–142. <https://doi.org/10.1016/j.watres.2017.11.008>
- Xu, Y., Lu, Y., Dai, X., Dong, B., 2017. The influence of organic-binding metals on the biogas conversion of sewage sludge. *Water Res.* 126, 329–341. <https://doi.org/10.1016/j.watres.2017.09.046>
- Xu, Y., Lu, Y., Zheng, L., Wang, Z., Dai, X., 2020. Perspective on enhancing the anaerobic digestion of waste activated sludge. *J. Hazard. Mater.* 389, 121847. <https://doi.org/10.1016/j.jhazmat.2019.121847>
- Zahedifar, M., Castro, F.B., Ørskov, E.R., 2002. Effect of hydrolytic lignin on formation of protein-lignin complexes and protein degradation by rumen microbes. *Anim. Feed Sci. Technol.* 95, 83–92. [https://doi.org/10.1016/S0377-8401\(01\)00305-4](https://doi.org/10.1016/S0377-8401(01)00305-4)
- Zhen, G., Wang, J., Lu, X., Su, L., Zhu, X., Zhou, T., Zhao, Y., 2019. Effective gel-like floc matrix destruction and water seepage for enhancing waste activated sludge dewaterability under hybrid microwave-initiated Fe(II)-persulfate oxidation process. *Chemosphere* 221, 141–153. <https://doi.org/10.1016/j.chemosphere.2019.01.037>

Chapter 6. Overall discussion, conclusions and outlook

In this chapter, the scientific and technical implications of the relevant findings of this study are framed together.

6.1 Effects of several pre-treatments on WAS and their possible mechanisms.

While countless reports addressing the effects of pre-treatments are available, the general mechanistic understanding is very limited for most of them. There are only few studies available trying to explain the effects of pre-treatments. Therefore, at present, it is not possible to define scientifically based settings for the operational conditions to optimize each pre-treatment method, e.g., required amount of energy or doses of chemicals, which hinders an objective and fair comparison.

In addition, there is a lack of energy assessments considering not only the *quantity* but also the *quality* of energy used. In this regard, pre-treatment techniques that operate with heat instead of electricity, gas or chemical reagents can work with exchanged heat from energy conversion processes, such as coming from combined heating power. From this point of view, the application of 70 °C-pre-treatment combined with the addition of H₂O₂ is energy-wise (Chapters 2 and 3). In the case of chemical pre-treatment techniques, the consumed energy and environmental impacts behind the whole production of the reagents, including mining, industrial operation and transportation, is not commonly accounted for in energy assessments.

Since some pre-treatments make use of different treatment principles and affect different parts of the WAS structure (Chapters 2 and 4), the combination of two or even more techniques is often considered as an approach to increase their effectiveness. Nonetheless, the benefits of such approach remain controversial since it is difficult to achieve and sometimes even detect a synergistic effect. Instead, the combination of pre-treatment techniques commonly results in excessive resource use due to the overlapping of effects on WAS (Chapter 4). Apparently, profound research on the combination of two or more techniques with a moderate effect, such as described in Chapters 3 and 4, seems to be the exception rather than the rule.

From a practitioner point-of-view, it seems that the implementation of pre-treatment techniques follows two main drivers: legislative constraints related to disposal and the attempt to make WAS disposal economically more appealing, i.e., market needs. For instance, in the United Kingdom, the legislation on WAS disposal promotes the application of high-temperature thermal pre-treatment (>150 °C), since digestate is used as soil amender for agriculture with the condition of being sterilized to produce bioclass A solids. Moreover, the applied temperature improves dewaterability and decreases the dose of conditioning agent in dewatering, having a positive impact on the economics of sludge handling. In addition, most of the 'positive' effects of pre-treatments have a limited financial benefit under current regulatory or market conditions. For instance, a higher biogas production resulting from various pre-treatment techniques is often insufficient due to the required investments to adopt the pre-treatment, as well as to the fluctuating prices of gas, hampering a solid business case. In this regard, a lower consumption of conditioning agents for dewatering operations resulting from the applied pre-treatment technique, might have a higher impact on the economics of sludge management than an increased methane production.

Nonetheless, an increased methane production rate (k_{CH_4}), which is reported for most of the pre-treatment techniques studied in Chapter 2, certainly is a potential market condition of interest, stimulating the application of pre-treatments. In principle, an increased k_{CH_4} , can decrease the size of anaerobic digesters, or conversely, allow for higher organic loading rates of existing digesters (Chapter 3). This might be a possibility for current wastewater treatment plants in which expansion is limited. However, the full incorporation of pre-treatment techniques in full-scale wastewater treatment plants still demands more information about their impacts on the overall economics, as mentioned above.

Finally, pre-treatments are sometimes complex unit operations, to be inserted in the already intricated process of urban water management. The fact that most pre-treatment techniques commonly result in increased process complexity to obtain limited benefits, draws the attention towards the necessity of wastewater treatment methods that not only focus on sanitation, but also on the avoidance (or at least minimization) of residuals such as WAS. Nonetheless, at present, the CAS process is to remain the standard technology, at least in most parts of the world. The consideration of WAS being a raw material, or a process to more actively incorporate residual mass and energy as resource into biogenic cycles, remains another possible management strategy. Such approach goes far beyond the direct application of digested WAS in agriculture, which in addition of being controversial due to genuine concerns about safety, has proven to be ineffective as a management tool. Instead, a possibility is to develop a process to extract biopolymers, such as humic matter, as well as nutrients from WAS. In other words, to engineer and operate CAS reactors not only as water purifiers but as fabrics of soil conditioners, nutrients, and other raw materials.

6.2 Effects of low-temperature thermal pre-treatment combined with the addition of H_2O_2 on the bioconversion of WAS to methane.

Regarding the performance of thermal pretreatment at 70 °C with H_2O_2 , the experiments conducted at both lab and pilot scale generally resulted in reproducible results.

It was found that WAS pre-treatment at 70 °C and a dose of 15 $\text{mgH}_2\text{O}_2/\text{gTS}$ at an application time of 30 min, resulted in a slight increase in the methane production rate. On the other hand, there were inconclusive results in terms of an increase in the total biochemical methane production (Chapters 3 and 4). In contrast to other pre-treatment conditions, the chosen settings did not produce recalcitrant soluble COD (Chapter 3). Moreover, the application of the researched pre-treatment together with compartmentalized digestion increased the applicable OLR, which was translated into a decrease in SRT from 23 to 15 days during the pilot-scale experiment. On the other hand, a negative effect on dewaterability of the digestate was observed, with higher consumption of conditioning agent to reach the same cake solids concentration as the non-treated samples.

Since a combination of pre-treatment methods was applied, the knowledge of the individual contribution of each pre-treatment was relevant for the objectives of the present study. It was found that the thermal stage provoked most of the solubilization of extractable protein, carbohydrates and humic substances in WAS (Chapter 4). The addition of H_2O_2 to thermally-treated WAS resulted in slightly further solubilization of proteins and carbohydrates but slightly decreased the concentration of humic substances, which was hypothesized to be the result of mineralization. It was found that the additional solubilization as a result of the addition of H_2O_2 did not result in changes in VFA production and BMP of

pre-treated WAS. In other words, the addition of H₂O₂ did not increase the production of biogas via *biochemical* conversions.

Finally, the addition of H₂O₂ to WAS at 70 °C coincided with a decrease in the apparent viscosity of WAS. The modification of other rheological parameters, such as consistency index, loss modulus, and yielding stress, suggested that WAS increased its ability to flow because of the addition of H₂O₂. Such results were successfully replicated with samples from two other WWTPs. Very likely, this drop in viscosity of pre-treated WAS enhanced the overall WAS digestibility. Previous research demonstrated that the viscosity of digestate played a relevant role in the rheology and mixing conditions of the digesters (Chapter 4). Thus, in chapter 4, it was speculated that the decrease in WAS viscosity, resulting from H₂O₂ addition, might have resulted in a better mass-transfer under non-ideally mixed anaerobic digestion and, subsequently, in an increased methane production rate. Thus, while H₂O₂ was not able to increase the BMP via a chemical mechanism (Figure 4.6a), it might have been able to enhance the WAS digestibility via a *physical* mechanism by making the digestate less viscous, facilitating its mixing during digestion under non-ideal conditions. However, a dedicated experiment to support or reject this speculation was not performed, which constitutes a limitation of this study.

6.3 Possible mechanisms underlying the effects of low-temperature thermal pre-treatment combined with the addition of H₂O₂ on the increased bioconversion of WAS to methane.

The exact reasons behind the decrease in viscosity of pre-treated WAS remain unclear. However, the formation of hydroxyl radicals via the Fenton’s reagent, the decrease in particle size of WAS, and the combination of H₂O₂ with the conditioning agent, were discarded as the causes (Chapter 4). An experiment was conducted by pre-treating model molecules of proteins, humic substances, and carbohydrates, which are the most prevalent types of biopolymers in WAS. The results showed that, among collagen, humic acid and cellulose, only cellulose decreased its viscosity after its interaction with H₂O₂ at 70 °C (Figure S4-17). Thus, it was hypothesized that the interaction between carbohydrates and H₂O₂ could have been a possible reason for the observed rheological modifications of the entire WAS matrix.

Based on the results of Chapter 4, it was found that the effects of H₂O₂ on WAS depended on the interaction with temperature. Thus, the mechanism shown in Table 6.1 was proposed:

Table 6.1 Possible mechanism of low-temperature thermal pre-treatment with H₂O₂.

Description	Visualization
-------------	---------------

Step #1. The exposure of WAS to thermal pre-treatment increased the concentration of extractable EPS by conveying the tightly-bound EPS to the soluble fraction. The latter was probably the reason of the observed increase in k_{CH_4} during anaerobic digestion.

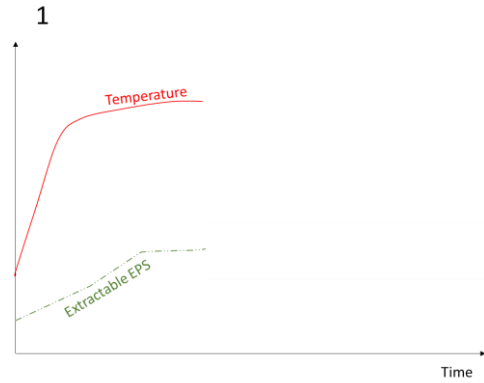

Step #2. Temperature at 70 °C inactivated the catalase prior to the addition of H_2O_2 ; thus, minimizing its conversion to water and oxygen.

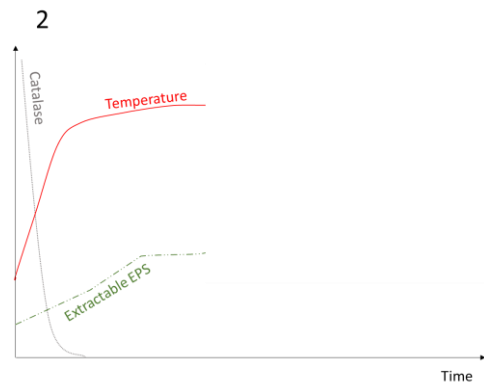

Step #3. The application of temperature decreased the viscosity of WAS in a first stage, which facilitated the mixing of WAS with H_2O_2 .

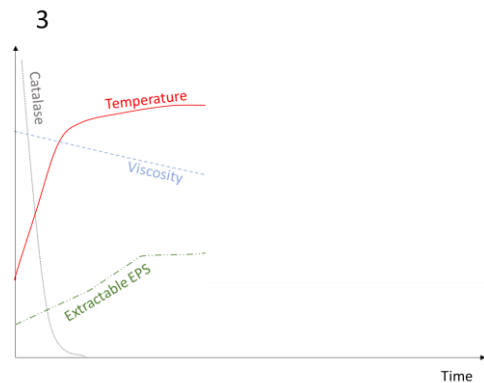

Step #4. The addition of H_2O_2 further decreased the viscosity of WAS and slightly increased the concentration of extractable EPS, thus potentiating the effects of temperature at 70 °C.

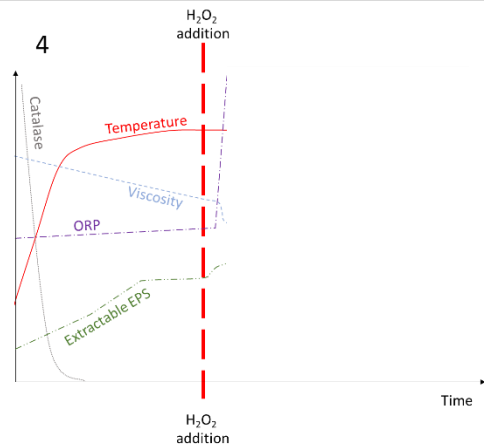

Step #5. Keeping the temperature at 70 °C speeded up the decomposition of H₂O₂ and its possible formed oxidizing derivatives, as suggested by the observed drop in the redox potential. The ORP drop to reducing conditions avoided the entrance of an oxidizing stream to the anaerobic digester.

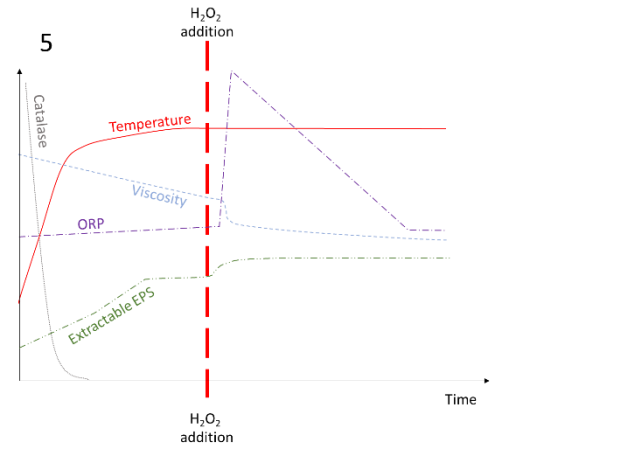

6.3.1 Lab-scale implication

Overall, the presented results suggest that the mixing conditions play a key role for the reliable determination of the methane production rate and SMP of WAS with >4%TS, even in lab-scale tests. Figure 4.6 illustrates the very relevant role that the mixing equipment had on the results of the SMP tests. Thus, it was inferred that some of the inconclusive and sometimes contradictory results reported for BMP in literature (Chapter 2), and along some of the preliminary experiments in Chapters 3 and 4, were caused by improper mixing, resulting in deficient mass-transfer during BMP assays. For instance, the accurate but imprecise BMP readings obtained when individual mixing motors (AMPTS-II) were used during digestion (Figure 4.6b), could be the result of differences in the mixing energy that each motor delivered to the sample (Chapter 4). Conceptually, this case is represented in Figure 6.1a. On the other hand, inaccurate but precise results (Figure 6.1b) were obtained when the oscillatory shaking table was used for mixing. The used orbital oscillator was expected to provide the same mixing power to all the samples, leading to precise results; however, the mixing power was not sufficient, causing inaccuracy. However, none of the used mixing modes resulted in accurate and precise values (Figure 6.1c), due to limitations of the mixing equipment.

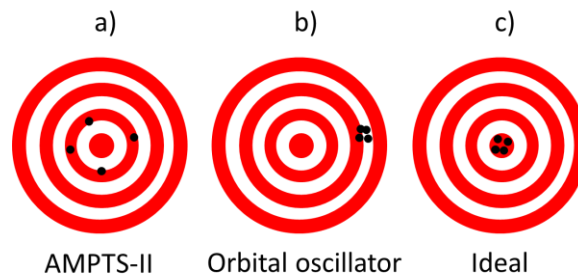

Figure 6.1. Cases of accuracy and precision in BMP assays.

Recently, considerable effort has been dedicated via discussions, workshops, and research articles, to improve both reproducibility and standardization of BMP tests (Hafner et al., 2020; Holliger et al., 2016; Koch et al., 2019). However, the effect of mixing and the impact of rheology of concentrated substrates, which might result in incorrect estimation of the BMP and kinetic constants used for modelling and for decision-making, has been barely addressed and needs further evaluation for proper interpretation of the results of WAS AD processes.

6.4 Influence of the composition of activated sludge on the effectiveness of pre-treatment.

Pre-treatment methods have been applied to WAS instead of primary sludge since the latter is assumed to be easier to bioconvert, while it is less susceptible to pre-treatment methods due to its nature. Probably for the same reasoning, it has been assumed that WAS, grown at short SRT, is inherently easier to biodegrade than WAS characterized by a long SRT. Therefore, the effectiveness of pre-treatment is expected to be more noticeable for long SRT WAS. The results of Chapter 5 suggest that in addition to sludge age, the sludge composition was also relevant for the effectiveness of pre-treatment, at least for the here researched low-temperature pre-treatment with the addition of H₂O₂. Results showed that growth media had a distinct effect on the methane production rate and extent of the grown sludge. In other words, during AD, the methane production from WAS is in accordance to the type of substrate in which the WAS was produced. The latter was verified by applying the pre-treatment to lab-grown sludge, grown under different conditions.

Although it was not possible to clearly link the observed effects to any of the constituents of the growth media, the change in response to pre-treatment coincided with i) an increase in the monovalent-to-divalent ratio of metals in the sludge matrix and ii) with the change in humic acid concentration that may have acted as chelating agent. Based on these results, it was hypothesized that the concentration, speciation, and bioavailability of the metals embedded in the sludge matrix might be relevant to estimate the bioconversion of pre-treated sludge to methane during anaerobic digestion, at least for pre-treatment conditions researched in this thesis.

The experimental conditions developed in Chapter 5 resulted in the cultivation of sludge with characteristics comparable to the WAS from one of the full-scale WWTPs. It should be noted that previous attempts to cultivate lab-grown sludge had resulted in WAS samples that were very labile. In addition, pre-treatment on that sludge was ineffective or even prejudicial for increasing SMP. However, since results from repetitive experiments show that the response to pre-treatment of lab-grown sludge using the new medium recipe is similar to the response observed in full-scale processes, this recipe could be used as a 'standard' substrate for WAS cultivation. With the use of standardized lab-grown sludge, the large variation in treatment results, which is linked to the inherent variation in composition of full-scale WAS, can be minimized. Working with defined lab-grown sludge may further help to elucidate which specific constituents of the sludge are affected by pre-treatment and to what extent. The under such conditions obtained results would allow developing strategies to focus on the recalcitrant constituents to reach a higher WAS bioconversion or other interesting results.

6.5 Concluding remarks

Summarizing, the main contributions of the present research to the understanding of WAS pre-treatment are as follows: Firstly, the bibliographical study gives a factual compilate not only of the effects but also of the relevant operational parameters of several pre-treatment techniques of distinct nature. It also addresses the effects on specific parameters and constituents of WAS, which are relevant for their subsequent anaerobic digestion, such as methane production potential and dewaterability. The chosen approach is considered to be useful for both scientists and practitioners working with WAS pre-treatments. Secondly, the upscaling of the researched pre-treatment technique from lab- to pilot-scale

showed reproducibility of the observations, which implies possibilities for further upscaling to full-scale conditions. Thirdly, since a combination of two pre-treatment methods was used, the present research revealed how each pre-treatment technique contributed to the observed performance. Moreover, it was possible to propose and reject some mechanisms explaining the results. Finally, it was experimentally proven that the growth media impacted the BMP of lab-grown sludge. It was clearly demonstrated that WAS from full-scale installations is far from a 'standardized substrate' and it was observed that the application of WAS pre-treatment might result in differences in SMP, dependent on the WAS characteristics. In this regard, the present study also highlights the need for WAS cultivation in lab reactors, using standardized media, which might better predict the biogas production from full-scale WAS. Such standardized media for lab-grown sludge also allows for comparative research on different WAS pre-treatment techniques under distinct operational conditions. As a consequence, it allows for a more equitable comparison of the effects and mechanisms of pre-treatments at different conditions or of distinct nature (chemical, mechanical, and/or biological). However, the cultivated sludge is still pending of being validated under pre-treatments of other nature.

Biochemical conversions and mass-transfer phenomena were shown to be strongly interrelated during the SMP assays. The current thesis put forward the possibility that the assayed pre-treatment increased the SMP due to an improved rheology, instead of a biochemical reaction, as is commonly acknowledged in scientific literature. It is therefore recommended to conduct experiments that aim to separate the biochemical and rheological effects of pre-treatment to further reveal the underlying causes of the observed effects.

6.6 References

- Hafner, S., Fruteau, H., Koch, K., Holliger, C., 2020. Improving inter-laboratory reproducibility in measurement of biochemical methane potential (BMP). *Water* 12. <https://doi.org/10.3390/w12061752>
- Holliger, C., Alves, M., Andrade, D., Angelidaki, I., Astals, S., Baier, U., Bougrier, C., Buffière, P., Carballa, M., De Wilde, V., Ebertseder, F., Fernández, B., Ficara, E., Fotidis, I., Frigon, J.C., De Lacroix, H.F., Ghasimi, D.S.M., Hack, G., Hartel, M., Heerenklage, J., Horvath, I.S., Jenicek, P., Koch, K., Krautwald, J., Lizasoain, J., Liu, J., Mosberger, L., Nistor, M., Oechsner, H., Oliveira, J.V., Paterson, M., Pauss, A., Pommier, S., Porqueddu, I., Raposo, F., Ribeiro, T., Pfund, F.R., Strömberg, S., Torrijos, M., Van Eekert, M., Van Lier, J., Wedwitschka, H., Wierinck, I., 2016. Towards a standardization of biomethane potential tests. *Water Sci. Technol.* 74, 2515–2522. <https://doi.org/10.2166/wst.2016.336>
- Koch, K., Hafner, S.D., Weinrich, S., Astals, S., 2019. Identification of critical problems in biochemical methane potential (BMP) tests from methane production curves. *Front. Environ. Sci.* 7, 1–8. <https://doi.org/10.3389/fenvs.2019.00178>
- Wei, P., 2021. Characterisation of Sludge Rheology and Sludge Mixing in Gas-mixed Anaerobic Digesters. Delft University of Technology.

Acknowledgements

I thank the people of Mexico (by means of the Mexican National Council of Science and Technology, CONACyT) for providing most of the economic resources and administrative efforts to perform my doctoral study.

I appreciate the assistance of the operators of Harnaschpolder, Nieuwgraaf, and Kralingseveer wastewater treatment plants: Paul, Abdel, Roland, Sander and Martijn. Also, to André Visser from Royal Haskoning DHV for his advice. Similarly, I deeply thank the assistance of the laboratory technicians in the Water Lab, particularly Armand and Mohammed, and from the department secretaries, Mariska, Tamara and Rielle. They all made my stay in the Netherlands cozier.

I also thank my promotors for their guidance: Jules, for letting me in his research group and for his accurate observations and scientific judgement; and Merle, for her trust, warm advice and patience during my darkest times. Also, I am profoundly grateful to have shared the office with Alexander Hendriks, whom has been the most influential individual during my doctoral venture.

I am deeply thankful to my colleagues in the lab, particularly Javier, who always offered interesting and intellectually defying discussions; Hongxiao, for his good vibes, availability and for introducing me to the Water Lab; Victor, who has always been a good-hearted guy; and Pamela for her warm friendship. I thank Patricia and Isaac for our friendship.

In addition, to my colleagues Andrea; Antonella; Bruno; Carina; Cuijie; Emiel; Julian; Lenno; Magela; Max; Niels; Peng; Saqr; Sara; Steef; and Xuedong. They have formed a thriving and vibrant working environment.

I thank my sister Violeta and my brother Alex: they have been a source of wisdom and have always been there for offering support. I have already dedicated this work to my parents, Armida and Javier, for their love and generosity. Thanks to my wife Mariana for her trust and thrust, I am eager to continue discovering the world with our children.

Thanks to all the people who have left a mark on me. All these people have shaped me in one or other way and the are part of this work. Finally, I thank what some people call 'God' for the experience of what we call 'life'.

List of publications

Peer-reviewed research articles:

- Gonzalez, A., Hendriks, A.T.W.M., van Lier, J.B., de Kreuk, M., 2018. *Pre-treatments to enhance the biodegradability of waste activated sludge: Elucidating the rate limiting step*. Biotechnol. Adv. 36, 1434–1469. <https://doi.org/10.1016/j.biotechadv.2018.06.001>
- Gonzalez, A., Guo, H., Ortega-Ibáñez, O., Petri, C., van Lier, J.B., de Kreuk, M., Hendriks, A., 2020. *Mild thermal pre-treatment of waste activated sludge to increase loading capacity, biogas production, and solids' degradation: A pilot-scale study*. Energies 13, 6059. <https://doi.org/10.3390/en13226059>.
- Gonzalez, A., Lier, J.B. Van, Kreuk, M.K. De, 2021. *The role of growth media on composition, bioconversion and susceptibility for mild thermal pre-treatment of waste activated sludge*. J. Environ. Manage. 298, 113491. <https://doi.org/10.1016/j.jenvman.2021.113491>.
- Gonzalez, A., van Lier, J.B., de Kreuk, M., 2022. *Effects of mild thermal pre-treatment combined with H₂O₂ addition on waste activated sludge digestibility*. Waste Management 141, 163-172. Doi: 10.1016/j.wasman.2022.01.017.

Participations in conferences:

- Gonzalez, A., Hendriks, A.T.W.M., van Lier, J.B., de Kreuk, M., 2017. *Assessment of 70°C pre-treatment for enhancing secondary sludge anaerobic digestion: impact of monovalent cations addition*. IWA Specialist Conference on Sludge Management: SludgeTech 2017. London. U.K. 2017.
- Gonzalez, A., Hendriks, A.T.W.M., van Lier, J.B., de Kreuk, M., 2018. *Energy balance and biodegradability of pre-treatments for waste activated sludge: a literature-based comparison*. Sludge Management in Circular Economy: SMICE 2018. Rome, Italy. 2018.
- Gonzalez, A., Hendriks, A.T.W.M., van Lier, J.B., de Kreuk, M., 2019. *A bibliometric analysis on what really matters in AD pre-treatment research*. 16th World Congress on Anaerobic Digestion: AD16. Delft, The Netherlands. 2019.
- Gonzalez, A., van Lier, J.B., de Kreuk, M., 2022. *The role of growth media on composition, bioconversion and susceptibility for mild thermal pre-treatment of waste activated sludge*. Specialised Workshop on pre-treatment techniques, 17th World Congress on Anaerobic Digestion: AD17. Ann Harbor, U.S.A. 2022.
- Gonzalez, A., van Lier, J.B., de Kreuk, M., 2022. *Effects of mild thermal pre-treatment combined with H₂O₂ addition on waste activated sludge digestibility*. 17th World Congress on Anaerobic Digestion: AD17. Ann Harbor, U.S.A. 2022.

Biography

I was born in Ensenada, Mexico, on April 23rd 1987. I obtained a Bachelor Degree in Civil Engineer in Universidad Autónoma de Baja California in 2010. During my bachelor studies I performed internships in an international port firm and in the California Department of Transportation (Caltrans). In 2014, I obtained my Master Degree with the thesis '*Assessment of a dynamic membrane system for anaerobic wastewater treatment*'.

I have worked in urban planning as geographical information systems' analyst and as a supervisor of civil engineering project for some private firms. I was also a project manager in the Mexican Water Commission (Conagua), supervising sanitation projects such as sewage-pipe laying, treatment plants and remediation of a lake. I have peer-reviewed for journals such as Water Research, Scientific Reports, Science of Total Environment, Chemosphere and BMC Biotechnology. Recently, I have funded, a small research-based firm looking to apply integrated water management practices in small-scale such as individual houses. My interests are the development of low-cost water-management technologies; the understanding of ecological systems; and philosophy of science.

Supplementary Information

Supplementary information can be accessed by repository:

Gonzalez, Adrian (2022), "Supplementary Information of Dissertation Adrian Gonzalez", Mendeley Data, V1, doi: [10.17632/69h2kg6hmt.1](https://doi.org/10.17632/69h2kg6hmt.1)