

## A 2m-Range 711uW Body Channel Communication Transceiver Featuring Dynamically-Sampling Bias-Free Interface Front End

Gu, Guanjie ; Yang, Changgui; Li, Zhuhao ; Feng, Xiangdong ; Chang, Ziyi; Wang, Ting-Hsun ; Zhang, Yunshan; Luo, Yuxuan; Zhang, Hong ; Wang, Ping

**DOI**

[10.1109/A-SSCC56115.2022.9980620](https://doi.org/10.1109/A-SSCC56115.2022.9980620)

**Publication date**

2022

**Document Version**

Final published version

**Published in**

Proceedings of the 2022 IEEE Asian Solid-State Circuits Conference (A-SSCC)

**Citation (APA)**

Gu, G., Yang, C., Li, Z., Feng, X., Chang, Z., Wang, T.-H., Zhang, Y., Luo, Y., Zhang, H., Wang, P., Du, S., Chen, Y., & Zhao, B. (2022). A 2m-Range 711uW Body Channel Communication Transceiver Featuring Dynamically-Sampling Bias-Free Interface Front End. In *Proceedings of the 2022 IEEE Asian Solid-State Circuits Conference (A-SSCC)* IEEE. <https://doi.org/10.1109/A-SSCC56115.2022.9980620>

**Important note**

To cite this publication, please use the final published version (if applicable).  
Please check the document version above.

**Copyright**

Other than for strictly personal use, it is not permitted to download, forward or distribute the text or part of it, without the consent of the author(s) and/or copyright holder(s), unless the work is under an open content license such as Creative Commons.

**Takedown policy**

Please contact us and provide details if you believe this document breaches copyrights.  
We will remove access to the work immediately and investigate your claim.

***Green Open Access added to TU Delft Institutional Repository***

***'You share, we take care!' - Taverne project***

**<https://www.openaccess.nl/en/you-share-we-take-care>**

Otherwise as indicated in the copyright section: the publisher is the copyright holder of this work and the author uses the Dutch legislation to make this work public.

## A 2m-Range 711uW Body Channel Communication Transceiver Featuring Dynamically-Sampling Bias-Free Interface Front End

Guanjie Gu<sup>1</sup>, Changgui Yang<sup>1</sup>, Zhu hao Li<sup>1</sup>, Xiangdong Feng<sup>1</sup>,  
Ziyi Chang<sup>1</sup>, Ting-Hsun Wang<sup>1</sup>, Yunshan Zhang<sup>1</sup>, Yuxuan Luo<sup>1</sup>,  
Hong Zhang<sup>1</sup>, Ping Wang<sup>1</sup>, Sijun Du<sup>2</sup>, Yong Chen<sup>3</sup>, and Bo Zhao<sup>1\*</sup>

<sup>1</sup> Zhejiang University, Hangzhou, China

<sup>2</sup> Delft University of Technology, Delft, Netherlands

<sup>3</sup> University of Macau, Macao, China

\* Corresponding Author: Bo Zhao (zhaobo@zju.edu.cn)

Body Channel Communication (BCC) offers a low-loss signal transmission medium for ultra-low-power wearable devices on human body [1]. However, the effective communication range on human body is limited to less than 1m in the state-of-the-art BCC transceivers [2], where the signal loss at the interface of body surface and BCC receiver remains to be one of the main bottlenecks. The limited communication range has blocked the popularization in many WBAN applications, such as signal transmission from an intelligent insole to smart watch [3]. Relative to the high impedance of human body [4], the lower input impedance of BCC receiver induces significant signal loss. To reduce the interface loss, conventional interface front end (IFE) of BCC receivers was designed to be with a high input impedance [5], but the DC voltage bias decreased both the input impedance and signal gain of IFE.

There were two conventional typologies to implement the IFE of BCC transceivers, as shown in Fig.1: 1) Closed-loop IFE. Negative feedback was adopted to provide self-biasing DC voltages for cascaded IFE stages [3], as shown in Fig.1(a). However, the negative feedback reduced both the input impedance and the IFE gain, degrading the receiver sensitivity and communication range. For example, the IFE with negative feedback showed a voltage gain of 20dB, achieving a communication range of 15cm with 5mW power consumption [3]. 2) Gate-input IFE with DC bias. The input stage of IFE can be the gate terminal of a MOSFET [4], ensuring a high input impedance. However, biasing resistors are desired at the input of each stage to set the DC point, decreasing both the input impedance and front-end gain. As a result, the sensitivity of BCC receiver was degraded, and then the 6.44mW power consumption only extended the communication range to 20cm [4]. In addition, both the two conventional IFE techniques require big resistors to set the DC bias, as well as a mixer for down-converting, which enlarged the die area of BCC transceivers.

In this work, a dynamically-sampling IFE is proposed to extend the effective communication range of BCC transceivers with low power consumption: 1) The DC voltage bias is eliminated, resulting in a 90KOhm high input impedance to minimize the interface loss. 2) A 94dB RF-IF conversion gain is realized to improve the receiving (Rx) sensitivity with low power. 3) The IFE realizes the RF-IF conversion without any DC biasing resistor or down-converting mixer, reducing both the power consumption and die area.

The proposed dynamically-sampling IFE is shown in Fig.2, which is composed of high-gain Inverter-based amplifiers with feedback switches. The switches are controlled by the LO signal generated by a low-power phase-locked loop (PLL). The proposed IFE operates in a duty-cycled way composed by two phases, i.e. the holding phase and the sampling phase. In the holding phase, all the feedback switches are turned on, settling the DC points of the inverter-based amplifiers. In the sampling phase, all the feedback switches are shut off to configure the IFE to be a gate-input inverter chain with a 90KOhm high input impedance and a 94dB high voltage gain, while the DC points of all the nodes are still held by the parasitic capacitance without any biasing resistor. Meanwhile, the dynamically sampling down-converts the RF signals into an intermediate frequency, eliminating the use of a mixer. The 16MHz-24MHz FSK RF signal is sampled by a 26MHz LO clock, and then down-converted to an intermediate frequency ranging in 2MHz-10MHz, while the upper-band interferes (42MHz-50MHz tones) can be rejected by the subsequent filters. In this way, the IFE eliminates the use of big resistor and mixer compared to conventional methods, reducing the chip area.

The proposed IFE technique is implemented in an FSK BCC transceiver, as shown in Fig.3. The FSK signal is formed in the transmitter, including a 2MHz crystal oscillator, a PLL, two frequency dividers, a MUX, and a body driver. The BCC receiver is composed of the dynamically-sampling bias-free IFE, a 4-stage Sallen-Key low-pass filter (LPF), an Intermediate-frequency amplifier (IFA), an envelope detector, and a slicer. In the transmitting (Tx) mode, the PLL outputs a 48MHz frequency with a 2MHz crystal, which is divided into 24MHz and 16MHz frequency components. The baseband data controls the MUX to switch between the two frequencies, resulting in a 16MHz-24MHz FSK signal. Finally, a body driver is designed to send the FSK signal through human body. In the Rx mode, the IFE amplifies and down-converts the received FSK signal into a 2MHz-10MHz intermediate-frequency band. Subsequently, the 4-stage Sallen-Key LPF with 3MHz corner frequency is used to suppress the 10MHz component while passing the 2MHz sideband, changing the FSK signal into an AM waveform. Finally, an envelope detector is used to demodulate the AM signals, which is finally recovered into a '0-1' bit stream by the slicer.

The input impedance of IFE, receiver sensitivity, and transmitter spectrum are measured in Fig.4. The IFE presents an input impedance of 90KOhm at the central frequency of the Rx band, resulting in a low interface loss. The sensitivity and BER of the BCC transceiver chip are tested with a 500Kb/s PRBS-7 data stream. It shows that the receiver achieves a sensitivity of -104dBm (5mV peak value) at a BER of  $6 \times 10^{-5}$ . For the BCC transmitter, the output spectrum indicates an FSK signal with a peak amplitude of 1.2V.

We measure the communication BER at different forward ranges, backward ranges, ground sizes, and electrode-ground distances in Fig.5. A PRBS-7 bit stream is transferred through a 2m range, from the ankles to the wrist, where a pair of 3M medical electrodes are used for the contact of human body and BCC transceiver chips. Both the BCC transmitter and receiver are powered by a button battery to avoid the influence of power lines. Firstly, the forward path on the body surface is kept to be equal to the channel length of backward capacitive coupling. The measured BER versus the overall communication range shows that the BCC transceiver chip achieves a BER of  $2 \times 10^{-4}$  at 2m range. Secondly, the forward path is set to 2m, and the BER changes from  $5 \times 10^{-5}$  to  $2 \times 10^{-4}$  at a backward channel length of 30cm-2m. Thirdly, the measured BER is reduced from  $1.5 \times 10^{-3}$  to  $2 \times 10^{-5}$  as the ground plane of BCC transceiver is enlarged from 9cm<sup>2</sup> to 100cm<sup>2</sup>. Finally, the distance between signal electrode and ground is changed from 0cm to 20cm, resulting in a BER of  $4 \times 10^{-3}$  to  $2 \times 10^{-5}$  at a communication range of 2m. Therefore, the 2m range of proposed BCC transceiver can cover the communication on a whole human body.

The power breakdown of the BCC transceiver chip is shown in Fig.6, where the chip consumes 214.4uW power in TX mode and 457.2uW in the RX mode. In addition, the measurement results are summarized and compared to the state-of-the-art BCC transceivers. It shows that: 1) Our chip has achieved a 2m communication range, which is the longest among the works. 2) The total power consumption of Tx and Rx modes is reduced to 711uW, which is the lowest in the related works. 3) The proposed IFE technique achieves the best sensitivity due to the 90KOhm high input impedance and 94dB RF-IF conversion gain. The BCC transceiver chip is implemented in 55nm CMOS process, and the die photo and measurement setup are shown in Fig.7.

### Acknowledgement:

This work was supported by National Key R&D Program of China 2019YFB2204500, NSFC 61974130 and 62074135, and Key R&D Program of Zhejiang Province in China 2021C03002.

### References:

- [1] J. Bae, et al., "A 0.24-nJ/b Wireless Body-Area-Network Transceiver with Scalable Double-FSK Modulation," JSSC, 2012.
- [2] W. Saadeh, et al., "A 1.1-mW Ground Effect-Resilient Body-Coupled Communication Transceiver with Pseudo OFDM for Head and Body Area Network," JSSC, 2017.
- [3] S. Song, et al., "A 0.2-mW 2-Mb/s Digital Transceiver Based on Wideband Signaling for Human Body Communications," JSSC, 2007.

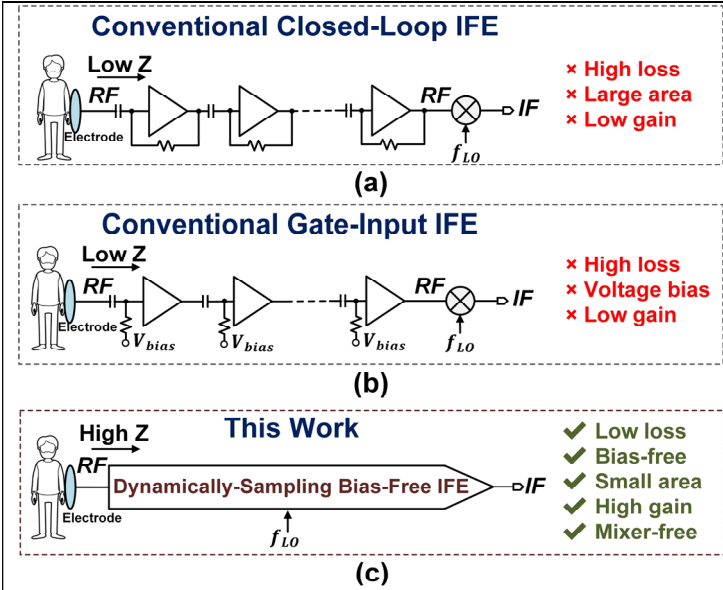

Fig. 1. Conventional interface front-end (IFE) and this work.

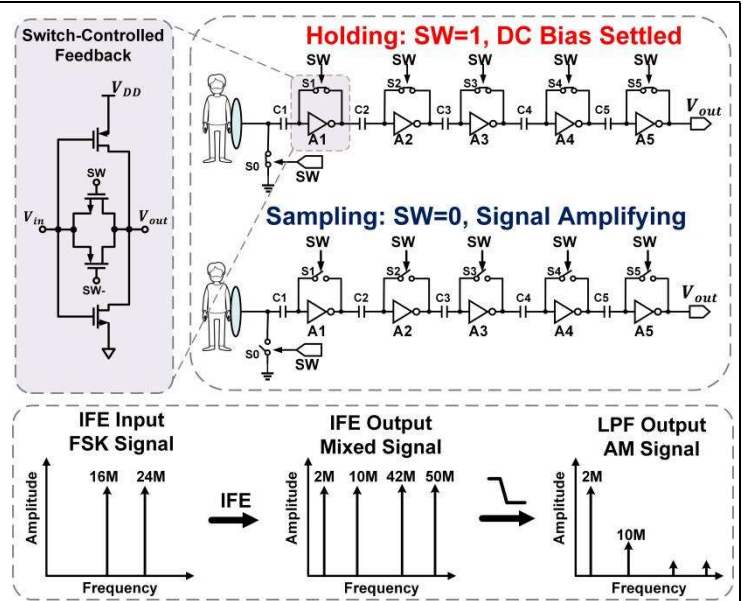

Fig. 2. Circuit details of proposed interface front-end (IFE).

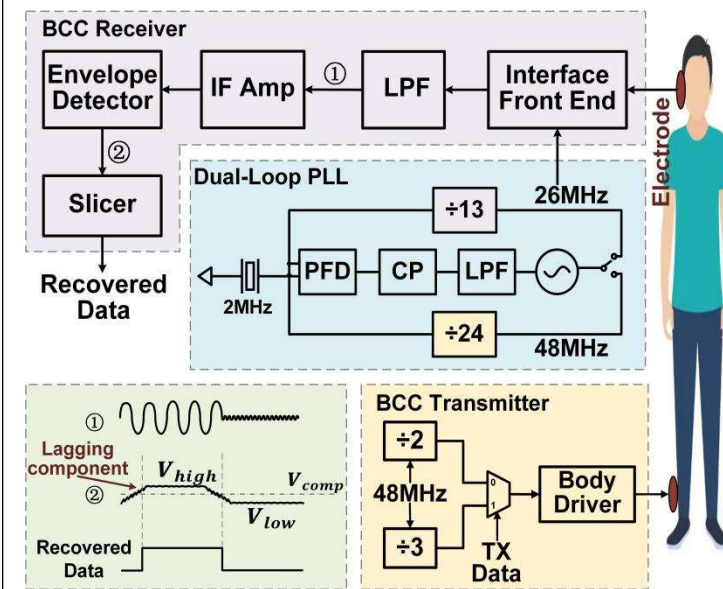

Fig. 3. System architecture of BCC transceiver.

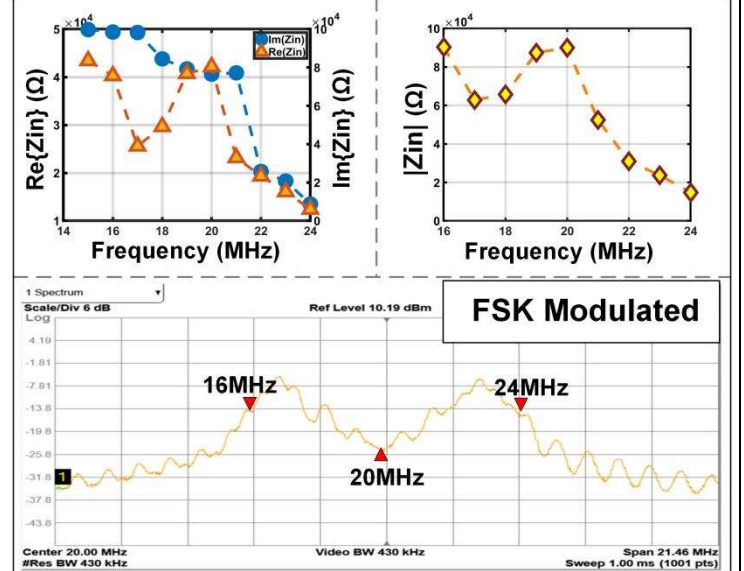

Fig. 4. Measured input impedance of BCC receiver and transmitting spectrum of BCC transmitter.

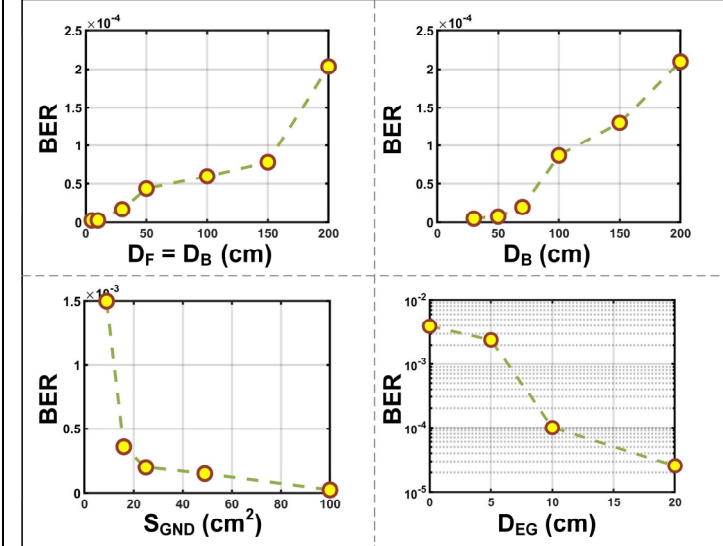
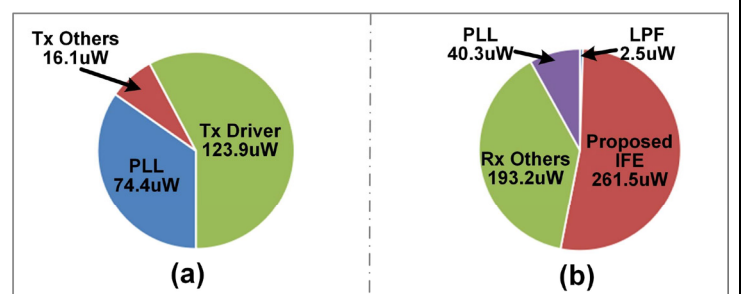

Fig. 5. Measured BER versus different parameters ( $D_F$ : Forward range,  $D_B$ : Backward distance,  $S_G$ : ground size, and  $D_{EG}$ : Electrode-to-ground distance).



	JSSC'17[7]	JSSC'19[6]	JSSC'20[4]	JSSC'19[8]	This Work
Process	65nm	65nm	0.18um	65nm	55nm
Data rate	1Mb/s	80Mb/s	240Kb/s	65k-5.25Mb/s	500Kb/s
Sensitivity	-78dBm	-60dBm	-98.9dBm	-72dBm	-104dBm
BER	$10^{-7}$	$10^{-5}$	NA	$10^{-7}$	$10^{-5}$ @ 1m & $10^{-4}$ @ 2m
Tx+Rx Power	2.5mW	9.7mW	5.9mW	4.14mW	0.711mW
Tx Power	1.1mW	1.7mW	0.9mW	3.52mW	0.214mW
Rx Power	1.4mW	8mW	5mW	620uW	0.497mW
Voltage	1.1V	1V	0.6V	NA	1.2V
Core area	2.13mm <sup>2</sup>	16mm <sup>2</sup>	0.99mm <sup>2</sup>	0.6724mm <sup>2</sup>	0.123mm <sup>2</sup>
Bit energy	2.5nJ/bit	0.122nJ/bit	3.8nJ/bit	4.2nJ/bit	1.3nJ/bit
Range	30cm	20cm	20cm	NA	2m

Fig. 6 Power breakdown and performance comparison.



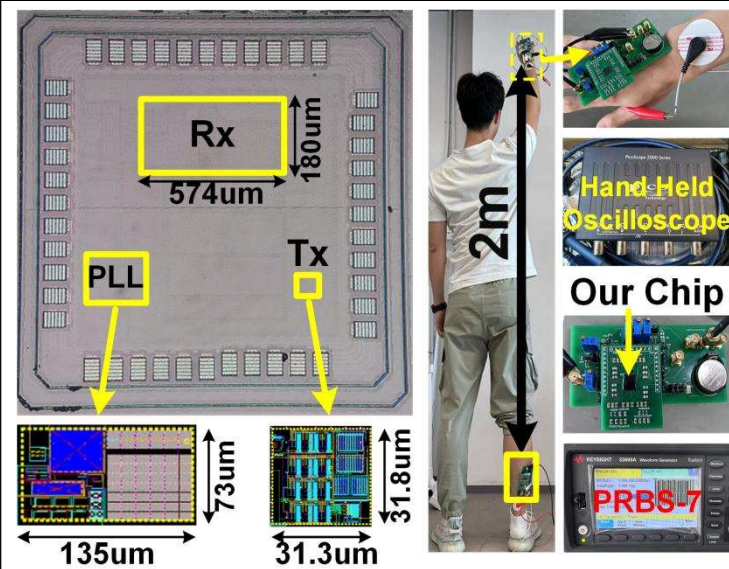

Fig. 7. Die photo and experimental setup.

#### Additional References:

- [4] J. Jang, et al., "Wireless Body-Area-Network Transceiver and Low-Power Receiver with High Application Expandability," JSSC, 2020.
- [5] J. Lee, et al., "30.7 A 60Mb/s wideband BCC transceiver with 150pJ/b RX and 31pJ/b TX for emerging wearable applications," ISSCC, 2014.
- [6] J. Jang, et al., "A Four-Camera VGA-Resolution Capsule Endoscope System With 80-Mb/s Body Channel Communication Transceiver and Sub-Centimeter Range Capsule Localization," JSSC, 2019.
- [7] W. Saadeh, et al., "A Pseudo OFDM With Miniaturized FSK Demodulation Body-Coupled Communication Transceiver for Binaural Hearing Aids in 65 nm CMOS," JSSC, 2017.
- [8] B. Zhao, et al., "A Low-Power Compact IEEE 802.15.6 Compatible Human Body Communication Transceiver With Digital Sigma-Delta IIR Mask Shaping," JSSC, 2019.