



Delft University of Technology

A Systematic Methodology for the Synthesis of Advanced Reactive Distillation Technologies

Pazmiño-Mayorga, Isabel; Jobson, Megan; Kiss, Anton A.

DOI

[10.1021/acs.iecr.2c04540](https://doi.org/10.1021/acs.iecr.2c04540)

Publication date

2023

Document Version

Final published version

Published in

Industrial and Engineering Chemistry Research

Citation (APA)

Pazmiño-Mayorga, I., Jobson, M., & Kiss, A. A. (2023). A Systematic Methodology for the Synthesis of Advanced Reactive Distillation Technologies. *Industrial and Engineering Chemistry Research*, 62(14), 5907-5928. <https://doi.org/10.1021/acs.iecr.2c04540>

Important note

To cite this publication, please use the final published version (if applicable). Please check the document version above.

Copyright

Other than for strictly personal use, it is not permitted to download, forward or distribute the text or part of it, without the consent of the author(s) and/or copyright holder(s), unless the work is under an open content license such as Creative Commons.

Takedown policy

Please contact us and provide details if you believe this document breaches copyrights. We will remove access to the work immediately and investigate your claim.

A Systematic Methodology for the Synthesis of Advanced Reactive Distillation Technologies

Isabel Pazmiño-Mayorga,* Megan Jobson, and Anton A. Kiss*



Cite This: *Ind. Eng. Chem. Res.* 2023, 62, 5907–5928



Read Online

ACCESS |



Metrics & More



Article Recommendations



Supporting Information

ABSTRACT: This study is the first to provide a systematic approach to assessing the potential of advanced reactive distillation technologies to expand the applicability of reactive distillation. The work presented here focuses on the synthesis of advanced reactive distillation technologies, proposing a conceptually based methodology for early-stage screening. The methodology uses basic thermodynamic and kinetic data to navigate a decision-making flowchart in four steps: compositions and splits, basic properties and operating windows, kinetics, and phase equilibria. The results qualify advanced reactive distillation technologies as advantageous, technically feasible, or not applicable. Five industrially relevant case studies illustrate the application of the methodology to develop preliminary process flowsheets. The proposed methodology aims to guide technology selection using basic data while providing flexibility to meet the objectives of the design problem. This methodology contributes to integrating a technology-oriented approach normally followed in process intensification studies into a process systems engineering approach by developing a conceptual flowsheet in the early stages of process design.

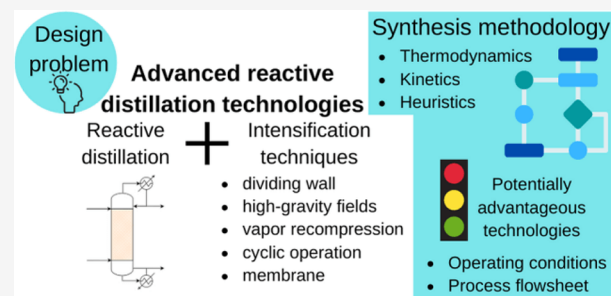

1. INTRODUCTION

Traditional approaches for chemical process synthesis and design typically rely on the use of conventional unit operations that perform a single task. This inherent limitation results in configurations containing numerous units and recycle streams. Consequently, processes become complex and costly, often facing difficulties in meeting current and future challenges for the chemical and biochemical industries. Therefore, the process development community requires novel approaches, especially in the early stages when numerous processing options need to be rapidly evaluated with limited data.

Process intensification (PI) adds a disruptive shift toward innovative technologies by addressing the phenomena at various stages without confining the alternatives to the classical “unit operation” concept.¹ Synergy, one of the PI domains, exploits the interactions of combining two or more functions in a single processing step, such as reaction and separation in reactive distillation (RD). A synergistic effect occurs when the reaction improves separation by overcoming azeotropes, while the separation improves the reaction by increasing reaction rates, overcoming chemical equilibrium and improving selectivity.² Other benefits of RD include capital and operating cost savings, reduced plant footprint, and better environmental performance when compared to a conventional reactor distillation sequence.³ However, RD requires that the reaction and separation operating conditions overlap, which restricts its wider use.⁴ Advanced reactive distillation technologies (ARDT) integrate the benefits of RD and additional PI features, which can enlarge the range of potential operating conditions, enabling a larger

overlap between reaction and separation while decreasing the number of units due to the integrated functions.⁵ The ARDT in scope are reactive dividing-wall column (R-DWC), catalytic cyclic distillation (CCD), reactive internally heat-integrated distillation (R-HIDiC), reactive high-gravity distillation (R-HiGee), and membrane-assisted reactive distillation (MA-RD).

This work proposes a conceptually based systematic approach for early screening of ARDT. This approach aims to guide the selection of feasible technologies during the development of flowsheets to address the design problem for a specified chemical system. Challenges for the application of ARDT are discussed in the problem statement section. Then, the main features and insights for process synthesis for R-DWC, CCD, R-HIDiC, R-HiGee, and MA-RD are described. The research approach includes the development, scope, structure, and application of the methodology, including interpretation of results. Finally, five case studies demonstrate the application of the methodology to identify potential configurations, and results of rigorous simulations available in the literature serve to confirm their feasibility.

Received: December 18, 2022

Revised: February 14, 2023

Accepted: March 16, 2023

Published: March 31, 2023



2. PROBLEM STATEMENT

Industrial applications of ARDT are extremely scarce. Although conventional RD is established for equilibrium-limited reaction systems,^{6,7} the lack of robust methods and tools for process design and simulation and of pilot and industrial tests limits the uptake of ARDT.⁴ Synthesis methods that result in a conceptual flowsheet, following a process systems engineering approach, are also lacking.⁸ Methods for evaluating the feasibility of RD in a given context are limited to standalone units^{9–11} or reactive separation systems, including conventional and intensified units.^{12,13} However, synthesis and design of processes that apply ARDT have hardly been explored. In this work, the research question relates to whether a structured flowchart can be developed to identify which, if any, ARDT are best suited to exploit a given chemical reaction to produce a desired product.

Previous studies to develop reaction or reaction–separation processes on a laboratory scale or through simulation tend to oversimplify complex features that can potentially affect operation. These features include impurities that interact with other species, dilute feeds, constraints for materials of construction, thermal and chemical stability of the participating components, undesired side reactions, and azeotropes. However, by generalizing features of the operation and equipment, the methods and results of earlier studies can highlight decision points and relevant characteristics of the process system that could guide the selection of technologies.

This study proposes a systematic conceptually based methodology for initial evaluation of ARDT during flowsheet development. The methodology uses basic thermodynamic and kinetic properties, applying first principles and heuristics to qualitatively assess the application of ARDT. Overall, it aims to enable informed decisions prior to detailed process design.

3. ADVANCED REACTIVE DISTILLATION TECHNOLOGIES: MAIN FEATURES AND INSIGHTS FOR PROCESS SYNTHESIS

3.1. Reactive Dividing-Wall Column (R-DWC). A reactive dividing-wall column combines already intensified technologies: a dividing-wall column and reactive distillation in a single vessel.¹⁴ Figure 1a illustrates the concept of an R-DWC containing one reactive section in the feed side and a dividing wall located in the middle. Other arrangements concerning the location and number of feed streams, dividing walls, and reactive sections are possible.^{14,15} R-DWC allows at least three outlet streams, facilitating removal of intermediate-boiling components and recycling of reactants both internally (via reflux and boil-up) and externally in the draw stream when conversion is incomplete. The dividing wall and side streams change the composition profiles within the column, compared to a conventional RD column. Therefore, a reaction could be promoted or prevented because of the change in composition on that stage relative to RD. This is relevant when undesired parallel reactions reduce selectivity toward the main product. R-DWC can operate under vacuum, at and above atmospheric pressure,¹⁶ allowing for a wide range of conditions that could favor reactions in the liquid phase, although operation at a single pressure can limit the application of R-DWC. Technology readiness based on pilot and industrial experience is intermediate.⁴

3.2. Reactive High-Gravity Distillation (R-HiGee). Reactive high-gravity distillation combines intensified gravitational force to enhance mass, heat, and momentum transfer to

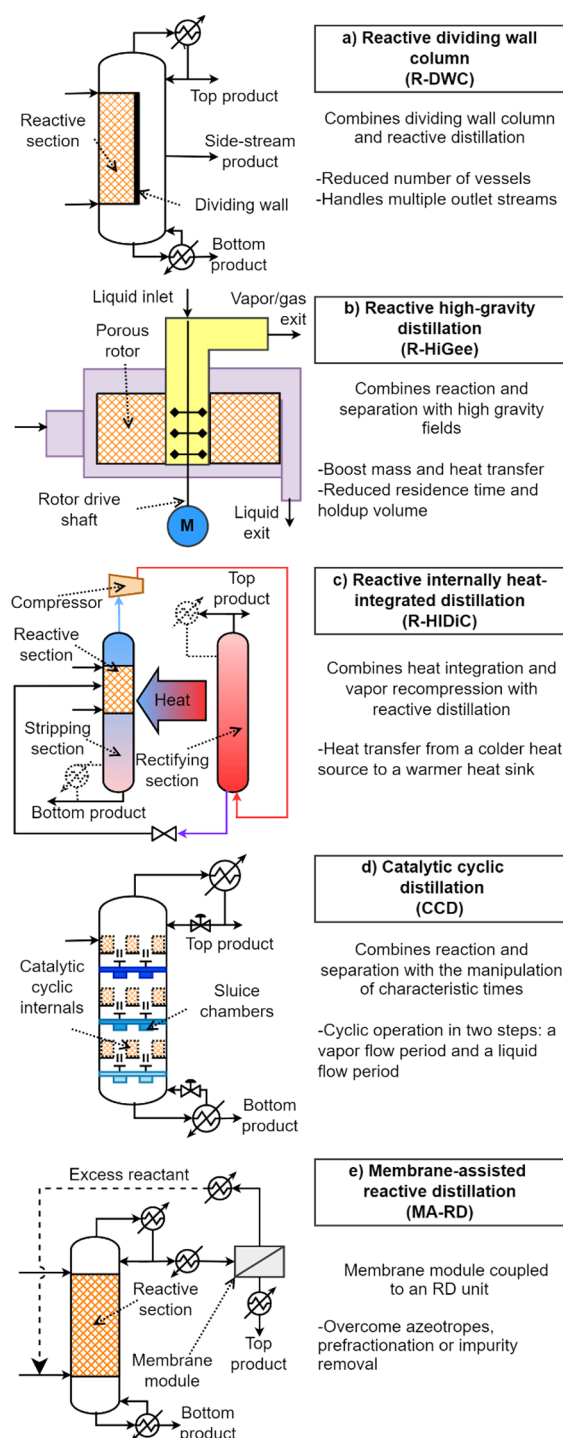

Figure 1. (a–e) Main features of five advanced reactive distillation technologies.

favor phase separation and reaction (Figure 1b).¹⁷ Consequently, the required residence time and holdup volumes are reduced, resulting in smaller equipment. Rotating packed beds have been identified as a suitable HiGee contactor to perform RD.^{4,17,18} This technology is particularly suitable for diffusion-limited systems (e.g., high viscosity) and when the reaction network includes series reactions, where desired products could be transformed into unwanted byproducts.¹⁹ Therefore, a narrow residence time distribution helps to achieve high selectivity to the desired product. The features of chemical

systems that are suited to R-HiGee are diffusion-limited liquids and fast reactions with secondary reactions in series. Rotating packed beds can be advantageous for high-pressure operation²⁰ and vacuum distillation.²¹ Although the industrial application of a rotating packed bed (RBP) for the production of hypochlorous acid has reached a high technology readiness level, R-HiGee is not yet considered a mature technology.¹⁸

3.3. Reactive Heat-Integrated Distillation Column (R-HiDiC). Reactive heat-integrated distillation columns (R-HiDiC) combine the benefits of reactive distillation and internally heat-integrated distillation columns applying vapor recompression and heat integration. The stripping section, operating at a lower pressure, acts as a heat sink. Vapor exiting the stripping section is pressurized with a compressor and then enters the rectifying section that acts as a heat source, schematically represented in Figure 1c. Using different pressures in the column sections could potentially increase the range of operating conditions, compared to RD.²² From a practical point of view, equipment realization is challenging, and the literature about nonreactive HiDiC presents various design alternatives.²² In a configuration that has been successfully applied industrially, SuperHiDiC, heat exchange is realized in a limited number of side heat exchangers, where the stages are not necessarily at the same elevation.²³ In nonreactive HiDiC, the pressure ratio between the stripping and rectifying sections can vary between 1.3 and 3 to avoid a costly compression task.^{22,24} As a rule of thumb, the temperature difference between the lightest and heaviest compounds (ΔT_b) should not exceed 60 °C.²⁵ Thus, the feasibility of R-HiDiC is evaluated using boiling points at different pressures while considering a suitable compression ratio.

3.4. Catalytic Cyclic Distillation (CCD). Catalytic cyclic distillation (CCD) exploits the synergies of combined reaction and separation by manipulating the duration of an event (e.g., residence time) in a cyclic operation. The two-step cycle consists of a vapor-flow period where vapor travels upward while the reaction occurs in the liquid phase and a liquid-flow period where the liquid flows downward from one tray to the next, avoiding remixing (Figure 1d).²⁶ The residence time can be enlarged by manipulating the duration of the vapor flow period. Therefore, CCD is especially suited for systems featuring reactions with an intermediate to slow reaction rate but not too slow that it is better to use a conventional reactor–separator sequence. As a result, CCD may be indicated if the reaction rate is intermediate to slow. Unique internals suited for cyclic operation are not suitable for vacuum operation.²⁷ Technology readiness based on pilot and industrial experience is low.⁴

3.5. Membrane-Assisted Reactive Distillation (MA-RD). A membrane module coupled to an RD column helps overcome thermodynamic limitations by introducing a separation mechanism based on the difference in chemical potential, using partial pressures. Membrane separation methods that can complement separations by distillation are pervaporation or vapor permeation.^{28,29} The membrane module can be located on an inlet stream to selectively remove impurities or prefractionate the mixture or on an outlet stream to break azeotropes or recover homogeneous catalysts, where the latter typically applies nanofiltration (Figure 1e).²⁸ In this methodology, MA-RD is suggested when a problematic azeotrope is present at a similar temperature to those of the components to be separated and obtained as an outlet stream. Operating pressures above atmospheric are preferred for the reactive distillation column because the flow across the membrane is

driven by the pressure drop, so a stream at subatmospheric pressure entering the membrane module may lead to engineering challenges.

4. RESEARCH APPROACH

4.1. Development of the Synthesis Methodology. This work used data and results (e.g., feed and product specifications, types of reactions and kinetic models, type of catalyst, and operating conditions) from reports, patents, and published studies focusing on a specific technology. These studies cover diverse scopes (e.g., technical, economic, and environmental), which were used as a basis for identifying which characteristics favor the use of a particular technology. The secondary research data and results were organized and compared to find commonalities that could aid flowsheet development, where technical feasibility is an essential preliminary checkpoint for further design. High-level questions based on thermodynamic and kinetic parameters were formulated in a conceptual framework.³⁰ In this work, these high-level questions are organized systematically in a decision-making flowchart to identify the characteristics that distinguish the advantages and disadvantages of different ARDT following a knowledge-based approach based on first principles, heuristics, and process intensification principles.³¹

4.2. Scope of the Synthesis Methodology. This work focuses on a subset of the design problem for rapid evaluation of ARDT (i.e., R-DWC, R-HiGee, R-HiDiC, MA-RD, and CCD). The methodology covers equilibrium-limited reactions in the liquid phase, heterogeneously catalyzed, as are typically the case in RD processes.³² Application of the synthesis methodology to homogeneously catalyzed reactions should be done with caution. This is because homogeneous catalysts tend to be more active than heterogeneous catalysts, so different ranges of reaction rates could apply. Additionally, it should be ensured that the homogeneous catalyst is sufficiently available within the liquid phase, and this could be included when evaluating operating windows.

A special case applied to fluid separations is the introduction of a “reactive separation agent” (RSA) (analogous to a mass separation agent used to facilitate separations) that promotes a reversible reaction, where the forward and reverse reactions are needed to achieve the desired separation. With an appropriate RSA, the products from the forward reaction can be easily separated, and the reverse reaction is finally used to recover the original target component. In addition, fast solid-catalyzed reactions of a stripping gas absorbed in the liquid phase could be explored for suitability where rapid removal of reaction products is needed.¹⁷

This general methodology accounts for features relevant to large-scale industrial applications. These features include azeotropes, impurities, multicomponent mixtures, difficult separations, and types of utilities, while laboratory-scale investigations and simulation-based studies often do not consider them.

This methodology is proposed for the early stages of process design when information about the chemical system is often limited. However, complex feeds, such as biomass-derived oils for biodiesel production that have highly variable compositions and are difficult to characterize, are out of scope. While a model compound could be used to represent the feed, results are expected to depend significantly on which model compound is selected as well as availability of data.^{33,34} In addition, complex reaction networks that increase the number of interdependent

interactions cannot be assessed in the methodology, as identified for the production of *iso*-octane where two main reactions (dimerization and hydrogenation) compete with the formation of various oligomers of *iso*-butene,^{35–37} nor does this synthesis approach account for possible miscibility gaps because of the sensitivity to composition and operating conditions. Given the exploratory nature of the proposed methodology, capital costs and opportunities for heat integration are not investigated, being outside the scope. However, efficient use of energy is partially addressed when evaluating operating windows.

4.3. Decision-Making Flowchart. The methodology is organized into four steps that group different aspects of the chemical system assessed: (1) compositions and splits, (2) basic properties and operating windows, (3) kinetics, and (4) phase equilibrium. Each step contains one or more high-level questions denoted as the “starting question” that invites the user to collect information about the chemical system to identify potential interactions and their effects. These “starting questions” were organized systematically, maintaining a balance between the depth and breadth of chemical system features to facilitate analysis and focus on those features that could significantly affect flowsheet development. This is important when realistic features that increase the complexity of the problem are included.

The “decision points” refine the queries posed by the high-level questions to distinguish between interactions that may (or may not) affect the operation. Potential decisions include options for selection of technologies, yes/no answers, or ranges of values. Figure 2 shows the color code used to denote the

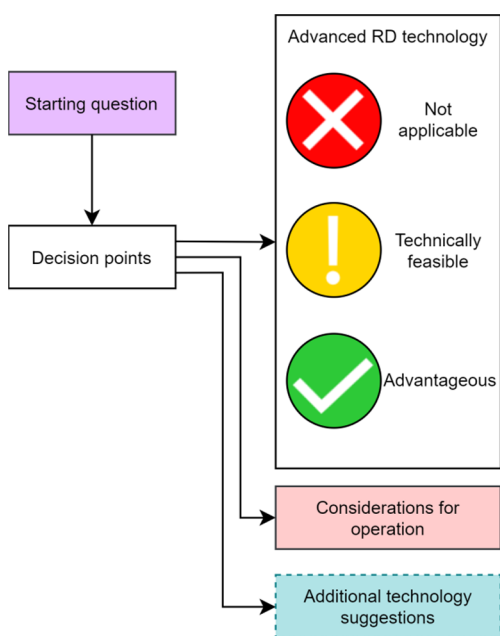

Figure 2. Color code used in the decision-making flowchart.

sequence of actions aiding decision-making and the results of the methodology.

- Options for the selection of technologies are presented with a traffic light system. Green indicates that the technology is advantageous, amber indicates that it is technically feasible with no particular advantage, and red eliminates a technology due to hardware or operating specification limitations. Additional units that could be

explored beyond the scope of the methodology are presented in dashed line blocks. Actions that can be solved within the scope of the methodology when evaluating another starting question are presented with a solid line block.

- Yes/no answers can lead to another decision point, a range of values, or a particular technology. In some cases, both yes and no answers may be valid, for example, when a feasible range of operating pressures spans both above and below atmospheric pressure. In these cases, two different paths may be followed in the flowchart.
- Ranges of values are used for reference only and do not represent a hard limit. These values can fluctuate depending on the system and operating conditions, so more than one option can be selected.

4.3.1. Step 1: Compositions and Splits. Identifying components and compositions, particularly for the feed and main product, is essential to define the design problem. Components can include reactants, products, byproducts, catalysts, and impurities.

- Reactants and products are target components of the operation as they are involved in the main reaction.
- Byproducts result from parallel or series reactions, which are usually undesired because they consume valuable raw materials and complicate downstream processing.
- Impurities accompanying the main reactants are evaluated based on their quantity and their chemical interactions (whether reactive or inert) to identify potential effects on process performance. Reactive impurities could add or remove energy due to heat of reaction, and inert impurities in large amounts increase the material recycle in the system. This evaluation is important as, from the beginning, it is possible to identify potential increase in costs due to changes in energy use and large equipment.^{38,39}

A special case for a feed is when it is an intermediate process stream that contains a large number of components. Listing all the impurities and choosing only those representing a light inert, heavy inert, or potentially reactive compound can help characterize their impact while facilitating analysis. Different scenarios can be established (stoichiometric vs excess reactant, partial vs complete conversion, series reactions, and byproduct formation) to identify potential impacts. Figure 3 presents the decision-making flowchart to evaluate compositions and splits.

4.3.1.1. Inlet Stream Composition. The feed stream composition considers (1) the main reactant and (2) “other components” that are in large quantities or that may interact with critical reactants or solid catalysts. Relevant interactions may arise when an inert component is present in significant amounts, when a reactive component induces side reactions, or when a component can deactivate a solid catalyst. The decision-making procedure uses these interactions to suggest actions or other decision stages in the methodology. An explanation of these actions is provided hereafter:

- Inert: These could be removed in a preconcentration stage when present in large amounts. However, inert compound concentrations can sometimes be adjusted to favor conversion, selectivity, and yield. For example, on the one hand, more inert material is advantageous to achieve a dilution effect that suppresses reaction rates and dampens the effect of the heat of reaction. Conversely, a lower inert concentration can reduce byproduct for-

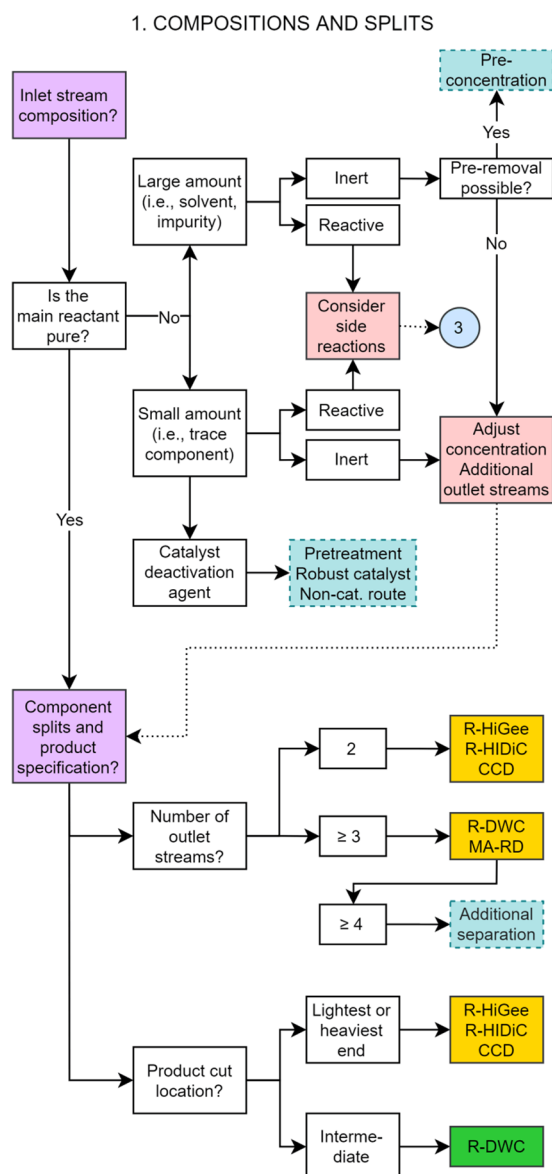

Figure 3. Step one: composition and split flowchart.

mation by shifting the equilibrium away from the undesired byproduct from side reactions.^{38,39} Finally, inert compounds need to be considered when defining the output streams for their removal.

- **Reactive:** The component promotes side reactions that can impact yield, selectivity, and operating costs. Side reactions are considered when evaluating kinetics.
- **Catalyst deactivation agent:** Whether the deactivation is temporary or permanent, the feed could be pretreated in a guard bed. If the deactivation is permanent, noncatalytic routes or more robust catalysts may need to be explored.

4.3.1.2. Splits and Product Specifications. Splits and product specifications are used to determine the number of outlet streams and the location of the product stream. A split refers to the action of separating the components of a mixture into two products, which could be either pure or a mixture.⁴⁰ Depending on the component distribution, a split can be sharp (each component appears only in one product) or nonsharp (each component appears in both products).⁴⁰ Two criteria are

used to define splits: the nature of the component and the boiling point order.

The nature of the component refers to the role of each component in the reaction–separation system following the definition provided in our work about operating windows:⁵ reactants, products, intermediate products, byproducts, or impurities (which could be reactive or inert). Then, boiling points at a specified pressure (e.g., atmospheric) allow the components to be arranged from the lightest to the heaviest. If the operating pressure is likely to differ significantly from atmospheric, the boiling point order may need to be revisited. At this point, azeotropes are not considered because they are analyzed in the phase equilibrium step.

If an intermediate boiling component is to be removed, two splits around the component are necessary to ensure the

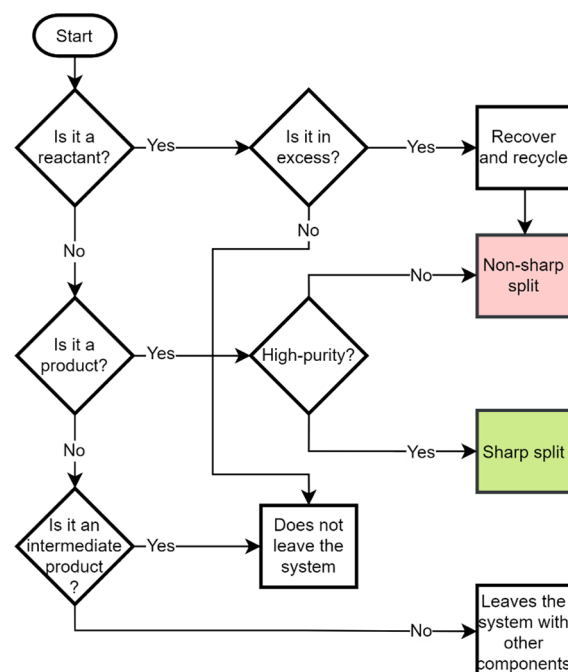

Figure 4. Flowchart to identify splits.

required specification. Figure 4 and the following guidelines help to identify the splits (number of streams).

- Reactants in excess need to be recovered and recycled. A nonsharp split suffices as long as there is no substantial recycling of components that can build up in the system. Incomplete conversion due to the equilibrium limitations could also be considered.
- To meet the product specifications, when high purity is required, one should aim for a sharp split; otherwise, a nonsharp split may suffice. Determining the type of split can guide the definition of operating parameters or design specifications when performing a detailed design, in a later stage.
- Limiting reactants and intermediate products remain inside the ARDT device.
- Byproducts and impurities could be removed together.

Two product streams are easily managed in R-HiGee, R-HIDiC, and CCD, whereas an R-DWC or MA-RD allows withdrawal of three product streams. If the system has four

more streams, additional separation may be needed to achieve all the splits.

Finally, the location of the product cut can influence the selection of technologies because the withdrawal of a concentrated stream of the middle-boiling component in an R-DWC avoids remixing effects and results in higher purities compared to a conventional RD.¹⁴

4.3.2. Step 2: Basic Properties and Operating Windows. Two data sets required for the second step include saturation temperatures at different pressures and materials and experimental method constraints. These data are used to evaluate ARDT, as detailed in a previous study that introduces the concept of “representative components” and the use of “sliding windows” to add flexibility to the boundaries of the operating window.⁵ Among the “representative components”, the lightest and heaviest are the light representative and the heavy representative components; these define boundaries to the operating window. Also, the reaction rate constant (discussed in detail in Step 3) is included when building the operating window to identify temperature limits that might help prevent undesired side reactions.

The main findings of the operating windows are the operation boundaries for pressure and temperature and the definition of the temperature difference between the light and heavy representative components (ΔT_b) as a characteristic value for the chemical system (Figure 5). Results guiding the selection of technologies are based on the operating pressure and ΔT_b .

Operation below atmospheric pressure is not possible for R-HiDiC and CCD because of hardware limitations. For MA-RD, operation at or above atmospheric pressure is preferred because a stream at subatmospheric pressure may lead to engineering challenges for membrane operation. Regarding ΔT_b , heuristics from applications in nonreactive distillation technologies are used to provide reference values to navigate the decision-making flowchart. When ΔT_b is lower than 60 °C, vapor recompression and internal heat integration could prove advantageous for close boiling component systems because economic compression costs could be achieved.²² When ΔT_b varies between 60 and 150 °C, MA-RD, CCD, R-HiGee, and R-DWC could potentially cover the range of temperatures required. However, when ΔT_b is larger than 150 °C and a relatively large amount of light components is present (~25%), an additional separation unit at different pressures may be needed to avoid incurring excessive costs due to a refrigerated condenser.⁴¹

4.3.3. Step 3: Kinetics. The kinetic parameters, i.e., the pre-exponential factor and activation energy, are used to determine the forward reaction rate constant of the main and relevant side reactions (Figure 6).

4.3.3.1. Forward Reaction Rate Constant at the Reaction Temperature. Evaluating reaction rates is challenging due to factors influencing their values (e.g., initial concentrations, type of catalyst, solvents used, kinetic experiments, and regression models). Using absolute reaction rates does not allow performing a fair comparison between different chemical systems because reaction rates depend on concentrations (e.g., molar concentration, mole fraction, and activities), order of the reaction, and the basis used, such as the reaction volume or mass of the catalyst. Therefore, the reaction rate constant expressed in SI units (kmol, kg, and s) is used as a reference to classify reactions as relatively slow, intermediate, or fast. The cutoff values were defined after a survey of previous works performed on RD⁴² and ARDT to establish a range of reaction rates. Chemical systems tested in R-HiGee provided reference values

2. BASIC PROPERTIES AND OPERATING WINDOWS

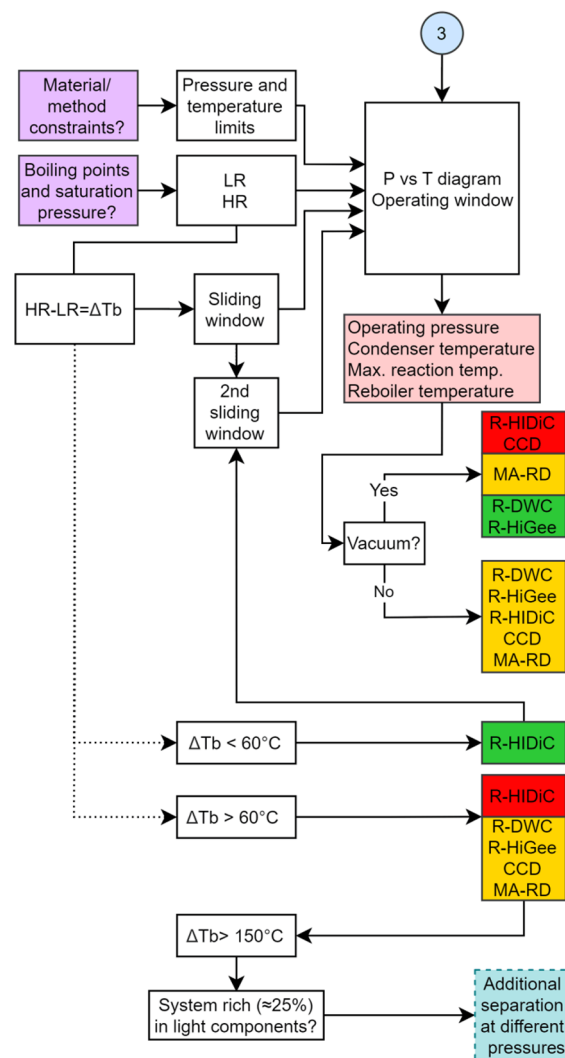

Figure 5. Step two: basic property and operating window flowchart.

for relatively fast reactions,^{43,44} while chemical systems tested in CCD provided reference values for relatively slow reactions.⁴⁵ Initially, the reaction rate constant of the main reaction is evaluated at a given reaction temperature or at a reference temperature (e.g., a temperature that enhances the main reaction, maximum reaction temperature).

Fast reaction rates can take advantage of the short residence times in R-HiGee enabling quick product removal,^{19,43} while slow reactions are suited to CCD where the duration of the vapor flow period, when the reactions take place in the liquid phase, can be extended.^{46,47}

4.3.3.2. Side Reactions. Side reactions can occur in parallel or in series. Impurities, which normally accompany the main reactant in the feed stream, can promote parallel reactions when reactive. Series reactions depend on the chemical stability of the reaction products and can consume valuable products from the main reaction. Some parallel reactions can be avoided by adjusting the composition of the liquid phase. This modification is possible by locating feed and draw streams appropriately, taking advantage of the features of an R-DWC. For example, byproduct formation can be inhibited through recycling some byproduct or allowing buildup in the system, hence shifting the equilibrium.³⁹ Some series reactions can be prevented by rapid

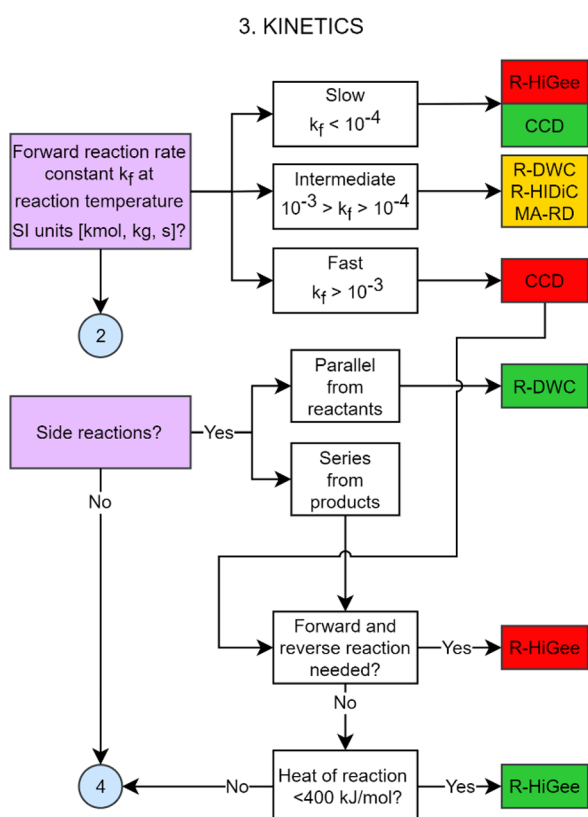

Figure 6. Step three: kinetic flowchart.

removal of reaction products, such as in an R-HiGee. However, the poor heat transfer in R-HiGee may not allow high heats of reaction to be accommodated.⁴⁸

A special application of RD for fluid separations is when a “reactive separating agent” is introduced to promote an equilibrium-limited reaction, where the products of the forward reaction are easy to separate; the reverse reaction can then be promoted to recover the component of interest.⁵ Such a dual reactive separation system can be engineered to provide sufficient residence time taking into account the volume occupied by the catalyst. R-HiGee is unlikely suited to the use of reactive separation agents due to its short residence times.

4.3.4. Step 4: Phase Equilibrium. Especially in systems with nonideal liquid-phase behavior, separations may be difficult (e.g., azeotropes may form). Data about azeotropes that form can provide insights into the thermodynamic constraints of a given system. RD technologies offer advantages in such nonideal systems, compared to a conventional reaction–separation flowsheet, because azeotropes can be “reacted away”, facilitating required separations.²

This work compares data about azeotrope temperatures to boiling temperatures of the pure components, all arranged in the order of increasing boiling point at a reference pressure (i.e., atmospheric). If the required split, identified in Step 1, is away from the azeotrope, it is likely that the azeotrope could be reacted away if the reactive zone is located around the azeotrope temperature, hence facilitating separation. If the desired split is close to the azeotrope temperature, it is likely that the output stream contains the azeotrope, which would require additional techniques to break the azeotrope. In these cases, the azeotrope could be separated by using a different driving force. For example, MA-RD could be used, if a suitable membrane is

available. The flowchart in Figure 7 helps to identify azeotropes that can undermine the purity of the products; hence, they need to be treated further.

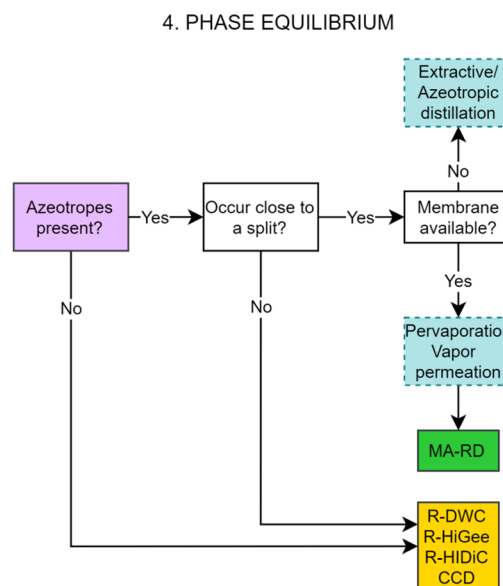

Figure 7. Step four: phase equilibrium flowchart.

In this work, systems with two or more liquid phases are not taken into account, given the sensitivity of liquid-phase splitting to composition and operating conditions. Distillation regions and reactive azeotropes are not considered despite their relevance.⁹ This is because more detailed information regarding azeotrope compositions and their variation with operating conditions and experimental data or methods to identify reactive azeotropes are limited. A deeper examination of these characteristics is recommended after initial screening has revealed potential advantages and shortcomings.

4.4. Selection of Advanced Reactive Distillation Technologies. The results of the steps in the synthesis methodology are summarized in a decision-making matrix to facilitate analysis collating all aspects in a single view. This allows a quick evaluation, categorizing the methodology outcomes qualitatively as advantageous, technically feasible, or not applicable. Decision points aiding the selection of technologies are listed horizontally (e.g., the number of outlet streams, product cut location, vacuum operation, ΔT_b , reaction rate constant, side reactions, and azeotropes), while ARDT options are listed vertically.

The applicability of each technology is indicated using a traffic light system according to the properties of the chemical system of interest and allows justifying important conditions to support the selection of technologies (Figure 2). Those technologies that have only green and amber indicators are identified as potentially advantageous, while those with mainly amber indicators are identified as technically feasible. Technologies with mainly red indicators are deemed to be not applicable. In the case that two technologies are deemed equally advantageous, they could be ranked by assigning a weight to each color (e.g., green = 2, amber = 1), where the highest ranked are candidates for further investigation. Due to the qualitative nature of the approach, the results are not conclusive, but they provide a basis for further evaluation that is supported with a sound theoretical basis (thermodynamic properties and kinetic parameters) and

heuristics as opposed to other more rigorous approaches, which are generally more complex and time-consuming.⁴⁹ A conservative approach would have more stringent criteria, e.g., all indicators must be green, while a less conservative approach could shortlist both “advantageous” and “technical feasible” technologies. Additional technologies that could complement ARDT operation are suggested in dashed-lined boxes, which are indicated in an additional column in the decision-making matrix.

5. CASE STUDIES TO DEMONSTRATE THE APPLICATION OF THE SYNTHESIS METHODOLOGY

The synthesis methodology is applied to five case studies, aiming to identify suitable ARDT using basic thermodynamic properties and kinetic parameters. The results are compared to flowsheets studied quantitatively in the literature, in order to check whether the outcomes of the methodology, using only basic information, are potentially realizable. Background information required to answer high-level questions is provided in the [Supporting Information](#) for each case study. The outcomes of the methodology are summarized in the decision-making matrix, which are illustrated in a process flow diagram (PFD) showing a potential configuration and the range of operating conditions (obtained from the operating windows).

5.1. Purification of Lactic Acid. *5.1.1. Description of the Process and the Design Problem.* Production of lactic acid has drawn the attention of academia and industry due to its applications in the food industry, pharmaceuticals, personal care, and biodegradable polymers (e.g., polylactic acid) and as a building block molecule, where lactic acid is produced by fermentation of sugars.⁵⁰ This case study focuses on purification of lactic acid from a mixture containing reactive succinic acid and water as a solvent.

The required separation is difficult; in this work, a reactive separating agent—methanol—facilitates the separation by promoting esterification of lactic acid and succinic acid, where the products (methyl lactate and dimethyl succinate) can be separated by distillation. Once the heavy succinates are removed, the reverse reaction—hydrolysis—uses water to convert methyl lactate into lactic acid, now free from the impurity. Problem data are provided in the [Supporting Information](#) in [Table S1](#) and [eqs S1–S5](#).

5.1.2. Methodology Application and Outcomes. The feed consists of lactic acid, substantial amounts of water, and succinic acid as a reactive impurity ([Table S2](#) in the [Supporting Information](#)).

- Step 1: Water is inert; it acts as a solvent and can be partially removed. The remaining water must be removed to meet product specifications while adjusting the composition of the liquid phase to promote hydrolysis to obtain lactic acid back after the impurity has been removed. Succinic acid is prone to side reactions and needs to be considered because it is a reactive impurity. [Table 1](#) lists the components in the order of increasing boiling point, their nature, and the desired splits: methanol is recycled; water is removed in preconcentration and downstream steps; byproducts and unreacted succinic acid are removed before hydrolysis, where methyl lactate is the dominant species; lactic acid is recovered after hydrolysis. The flowchart identifies R-DWC and MA-RD as potentially attractive candidates, but additional separation units would be needed to obtain the

Table 1. List of Components, Nature, and Splits for the Lactic Acid System

component	nature	NBP (°C)	output stream ^a
methanol (LR)	reactant	64.5	8
water	reactive impurity/intermediate product	100.0	2, 9
methyl lactate	intermediate product	144.8	-
dimethyl succinate	byproduct	196.4	7
dilactic acid	byproduct	215.9	7
lactic acid (HR)	reactant/product	216.6	6
monomethyl succinate	byproduct	222.6	7
succinic acid	reactive impurity	317.6	7
trilactic acid	byproduct	345.9	7

^aStream numbers correspond to the flowsheet in [Figure 8](#).

required product streams. R-DWC enables removal of intermediate-boiling lactic acid as a side stream.

- Step 2: Methanol and lactic acid are identified as the light and heavy representative components, respectively.⁵ The suggested operating pressure ranges from 0.35 and 0.83 atm to avoid degradation of succinic acid. Technologies suitable for vacuum operation are R-DWC and R-HiGee, while MA-RD presents challenges. R-HiDiC and CCD are not applicable for vacuum operation. The ΔT_b is about 152 °C at atmospheric pressure. Therefore, R-DWC, R-HiGee, CCD, or MA-RD would need additional separation units.
- Step 3: Methyl lactate production (main reaction) has an intermediate-to-fast reaction rate, while the reaction producing succinates (byproducts) is slower. Hence, the intermediate and fast ranges are selected. The side reaction between methanol and succinic acid occurs in parallel, which consumes the reactive separating agent. To suppress the esterification of succinic acid, side draws in an R-DWC can be advantageous to modify the composition of the liquid phase in a given stage, hence modifying the driving forces for the reaction. The oligomerization of lactic acid occurs in series, where R-HiGee could potentially hinder this reaction. However, in the special case where the forward and reverse reactions are required, R-HiGee may not be able to provide enough residence time.
- Step 4: The system contains five homogeneous azeotropes ([Table S3](#) in the [Supporting Information](#)). Azeotropes between lactic acid and succinates are potentially problematic. However, succinates are produced in parallel with methyl lactate, and the heavier succinates can be removed before hydrolysis. Then, lactic acid is produced in the absence of succinates. Azeotropes that are away from the splits can be consumed within the reactive section of R-DWC, R-HiGee, CCD, and R-HiDiC. [Figure S1](#) in the [Supporting Information](#) illustrates the application of the flowchart; the outcomes are summarized in the matrix presented in [Table 2](#).

The flow diagram in [Figure 8](#)—an R-DWC with auxiliary units—is proposed, based on the above findings. The method identifies the range of operating conditions: maximum temperature in the reactive section of 150 °C, operating pressures between 0.35 and 0.83 atm, a condenser temperature between

Table 2. Decision-Making Matrix for the Lactic Acid System

Criteria	Number of outlet streams	Product cut location	Vacuum operation	ΔT_b	Reaction rate constant	Side reactions	Azeotropes	ARDT selection from the synthesis methodology	Additional technology ^a
R-DWC	ⓘ	Ⓢ	Ⓢ	ⓘ	ⓘ	Ⓢ	ⓘ	Advantageous	i, iii, iv
R-HiGee			Ⓢ	ⓘ	ⓧ	ⓧ	ⓘ	Not applicable	i, iii
R-HIDiC			ⓧ	ⓧ	ⓘ		ⓘ	Not applicable	i, iii
CCD			ⓧ	ⓘ	ⓧ		ⓘ	Not applicable	i, iv
MA-RD	ⓘ		ⓘ	ⓘ	ⓘ			Feasible	i, iii, iv

^a(i) Preconcentration, (ii) catalyst safeguarding technologies, (iii) additional separation for extra streams, (iv) additional separation at different pressures, (v) azeotrope-oriented technologies, and (vi) membrane module.

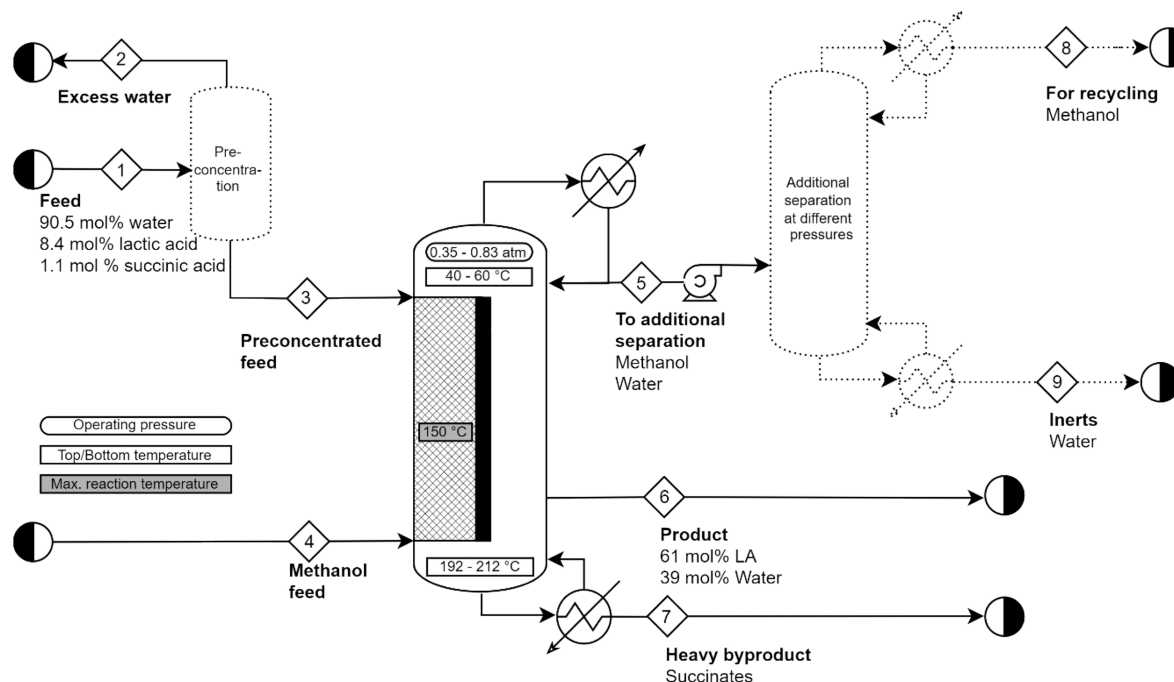

Figure 8. PFD for the lactic acid system including additional equipment (indicated with dotted lines).

40 and 60 °C, and a reboiler temperature between 192 and 212 °C.⁵

R-DWC is deemed potentially advantageous: the side draw provides the main product, operation is under vacuum, and undesired parallel reactions are hindered. The need for additional separation units is identified, to meet product specifications and to remove impurities and water. These preliminary results clearly identify the ARDT with the best potential to satisfy the design problem among the technologies studied because the synthesis methodology was able to eliminate those potentially unfeasible from the evaluation.

5.1.3. Comparison of the Results of the Methodology with the Literature. The advantages of R-DWC agree with those observed in earlier studies. For example, simulation studies found that R-DWC and thermally coupled arrangements are advantageous in terms of energy use when compared to conventional RD.^{51,52} In addition, our previous conceptual design study helped identify the benefits of a dual R-DWC by using detailed kinetics for the main and side reactions in a rigorous simulation. The configuration improved energy use, material intensity, and water consumption.⁵³ MA-RD could be used but with no specific advantage, except for the case where an azeotrope needs to be dealt with and if a suitable membrane exists.

R-HiGee, CCD, and R-HIDiC are discarded. Gudena et al.⁵⁴ evaluated methyl lactate hydrolysis in an R-HiGee stripper-membrane process, so this study is used to verify the outcomes of the methodology. The hydrolysis of methyl lactate, which is needed to recover lactic acid after impurity removal, is slower than the esterification of lactic acid. Gudena et al.⁵⁴ concluded that a relatively longer residence time is necessary to achieve a higher conversion for the substrate. In addition, a decrease in feed conversion and a marginal increase in operating cost were observed compared to a conventional reactive stripper coupled to a membrane. When evaluating kinetics in the proposed synthesis methodology, both the forward and reverse reactions were considered, which allowed identifying R-HiGee as unsuitable for a special case when both reactions are needed. Finally, the main limitation for applying R-HIDiC and CCD depends on the inability to operate in a vacuum.

5.2. Production of Dimethyl Ether (DME). **5.2.1. Description of the Process and the Design Problem.** DME is typically produced in a catalytic fixed-bed reactor at a high pressure. Table S4 in the Supporting Information provides an overview of the DME system. The feed consists of pure methanol, which is dehydrated to produce DME and water (eq S6 in the Supporting Information). Numerical values used as inputs for the

application of the methodology are provided in Table S5 in the Supporting Information.

5.2.2. Methodology Application and Outcomes.

- Step 1: The feed is pure methanol, so no interactions are expected apart from the main reaction to obtain DME (eq S6 in the Supporting Information). Two outlet streams are expected since full conversion of methanol is assumed, and DME is the lightest compound that could be recovered from the top of the column. The list of components in the order of increasing boiling point and their nature are provided in Table 3.

Table 3. List of Components, Nature, and Splits for the DME System

components	nature	NBP (°C)	output stream ^a
dimethyl ether (LR)	product	-24.8	2
methanol	reactant	64.7	-
water (HR)	byproduct	100.0	3

^aStream numbers correspond to the flowsheet in Figure 9.

- Step 2: DME and water are the light and heavy representative components, and their vapor pressure curves provide boundaries for the operating window.⁵ Relatively high operating pressures (8.8 to 14.3 atm) are required because of the high volatility of DME. Therefore, all ARDT are suited for operation above atmospheric pressure. The ΔT_b is 125 °C at atmospheric pressure, so R-DWC, R-HiGee, CCD, and MA-RD could operate without further separation.
- Step 3: The reaction rate constant at 90 °C indicates that the reaction is relatively slow, suggesting CCD due to larger residence times, thus ruling out R-HiGee. The system does not present side reactions.
- Step 4: The system does not present azeotropes; hence, there is no restriction for R-DWC, R-HiGee, CCD, or R-HiDiC. The ternary diagram showed an envelope where two liquid phases coexist,⁵⁵ when the mixture is lean in methanol, which is unlikely. However, the effect of this miscibility gap could be further explored in a more detailed study.

The decision-making flowchart is shown in Figure S2 in the Supporting Information. The decision-making matrix in Table 4 indicates that CCD could be advantageous for the production of DME due to the relatively slow reaction rate, while R-DWC and MA-RD are technically feasible. R-HiGee and R-HiDiC are discarded.

Table 4. Decision-Making Matrix for the DME System

Criteria	Number of outlet streams	Product cut location	Vacuum operation	ΔT_b	Reaction rate constant	Side reactions	Azeotropes	ARDT selection from the synthesis methodology	Additional technology ^a
R-DWC			⚠	⚠		-	⚠	Feasible	-
R-HiGee	⚠	⚠	⚠	⚠	✖	-	⚠	Not applicable	-
R-HiDiC	⚠	⚠	⚠	✖		-	⚠	Not applicable	-
CCD	⚠	⚠	⚠	⚠	✔	-	⚠	Advantageous	-
MA-RD			⚠	⚠		-		Feasible	-

^a(i) Preconcentration, (ii) catalyst safeguarding technologies, (iii) additional separation for extra streams, (iv) additional separation at different pressures, (v) azeotrope-oriented technologies, and (vi) membrane module.

Figure 9 presents a potential configuration for the production of DME, including the operating conditions found from the

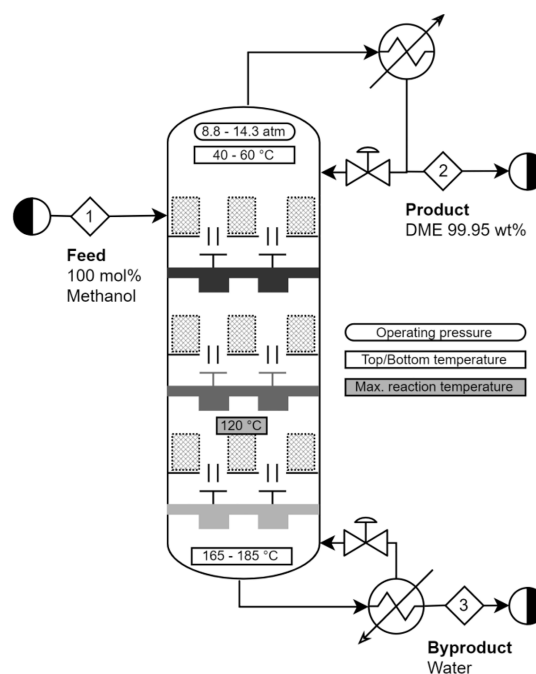

Figure 9. PFD for the DME system.

operating window. The maximum temperature in the reactive section is 150 °C, and the top and bottom temperatures are 40–60 and 165–185 °C, respectively. The range of operating pressures is 8.8 to 14.4 atm.

This case study is relatively straightforward to analyze due to the small number of components involved, no side reactions, and no azeotropes. Although the decision-making matrix shows feasibility for all ARDT in most decision points, the rate of reactions is decisive in identifying CCD as advantageous and discarding R-HiGee. R-HiDiC is also discarded as the temperature ranges may incur high compression costs.

Taken together, these results suggest that CCD is advantageous based on the reaction rate criterion, but R-DWC and MA-RD are technically feasible based on other characteristics. This case study raises the possibility of various process alternatives being suitable if the answers to decision points change. For example, an accelerated reaction with a different catalyst, partial conversion where unreacted methanol needs to be recovered, and the miscibility gap are already identified but not considered in the analysis.

5.2.3. Comparison of the Results of the Methodology with the Literature. In accordance with these results, previous studies have shown that different technologies could successfully produce DME depending on aspects not included in the context of the proposed synthesis methodology (e.g., retrofit vs new design), allowing alternative processing options depending on the context. For example, Bildea et al.⁴⁷ found RD to be particularly useful for revamping existing plants.

Conceptual design studies for the production of dialkyl ethers, including DME, indicated that, compared to conventional RD, CCD could achieve higher product purities while reducing the number of stages and the vapor flow rate.^{26,56} Rasmussen et al.⁵⁷ analyzed the production of DME using quantitative metrics to evaluate the performance of CCD, including the mean Damköhler number, which accounts for characteristics of the technology.

Conceptual design studies corroborate the feasibility of R-DWC.^{58,59} Kiss and Suszwalak⁵⁸ proposed an R-DWC operating at 10 bar that showed energy savings compared with conventional RD. Gor et al.⁵⁹ found that RD presents 10.68% less total annualized costs (TAC) than an R-DWC operating at 9 to 10 bar with two reactive sections, one at each side of the wall. This apparent discrepancy may be explained by the scope of the analysis, where Kiss and Suszwalak⁵⁸ use energy use (i.e., operating costs) as an indicator, whereas Gor et al.⁵⁹ included capital costs. In addition, both RD and R-DWC performed better than conventional configurations.⁵⁹ A compromise between the integration of functionalities and the ease of implementation is still being evaluated for RD, which depends heavily on the type of catalyst used and hence on the reaction kinetics.^{47,59}

Regarding MA-RD, a pervaporation-assisted RD configuration presented promising results in terms of TAC compared to a conventional RD column.⁶⁰ In summary, the proposed synthesis methodology suggests technologies that are worth exploring further, denoting aspects that could be adjusted to overcome a limitation, such as catalyst robustness. For example, Su et al.⁶¹ proposed a dual R-DWC that uses two reaction zones with catalysts that withstand different temperatures to enlarge the catalyst life.

5.3. Production of *tert*-Amyl Methyl Ether (TAME).

5.3.1. Description of the Conventional Process. TAME is a fuel additive produced from the addition of isoamylenes to methanol. The FCC unit in an oil refinery provides the feed stream that contains inert alkanes, olefins, cyclic components, and sulfur. In the Supporting Information, Table S6 presents an overview of the TAME system, while Table S7 provides numerical values applied in the methodology, and the reactions involved are presented in eqs S7–S12.

5.3.2. Methodology Application. The design problem involves the transformation of isoamylenes into TAME while dealing with large amounts of inert materials, potential side reactions, and unwanted byproducts.⁶² The main reactions are TAME formation from isoamylenes 2M1B and 2M2B and one isomerization reaction between 2M1B and 2M2B, which are equilibrium-limited.⁴² Possible side reactions include the formation of dimers and trimers of 2M1B and 2M2B⁶³ and methanol condensation to DME.⁶⁴ All reactions are given in eqs S7–S12 in the Supporting Information. Most simulation studies omit side reactions in their models, but investigating the effect of side reactions is necessary because they can affect operation. Therefore, two scenarios are evaluated to apply the synthesis methodology: Scenario 1 considers the main reactions only (eqs

S7–S9), and Scenario 2 accounts for side reactions also (eqs S7–S12).

Table 5. List of Components, Nature, and Splits for the TAME System (Scenario 1)

components	nature	NBP (°C)	output stream ^a
isopentane (LR)	inert impurity	27.8	3
1-pentene	inert impurity	30.1	3
2M1B	reactant	31.2	-
2M2B	reactant	38.6	-
cyclopentane	inert impurity	49.3	3
methanol	reactant	64.7	4 ^b
TAME (HR)	product	86.4	5

^aStream numbers correspond to the flowsheet in Figure 10. ^bWhen methanol is fed in excess.

5.3.2.1. Scenario 1: TAME Production Disregarding Side Reactions.

- Step 1: Table 5 lists the components in the order of increasing boiling point, their nature, and notes the light and heavy representative components. Preremoval of inert materials is difficult due to their close boiling points, so the expected outlet streams include impurity removal.
- Step 2: The ΔT_b is 60 °C, which indicates that an R-HiDiC could provide advantages. Our previous publication about operating windows⁵ found the operating pressure to be between 0.11 and 4.4 atm for the stripping section and between 1 and 13.2 atm for the rectifying section. Although the range of pressures found for the stripping section covers values below and above atmospheric, only pressures above atmospheric are considered here as they account for the largest range of operating conditions.
- Step 3: The reaction rate constant at 90 °C has a magnitude of 10^{-3} , which allows the application of R-HiDiC, R-DWC, and MA-RD.
- Step 4: Scenario 1 features seven azeotropes detailed in Table S8 in the Supporting Information. Most azeotropes occur with methanol, and of particular interest is the low-boiling azeotrope formed between methanol and TAME. This azeotrope is problematic because it occurs next to a desired split so that a membrane module could be used in an MA-RD column. Several studies applying pervaporation to deal with the methanol-TAME azeotrope have been investigated.^{65–67}

5.3.2.2. Scenario 2: TAME Production Considering Side Reactions. Scenario 2 considers series reactions producing dimers and trimers and methanol condensation producing DME and water. A characteristic dimer is 2,3,4,4-tetramethyl-1-hexene, which promotes the production of 2,4,6,6,7,7-hexamethylnon-3-ene (characteristic trimer). The components in Scenario 2 are shown in Table 6.

- Step 1: Extra outlet streams are needed due to the additional byproducts. R-DWC or MA-RD allows at least three outlet streams. Because of heavy byproducts, the product stream is an intermediate cut, the removal of which is facilitated in an R-DWC.
- Step 2: The light and heavy representative components identified are isopentane and TAME. Due to the large activation energy, the reactions producing DME and oligomers are likely to be slower than the main reactions.

Table 6. List of Components, Nature, and Splits for the TAME System (Scenario 2)

components	nature	NBP (°C)	output stream ^a
DME	byproduct	-24.8	7 ^b
isopentane (LR)	inert impurity	27.8	6
1-pentene	inert impurity	30.1	6
2M1B	reactant	31.2	-
2M2B	reactant	38.6	-
cyclopentane	inert impurity	49.3	6
methanol	reactant	64.7	8 ^b
TAME (HR)	product	86.4	9
water	byproduct	100.0	4 ^b
dimer	byproduct	155.2	4
trimer	byproduct	256.8	4

^aStream numbers correspond to the flowsheet in Figure 11. ^bWhen methanol is fed in excess.

ΔT_b is about 60 °C, which could find advantages in the application of R-HiDiC.

- Step 3: The reaction rate constant is in the intermediate range, so R-HiDiC, R-DWC, and MA-RD are recommended. Oligomerization reactions occur in series and are slower than the etherification reaction, so reducing the contact time will reduce the likelihood of producing dimers and trimers in an R-HiGee. Conversely, dehydration of methanol occurs in parallel, and using R-DWC could be advantageous.
- Step 4: Additional byproducts result in additional azeotropes. Scenario 2 features 17 azeotropes mainly formed with either methanol or water (Table S9 in the Supporting Information). Four homogeneous azeotropes and 13 heterogeneous azeotropes have two or three components. A membrane, in an MA-RD, could deal with the azeotropes between TAME and methanol and between TAME and water that are located near the split to recover the main product.

5.3.3. Methodology Outcomes. The decision-making flowchart for Scenario 1 is illustrated in Figure S3 in the Supporting Information, and the results are summarized in the decision-making matrix in Table 7. R-HiDiC and MA-RD show benefits for the system. Particularly, R-HiDiC is able to exploit the small ΔT_b .

First, Figure 10a presents a potential flowsheet of an R-HiDiC, including a membrane module to deal with the methanol-TAME azeotrope in case of excess methanol. The low-pressure section—stripping section—could operate between 0.11 and 4.4 atm, and the high-pressure section operates between 1 and 13.2 atm. The maximum reaction temperature is

150 °C. The range of temperatures in both sections overlaps, which could initially suggest that heat transfer is not possible. However, temperature profiles depend on the selected operating pressure and the pressure ratio. Second, Figure 10b proposes a potential flowsheet including an MA-RD with operating conditions evaluated in a single operating window, where the operating pressure ranges between 1.5 and 7.3 atm. In both flowsheets, the dotted lines for the membrane module and the methanol stream indicate that they occur when excess methanol is fed.

When considering side reactions in Scenario 2, additional species emerge. The application in the decision-making flowchart is illustrated in Figure S4 in the Supporting Information. The outcomes of the methodology are summarized in the decision-making matrix in Table 8.

Side reactions (both in series and in parallel) and heavy byproducts make the R-DWC appear as the most advantageous technology followed by MA-RD, R-HiDiC, and R-HiGee. Product location and parallel reactions are the main drivers for the use of R-DWC. Due to the additional streams that need to be removed and the problematic azeotropes around the product stream, an additional separation unit and a membrane module are suggested as auxiliary units, illustrated in Figure 11. Potential operating conditions are pressure between 2.7 and 10.9 atm, with a condenser temperature between 60 to 121 °C and a reboiler temperature between 119 and 180 °C. The reaction window is reduced since temperatures between 110 and 150 °C favor main reactions over side reactions.⁵ By analyzing the lightest components in the system, DME and isopentane could be easily separated in a flash vessel due to the large temperature difference between them and the absence of azeotropes. At the heaviest end of the mixture, separation is more challenging due to a heterogeneous azeotrope between TAME and water.

DME production, hence water, occurs at high methanol-to-feed ratios and high temperatures.^{68,69} Therefore, operating close to the stoichiometric ratio could help to avoid producing DME and water (marked with an asterisk in Figure 11). If methanol remains in the system, it will need to be recovered and recycled with additional units (denoted with dotted lines).

This case study was designed to identify the effect of side reactions on technology selection. First, byproducts require to be removed; hence, the number of streams and the location of the product cut change. Second, the decision point accounting for side reactions suggests technologies that could be advantageous to overcome the challenges in Scenario 2.

5.3.4. Comparison of the Results of the Methodology with the Literature. R-HiDiC and MA-RD are advantageous in both scenarios. Although there is no apparent winner for Scenario 1, R-DWC provides additional features that allow overcoming

Table 7. Decision-Making Matrix for the TAME System (Scenario 1)

Criteria	Number of outlet streams	Product cut location	Vacuum operation	ΔT_b	Reaction rate constant	Side reactions	Azeotropes	ARDT selection from the synthesis methodology	Additional technology ^a
R-DWC	(i)		(i)		(i)	-		Feasible	vi
R-HiGee		(i)	(i)			-		Feasible	vi
R-HiDiC		(i)	(i)	(v)	(i)	-		Advantageous	vi
CCD		(i)	(i)			-		Feasible	vi
MA-RD	(i)		(i)		(i)		(v)	Advantageous	

^a(i) Preconcentration, (ii) catalyst safeguarding technologies, (iii) additional separation for extra streams, (iv) additional separation at different pressures, (v) azeotrope-oriented technologies, and (vi) membrane module.

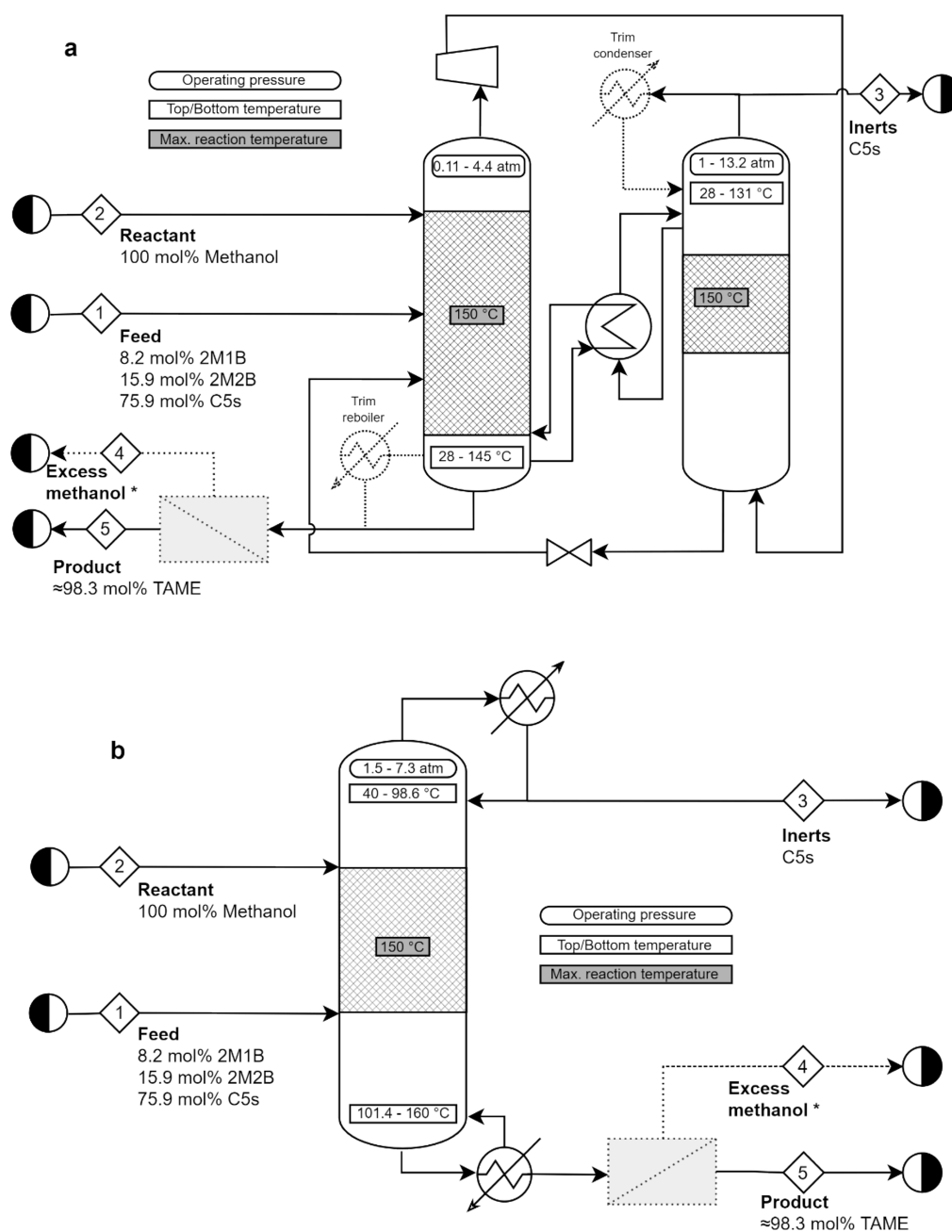

Figure 10. PFD for the TAME system (scenario 1) for an R-HIDiC configuration including a membrane module (a) and MA-RD (b) (*when excess methanol is fed to the system).

Table 8. Decision-Making Matrix for the TAME System (Scenario 2)^a

Criteria	Number of outlet streams	Product cut location	Vacuum operation	ΔT_b	Reaction rate constant	Side reactions	Azeotropes	ARDT selection from the synthesis methodology	Additional technology
R-DWC	(i)	(ii)	(i)		(i)	(ii)		Advantageous (Rank 1)	iii, vi
R-HiGee			(i)			(ii)		Advantageous (Rank 4)	iii, vi
R-HIDiC			(i)	(ii)	(i)			Advantageous (Rank 3)	iii, vi
CCD			(i)					Feasible	iii, vi
MA-RD	(i)		(i)		(i)		(ii)	Advantageous (Rank 2)	iii

^a(i) Preconcentration, (ii) catalyst safeguarding technologies, (iii) additional separation for extra streams, (iv) additional separation at different pressures, (v) azeotrope-oriented technologies, and (vi) membrane module.

issues of a more complex system. These findings, along with the reduction of the reaction window identified,⁵ demonstrate that

the effect of side reactions could be detected in an early stage and influence the selection of technologies.

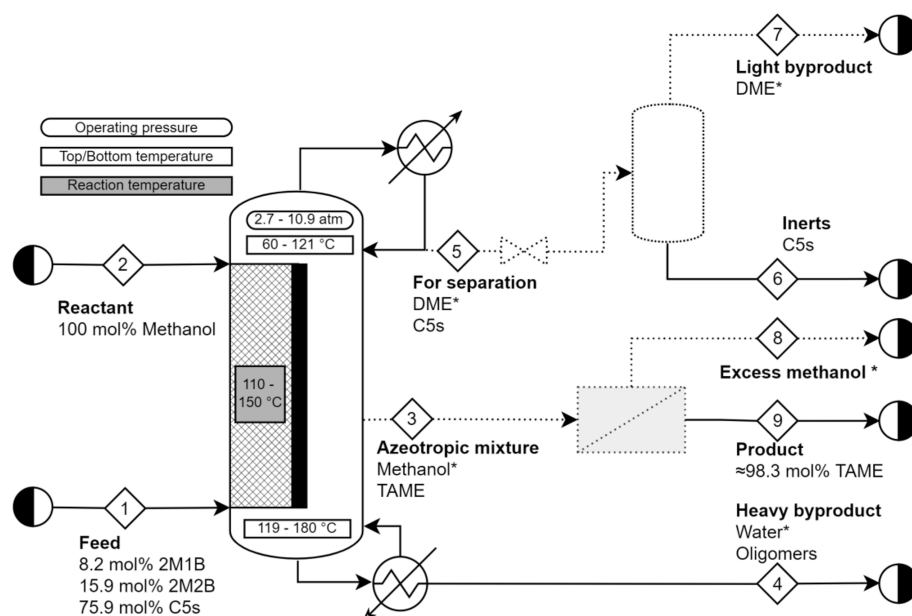

Figure 11. PFD for the TAME system (scenario 2) for an R-DWC including a membrane module and flash separation (*when excess methanol is fed to the system).

For Scenario 1, R-HIDiC shows advantages due to the small ΔT_b . The potential of R-HIDiC is corroborated by published simulation studies.^{70–72} Babaie and Nasr Esfahany⁷³ added a pervaporation module to R-HIDiC to overcome the azeotrope between (unreacted) methanol and isopentane. This result agrees with the suggestion of an additional membrane module to complement the operation of ARDT.

When accounting for side reactions in Scenario 2, R-DWC is suggested as the most advantageous followed by MA-RD, R-HIDiC, and R-HiGee. To date, no studies have included side reactions in simulations for conventional RD or ARDT. Therefore, further rigorous modeling studies for the production of TAME, including side reactions, are recommended to assess the impacts of side reactions on process performance.

5.4. Production of Methyl Acetate. **5.4.1. Description of the Process and the Design Problem.** The methyl acetate industrial process is well-known and has been thoroughly studied, hence the availability of data and various benchmark configurations.⁷⁴ One method for methyl acetate production is the esterification of methanol and acetic acid. A general overview of the methyl acetate system is provided in Table S10, numerical values are included in Table S11, and reactions are given in eqs S13 and S14 in the Supporting Information.

5.4.2. Methodology Application and Outcomes. The feeds to the esterification process consist of pure acetic acid and a slight excess of methanol.^{75–79}

- Step 1: Components participating in the system, including byproducts from dehydration of methanol, are listed in Table 9. Four outlet streams are expected, thus requiring an additional separation unit to complement the operation of R-DWC and MA-RD.
- Step 2: The ΔT_b is about 61 °C at atmospheric pressure. ΔT_b is slightly larger than 60 °C; hence, three scenarios were evaluated due to the closeness to the threshold value: (a) two sliding windows for systems with $\Delta T_b < 60$ °C and one sliding window for systems with $\Delta T_b > 60$ °C where (b1) operates at vacuum and (b2) operates above atmospheric pressure.

Table 9. List of Components, Nature, and Splits for the Methyl Acetate System

components	nature	NBP (°C)	output stream ^a
dimethyl ether	byproduct	−24.8	1
methyl acetate (LR)	product	56.9	2
methanol	reactant	64.7	3
water	byproduct	100.0	4
acetic acid (HR)	reactant	117.9	-

^aStream numbers correspond to the flowsheet in Figure 12.

- Step 3: Reactions involved are the esterification of acetic acid with methanol and the potential dehydration of methanol into DME, which are presented in eqs S13 and S14 in the Supporting Information. The reaction rate constant for the esterification of acetic acid calculated at 90 and 120 °C (maximum reaction temperature) has an order of magnitude of 10^{-3} , so the technologies suggested are R-DWC, R-HIDiC, and MA-RD. Dehydration of methanol occurs in parallel with the esterification of lactic acid. Thus, R-DWC is recommended to deal with the side reaction.
- Step 4: The mixture is nonideal and exhibits two low-boiling azeotropes: methyl acetate-methanol and methyl acetate-water.⁸⁰ The normal boiling point and types of azeotropes are detailed in Table S12 in the Supporting Information. As a result, the ester product is usually removed as the methanol-methyl acetate azeotrope, whose treatment has been studied in various membrane applications.^{81–90} Hence, MA-RD could potentially be used.

Table 10 presents three decision-making matrices, denoting the alternatives found when evaluating basic properties and operating windows in Step 2.

The three scenarios agree on identifying R-DWC and MA-RD as advantageous. In addition, case (a) suggests using R-HIDiC to take advantage of the close boiling components. Case (b1) operating at vacuum also suggests R-HiGee. Following well-

Table 10. Decision-Making Matrices for the Methyl Acetate System

a) $\Delta T_b < 60^\circ\text{C}$

Criteria	Number of outlet streams	Product cut location	Vacuum operation	ΔT_b	Reaction rate constant	Side reactions	Azeotropes	ARDT selection from the synthesis methodology	Additional technology ^a
R-DWC	Ⓜ	Ⓢ	Ⓜ		Ⓜ	Ⓢ		Advantageous (Rank 1)	iii, vi
R-HiGee			Ⓜ					Feasible	iii, vi
R-HIDiC			Ⓜ	Ⓢ	Ⓜ			Advantageous (Rank 3)	iii, vi
CCD			Ⓜ					Feasible	iii, vi
MA-RD	Ⓜ		Ⓜ		Ⓜ		Ⓢ	Advantageous (Rank 2)	iii

b1) $\Delta T_b > 60^\circ\text{C}$ with operation at vacuum

Criteria	Number of outlet streams	Product cut location	Vacuum operation	ΔT_b	Reaction rate constant	Side reactions	Azeotropes	ARDT selection from the synthesis methodology	Additional technology ^a
R-DWC	Ⓜ	Ⓢ	Ⓢ	Ⓜ	Ⓜ	Ⓢ		Advantageous (Rank 1)	iii, vi
R-HiGee			Ⓢ	Ⓜ				Advantageous (Rank 3)	iii, vi
R-HIDiC			Ⓧ	Ⓧ	Ⓜ			Not applicable	iii, vi
CCD			Ⓧ	Ⓜ				Not applicable	iii, vi
MA-RD	Ⓜ		Ⓜ	Ⓜ	Ⓜ		Ⓢ	Advantageous (Rank 2)	iii

b1) $\Delta T_b > 60^\circ\text{C}$ with operation above atmospheric

Criteria	Number of outlet streams	Product cut location	Vacuum operation	ΔT_b	Reaction rate constant	Side reactions	Azeotropes	ARDT selection from the synthesis methodology	Additional technology ^a
R-DWC	Ⓜ	Ⓢ	Ⓜ	Ⓜ	Ⓜ	Ⓢ		Advantageous (Rank 1)	iii, vi
R-HiGee			Ⓜ	Ⓜ				Feasible	iii, vi
R-HIDiC			Ⓜ	Ⓧ	Ⓜ			Not applicable	iii, vi
CCD			Ⓜ	Ⓜ				Feasible	iii, vi
MA-RD	Ⓜ		Ⓜ	Ⓜ	Ⓜ		Ⓢ	Advantageous (Rank 2)	iii

^a(i) Preconcentration, (ii) catalyst safeguarding technologies, (iii) additional separation for extra streams, (iv) additional separation at different pressures, (v) azeotrope-oriented technologies, and (vi) membrane module.

known heuristics, avoiding vacuum conditions is desired; hence, R-HiGee is unlikely to be necessary. Therefore, R-DWC, MA-RD, and R-HIDiC represent advantageous processing options that could be further evaluated. Due to the number of outlet streams required and the azeotrope occurring close to the desired split, additional separation and the use of a membrane module can complement the operation.

Figure 12 presents the potential flowsheet configurations, including auxiliary equipment and operating conditions. The first ranked is an R-DWC including a membrane module (a), then an MA-RD including a flash separation unit (b), and finally an R-HIDiC including a flash separation unit and a membrane module when exploiting the closeness in boiling points (c).

This case study was proposed to demonstrate the flexibility of the synthesis methodology as the decision-making flowchart provides guidelines that could be adapted as the evaluation progresses. This is important because, from a practical point of view, the proposed approach allows potential processing options to be identified systematically. The methodology provides arguments as to why one technology might be advantageous while others are discarded according to the context and targets of the design problem. Although the results from evaluating operating windows that account for ARDT⁵ are preliminary for this case study, the observations provide valuable insights for selecting technologies, and the results are verified with published studies.

5.4.3. Comparison of the Results of the Methodology with the Literature. The esterification of organic acids, particularly acetic acid, has been thoroughly studied in both traditional and hybrid processes.⁷⁴ Experimental and modeling studies have

been performed, including control structures applied for RD applications.^{42,75,76,80,91} Aiming to improve the performance of RD, an R-DWC at atmospheric pressure presented benefits in terms of TAC compared to a sequence of RD and conventional distillation and showed better dynamic performance than a single RD using a stoichiometric feed ratio.⁷⁹ Integration of a membrane module to RD to overcome the methanol-methyl acetate azeotrope has not been described in the literature, although independent membrane studies have been performed.^{81,83–86,89} Babi et al.⁹¹ presented a synthesis-intensification framework that emphasizes the importance of membranes to improve sustainability. However, ARDT were not included in the framework. Therefore, an interesting next step will be the study of an MA-RD for the production of methyl acetate, which could be compared with various configurations (conventional and intensified) to assess its benefits.

Finally, R-HIDiC was deemed advantageous when considering the closeness of boiling points. However, published studies^{92–95} have applied R-HIDiC to the hydrolysis of methyl acetate, which is the reverse reaction. The decision-making process for the hydrolysis of methyl acetate is detailed in the Supporting Information, including the decision-making matrix and flowchart, highlighting decision points (e.g., the change in the product cut location, no side reactions, and the azeotrope located far from the split) that drive the selection of technologies in a different direction. From the comparison, the occurrence of DME with the esterification of acetic acid could affect the temperature profile along the column. Therefore, a light component could present challenges for the operation of the compressor. Further studies are recommended to assess the

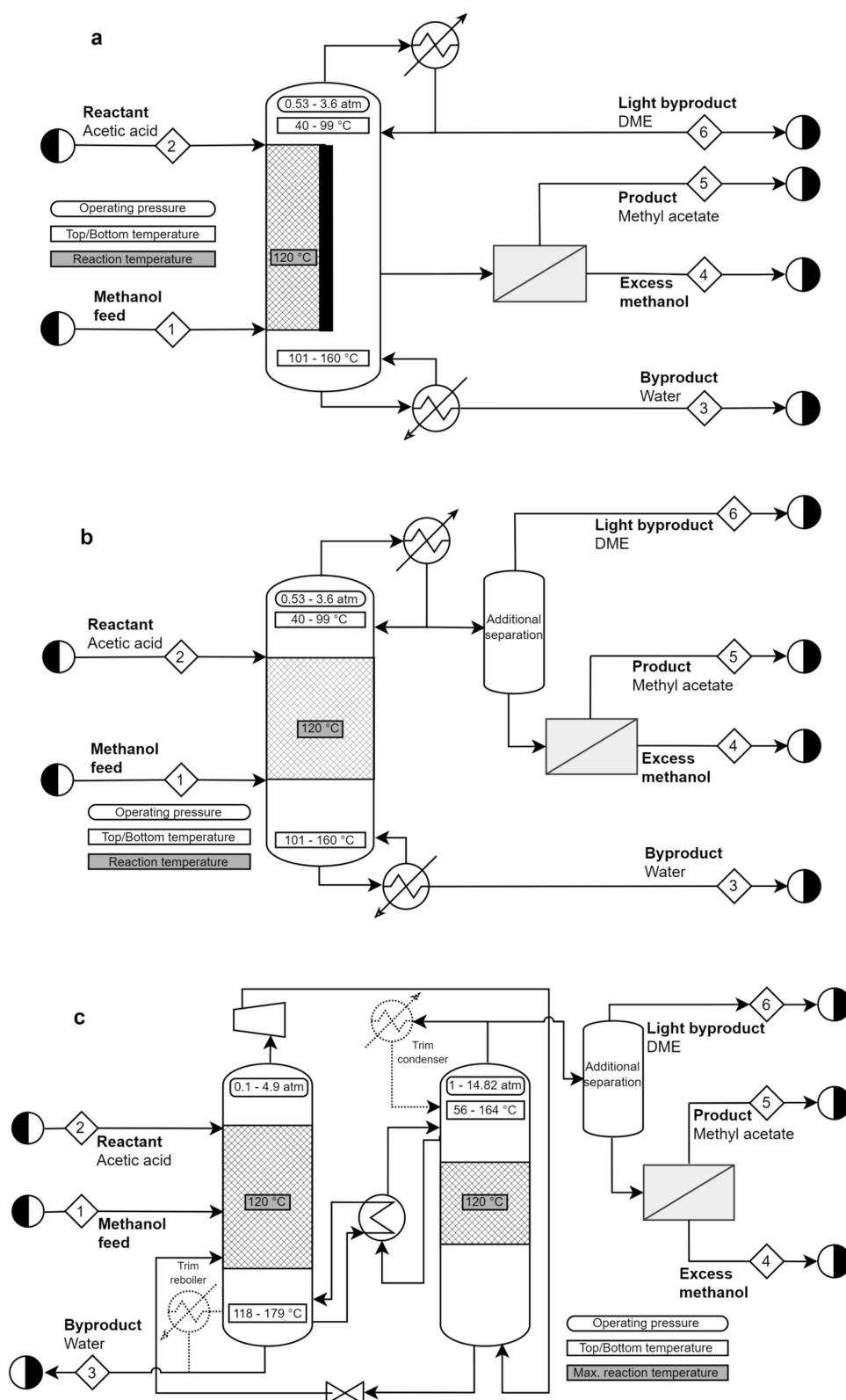

Figure 12. PFDs for the methyl acetate system: R-DWC (a), MA-RD (b), and R-HIDiC (c).

applicability of R-HIDiC for the esterification of acetic acid to assess the impact of the dehydration of methanol.

5.5. Production of Cyclohexane. 5.5.1. *Description of the Process and the Design Problem.* Cyclohexane is an important raw material in the petrochemical industry, mainly obtained through benzene hydrogenation.⁹⁶ Separating benzene from

cyclohexane is challenging because of their close boiling points and azeotrope. Various techniques have been investigated for the separation of the benzene–cyclohexane mixture.^{97–100}

Therefore, this case study explores the application of ARDT for a typical hydrogenation reaction. An overview of the

cyclohexane system is summarized in Table S15 in the Supporting Information.

5.5.2. Methodology Application and Outcomes.

- Step 1: The benzene feed contains a considerable amount of C5–C9 paraffins and other aromatics, as detailed in Table S16 in the Supporting Information. The feed is also likely to contain sulfur compounds, so a guard reactor can be used. Inert paraffins need to be removed, which is considered when defining the splits, while cumene tends to react with hydrogen—a side reaction. Table 11 lists the

Table 11. List of Components, Nature, and Splits for the Cyclohexane System

components	nature	NBP (°C)	output stream ^a
hydrogen	reactant	−252.8	1
<i>n</i> -pentane (LR)	inert impurity	36.1	2
methyl cyclopentane	byproduct	71.8	2
benzene	reactant	80.1	3 ^b
cyclohexane	product	80.7	5
2,3-dimethyl pentane	inert impurity	89.8	4
<i>n</i> -heptane	inert impurity	98.4	4
methyl cyclohexane	byproduct	100.9	4
toluene	reactive impurity	110.6	4
<i>m</i> -xylene	inert impurity	139.1	4
cumene (HR)	inert impurity	152.4	4

^aStream numbers correspond to the flowsheet in Figure 13. ^bWhen benzene is not fully converted.

components in the order of increasing boiling point and denotes their nature. The most difficult split is to separate benzene and cyclohexane due to their close boiling points. Benzene can be fully or partially converted. If full conversion is achieved, no benzene will exit the system. However, if benzene is not fully converted, it is expected to exit the system along with cyclohexane. Due to the number of streams that need to be removed, an additional separation unit could complement the operation of ARDT. The product stream, cyclohexane, is mid-boiling, so the use of an R-DWC helps its removal as a side draw.

- Step 2: Hydrogen is not considered as a representative component because it is a gas that will not condense, and its boiling temperature is far from that of other compounds. As a result, the light and heavy representative compounds are *n*-pentane and cumene, respectively. The ΔT_b is about 116 °C at atmospheric pressure. The reaction section is limited by the thermal degradation of *n*-pentane at 260 °C. The suggested operating pressure

ranges between 1.13 and 14.22 atm, so the ARDT evaluated could operate at these conditions. As for ΔT_b , R-DWC, R-HiGee, CCD, and MA-RD could cover those temperature ranges without needing additional units.

- Step 3: Hydrogenation of benzene to produce cyclohexane could be accompanied by hydrogenation of toluene into methyl cyclohexane (parallel reaction) and isomerization of cyclohexane into methyl cyclopentane (series reaction), eqs S15–S17 in the Supporting Information. Kinetic data are scarce, particularly for the reaction in the liquid phase and the type of catalyst, where the latter is usually kept as a trade secret, according to Mahindrakar and Hahn.¹⁰¹ Reaction rate values at different temperatures are provided in Table S16 in the Supporting Information. The reaction rate order for the hydrogenation of benzene, which is within the temperature range evaluated in the operating window, fluctuates between 10^{-5} and 10^{-4} , which can be favored with the use of CCD. Regarding side reactions, reference values are provided but under conditions outside the range of pressures identified in the operating window. However, Campbell¹⁰² provided a qualitative reference for the isomerization reaction, which could be slow enough if temperatures are controlled. Although the side reactions cannot be represented in the operating windows due to the lack of data in the required conditions, identifying the types of reactions could provide guidance to select R-DWC and R-HiGee since they could help prevent side reactions.
- Step 4: The system exhibits two homogeneous azeotropes (Table S17 in the Supporting Information). The most problematic azeotrope occurs between benzene and cyclohexane, which is pressure-sensitive and disappears above two atmospheres. A membrane module could be added to overcome the azeotrope in case benzene is not fully converted and exits the system.

Results of the methodology are summarized in Table 12, where R-DWC is ranked as the most advantageous technology followed by MA-RD and CCD. Additional separation is needed to obtain all the streams. Two additional units—a guard bed reactor and a membrane—are included to deal with sulfur compounds in the feed and the azeotrope between benzene and cyclohexane, respectively. The application in the decision-making flowchart is illustrated in Figure S7 in the Supporting Information.

A potential process flowsheet is presented in Figure 13, including potential operation conditions. The guard bed reactor

Table 12. Decision-Making Matrix for the Cyclohexane System

Criteria	Number of outlet streams	Product cut location	Vacuum operation	ΔT_b	Reaction rate constant	Side reactions	Azeotropes	ARDT selection from the synthesis methodology	Additional technology ^a
R-DWC	⚠	✔	⚠	⚠		✔		Advantageous (Rank 1)	ii, iii, vi
R-HiGee			⚠	⚠	✘	✔		Not applicable	ii, iii, vi
R-HiDiC			⚠	✘				Not applicable	ii, iii, vi
CCD			⚠	⚠	✔			Advantageous (Rank 3)	ii, iii, vi
MA-RD	⚠		⚠	⚠			✔	Advantageous (Rank 2)	ii, iii, vi

^a(i) Preconcentration, (ii) catalyst safeguarding technologies, (iii) additional separation for extra streams, (iv) additional separation at different pressures, (v) azeotrope-oriented technologies, and (vi) membrane module.

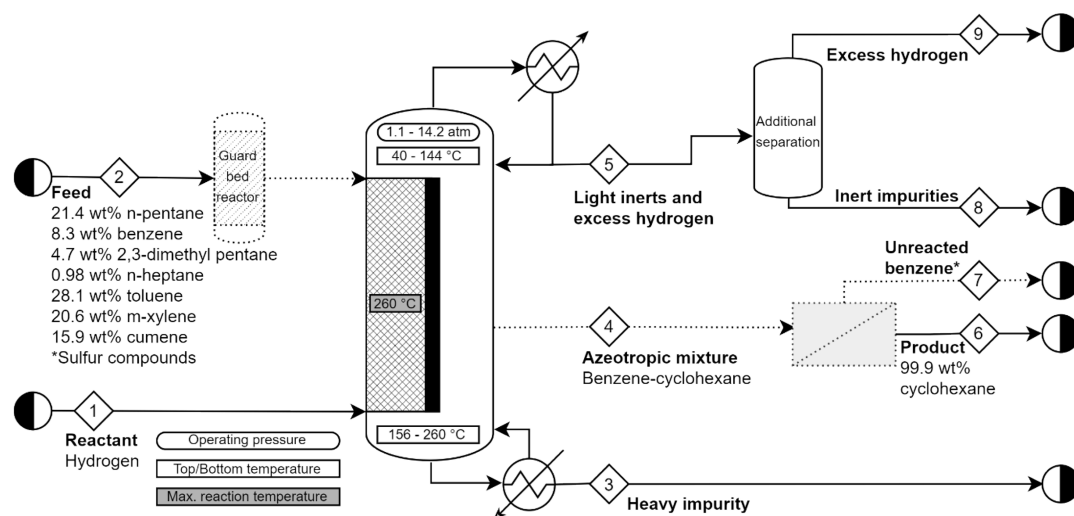

Figure 13. PFD for the cyclohexane system for an R-DWC (*case-dependent components; optional units are denoted with dotted lines).

and the membrane module are denoted with dotted lines to indicate that they are optional.

This case study aimed to demonstrate the application of ARDT in a system where one reactant is a gas that reacts in the liquid phase while in contact with a catalyst. This is important because a range of systems with a gaseous reactant, typically requiring high temperatures and pressures, could be explored and be benefited from the simultaneous reaction and separation in RD at less severe conditions. Additionally, this case study demonstrated that a small number of kinetic data points or qualitative information is valuable in providing guidance for the decision-making flowchart, at least at an early stage.

5.5.3. Comparison of the Results of the Methodology with the Literature. Hydrogenation of benzene in RD is reported in a few studies regarding process control and one patent.^{101,103,104} However, studies are yet to be performed to evaluate ARDT. Although preliminary, having identified R-DWC, MA-RD, and CCD as advantageous provides a good starting point not only for embarking on more rigorous simulations but for identifying additional studies needed to complement the evaluation, particularly regarding kinetics and the types of catalysts.

6. CONCLUSIONS

This work successfully proposed and validated a systematic synthesis methodology to assess ARDT to identify features to qualify them as advantageous, technically feasible, or not applicable. This methodology allows the evaluation of different scenarios to understand the effect of operating conditions, side reactions, dilute feeds, and azeotropes, which are typically overlooked in the early stages of process design. The results can be presented in a process flowsheet including units to complement the operation of ARDT to solve the design problem. Thus, this study strongly contributes to integrate the evaluation of intensified units, whose evaluation is normally technology-oriented, into the process systems engineering approach to obtain an initial process flow diagram.

The methodology was successfully applied and demonstrated in five case studies that are industrially relevant. From a practical point of view, testing different chemical systems demonstrates the robustness and flexibility of the methodology to provide a basis for the selection of technologies. From a methodological point of view, this is the first time that ARDT are considered in a systematic synthesis methodology using a combination of first

principles (thermodynamic properties and kinetic parameters) and heuristics. The results from the synthesis methodology are verified with results from other published studies. The main findings of each case study are as follows:

- Purification of lactic acid: It is a special case where a reactive separating agent is introduced to promote a reversible reaction to overcome a difficult separation. It also demonstrates the effects of a reactive impurity. R-DWC was the most advantageous technology because it favors the removal of various outlet streams, particularly the product cut, and could potentially help prevent side reactions.
- Production of dimethyl ether: CCD is deemed potentially advantageous because of the large residence times provided. However, R-DWC and MA-RD were also identified to be feasible and were also evaluated in published studies. Thus, complementary studies are recommended to allow a more quantitative comparison.
- Production of *tert*-amyl methyl ether: This case study evaluated the effect of side reactions. While R-HIDiC and MA-RD are identified as equally advantageous when side reactions are not considered, R-DWC offers more advantages when accounting for side reactions because of the additional outlet streams, the location of the product cut, and the need to inhibit undesired reactions. In this manner, the methodology provided guidance for selecting technologies accompanied by insights about the parameters influencing the selection, which could inform further kinetic and catalytic studies.
- Production of methyl acetate: This case study demonstrated the flexibility of the methodology that could be adapted according to the objectives of the design problem. R-DWC was identified as the most favorable technology in all scenarios, but the next best technologies varied based on considerations or assumptions tailored to a particular application.
- Production of cyclohexane: This case study investigated a system that includes a gaseous reactant, where R-DWC was found to be the most advantageous. It is worth noting that additional units are also suggested throughout the decision-making flowchart to complement the operation of ARDT and provide a potential process configuration.

For the case studies evaluated, R-HiGee is either considered not applicable or is ranked after other more advantageous technologies. This could be attributed to the fact that the reaction systems evaluated presented slow to intermediate reaction rates, while R-HiGee is deemed advantageous for very fast reactions (where side reactions must be avoided). Therefore, applications featuring relatively fast reactions could potentially find advantages in the use of R-HiGee.

The proposed synthesis methodology finds limitations when complex feeds and reaction networks increase the number of interdependent interactions that cannot be evaluated. Despite the exploratory nature of the methodology, its guidelines assist the selection of technologies and contribute to the development of basic process flowsheets that include ARDT that have not been considered in previous approaches.

Further research should be carried out to understand the interplay of mass and heat transfer and miscibility gaps in ARDT. These investigations will contribute to the future development of methodologies to assist in process synthesis and design. For example, introducing dimensionless numbers, such as the Damköhler and Hatta numbers, will allow operating parameters and hardware characteristics of ARDT to be considered. In addition, cost estimates, which cannot be done at this stage due to the screening nature of the methodology, could be introduced to provide a quantitative measure for comparison. Opportunities for heat integration could be explored by introducing more complex configurations, such as heat integration in thermally coupled reactive distillation sequences, in later stages of the (detailed) process design.

■ ASSOCIATED CONTENT

SI Supporting Information

The Supporting Information is available free of charge at <https://pubs.acs.org/doi/10.1021/acs.iecr.2c04540>.

Comprehensive reference for the data used as an input for the application of the synthesis methodology to the case studies (PDF)

■ AUTHOR INFORMATION

Corresponding Authors

Isabel Pazmiño-Mayorga – Department of Chemical Engineering, Centre for Process Integration, The University of Manchester, Manchester M13 9PL, United Kingdom; Email: isabel.pazminomayorga@manchester.ac.uk

Anton A. Kiss – Department of Chemical Engineering, Delft University of Technology, Delft 2629 HZ, The Netherlands; orcid.org/0000-0001-5099-606X; Email: tonykiss@gmail.com

Author

Megan Jobson – Department of Chemical Engineering, Centre for Process Integration, The University of Manchester, Manchester M13 9PL, United Kingdom; The Institution of Chemical Engineers (IChemE), Rugby CV21 3HQ, United Kingdom; orcid.org/0000-0001-9626-5879

Complete contact information is available at: <https://pubs.acs.org/doi/10.1021/acs.iecr.2c04540>

Notes

The authors declare no competing financial interest.

■ ACKNOWLEDGMENTS

I.P.-M. gratefully acknowledges full fund support from SENESCYT-Ecuador.

■ REFERENCES

- (1) Van Gerven, T.; Stankiewicz, A. Structure, Energy, Synergy, Time—The Fundamentals of Process Intensification. *Ind. Eng. Chem. Res.* **2009**, *48*, 2465–2474.
- (2) Kiss, A. A. 4. Process Intensification by Reactive Distillation. In *Process Synthesis and Process Intensification Methodological Approaches*; De Gruyter: Berlin, Boston, 2017. DOI: [10.1515/9783110465068-004](https://doi.org/10.1515/9783110465068-004).
- (3) Sundmacher, K.; Kienle, A. *Reactive Distillation: Status and Future Directions*; Wiley VCH: Weinheim, 2002.
- (4) Kiss, A. A.; Jobson, M.; Gao, X. Reactive Distillation: Stepping up to the next Level of Process Intensification. *Ind. Eng. Chem. Res.* **2019**, *58*, 5909–5918.
- (5) Pazmiño-Mayorga, I.; Jobson, M.; Kiss, A. A. Operating Windows for Early Evaluation of the Applicability of Advanced Reactive Distillation Technologies. *Chem. Eng. Res. Des.* **2023**, *189*, 485–499.
- (6) Luyben, W. L. *Distillation Design and Control Using Aspen Simulation*, 2nd ed.; Wiley: Hoboken, NJ, 2013.
- (7) Skiborowski, M. Process Synthesis and Design Methods for Process Intensification. *Curr. Opin. Chem. Eng.* **2018**, *22*, 216–225.
- (8) Keil, F. J. Process Intensification. *Rev. Chem. Eng.* **2018**, *34*, 135–200.
- (9) Doherty, M. F.; Malone, M. F. *Conceptual Design of Distillation Systems*; McGraw-Hill chemical engineering series; McGraw: Boston, MA, 2001.
- (10) Shah, M.; Kiss, A. A.; Zondervan, E.; de Haan, A. B. A Systematic Framework for the Feasibility and Technical Evaluation of Reactive Distillation Processes. *Chem. Eng. Process. Process Intensif.* **2012**, *60*, 55–64.
- (11) Muthia, R.; Reijneveld, A. G. T.; van der Ham, A. G. J.; ten Kate, A. J. B.; Bargeman, G.; Kersten, S. R. A.; Kiss, A. A. Novel Method for Mapping the Applicability of Reactive Distillation. *Chem. Eng. Process. - Process Intensif.* **2018**, *128*, 263–275.
- (12) Holtbruegge, J.; Kuhlmann, H.; Lutze, P. Conceptual Design of Flowsheet Options Based on Thermodynamic Insights for (Reaction-) Separation Processes Applying Process Intensification. *Ind. Eng. Chem. Res.* **2014**, *53*, 13412–13429.
- (13) Garg, N.; Kontogeorgis, G. M.; Gani, R.; Woodley, J. M. A Process Synthesis-Intensification Method for Generation of Novel and Intensified Solutions. *Chem. Eng. Process.* **2020**, *156*, 108103.
- (14) Weinfeld, J. A.; Owens, S. A.; Eldridge, R. B. Reactive Dividing Wall Columns: A Comprehensive Review. *Chem. Eng. Process.* **2018**, *123*, 20–33.
- (15) Mueller, I.; Kenig, E. Y. Reactive Distillation in a Dividing Wall Column: Rate-Based Modeling and Simulation. *Ind. Eng. Chem. Res.* **2007**, *46*, 3709–3719.
- (16) Kaibel, B. Chapter 5 - Dividing-Wall Columns. In *Distillation*; Górák, A., Olujić, Ž., Eds.; Academic Press: Boston, 2014; pp. 183–199. DOI: [10.1016/B978-0-12-386878-7.00005-X](https://doi.org/10.1016/B978-0-12-386878-7.00005-X).
- (17) Cortes Garcia, G. E.; van der Schaaf, J.; Kiss, A. A. A Review on Process Intensification in HiGee Distillation. *J. Chem. Technol. Biotechnol.* **2017**, *92*, 1136–1156.
- (18) Neumann, K.; Gladyszewski, K.; Groß, K.; Qammar, H.; Wenzel, D.; Górák, A.; Skiborowski, M. A Guide on the Industrial Application of Rotating Packed Beds. *Chem. Eng. Res. Des.* **2018**, *134*, 443–462.
- (19) Quarderer, G. J.; Trent, D. L.; Stewart, E. J.; Tirtowidjojo, D.; Mehta, A. J.; Tirtowidjojo, C. A. Method for Synthesis of Hypohalous Acid. US6048513A, 2000.
- (20) Sudhoff, D. Introduction to Centrifugally Enhanced Separations. In *Process Intensification: by Rotating Packed Beds*; Skiborowski, M., Górák, A., Eds.; De Gruyter: Berlin, Boston, 2022; pp. 1–34. DOI: [10.1515/9783110724998-001](https://doi.org/10.1515/9783110724998-001).

- (21) Li, W.; Song, B.; Li, X.; Liu, Y. Modelling of Vacuum Distillation in a Rotating Packed Bed by Aspen. *Appl. Therm. Eng.* **2017**, *117*, 322–329.
- (22) Kiss, A. A.; Olujić, Ž. A Review on Process Intensification in Internally Heat-Integrated Distillation Columns. *Chem. Eng. Process. Process Intensif.* **2014**, *86*, 125–144.
- (23) Wakabayashi, T.; Hasebe, S. Higher Energy Saving with New Heat Integration Arrangement in Heat-Integrated Distillation Column. *AIChE J.* **2015**, *61*, 3479–3488.
- (24) Suphanit, B. Design of Internally Heat-Integrated Distillation Column (HIDIc): Uniform Heat Transfer Area versus Uniform Heat Distribution. *Energy* **2010**, *35*, 1505–1514.
- (25) Kiss, A. A. *Advanced Distillation Technologies: Design, Control, and Applications*; Wiley: Chichester, West Sussex, United Kingdom, 2013; DOI: 10.1002/9781118543702.
- (26) Pătruț, C.; Bildea, C. S.; Kiss, A. A. Catalytic Cyclic Distillation – A Novel Process Intensification Approach in Reactive Separations. *Chem. Eng. Process. Process Intensif.* **2014**, *81*, 1–12.
- (27) Kiss, A.; Maleta, V. Cyclic Distillation Technology - A New Challenger in Fluid Separations. *Chem. Eng. Trans.* **2018**, *69*, 823–828.
- (28) Lutze, P.; Gorak, A. Reactive and Membrane-Assisted Distillation: Recent Developments and Perspective. *Chem. Eng. Res. Des.* **2013**, *91*, 1978–1997.
- (29) Holtbrügge, J. 6 Membrane-Assisted (Reactive) Distillation. In *Reactive and Membrane-Assisted Separations*; De Gruyter: Berlin, Boston, 2016. DOI: 10.1515/9783110307849-008.
- (30) Pazmiño-Mayorga, I.; Kiss, A. A.; Jobson, M. Synthesis of Advanced Reactive Distillation Technologies: Early-Stage Assessment Based on Thermodynamic Properties and Kinetics. In *Computer Aided Chemical Engineering*; Yamashita, Y., Kano, M., Eds.; 14 International Symposium on Process Systems Engineering; Elsevier, 2022; Vol. 49, pp. 643–648. DOI: 10.1016/B978-0-323-85159-6.50107-X.
- (31) Pazmiño-Mayorga, I.; Kiss, A. A.; Jobson, M. High-Level Decision-Making Approach for Early Assessment of the Applicability of Advanced Reactive Distillation Technologies. In *The 12th international conference Distillation & Absorption 2022*; Toulouse, 2022.
- (32) Tylko, M.; Barkmann, S.; Sand, G.; Schembecker, G.; Engell, S. Synthesis of Reactive Separation Processes. In *Integrated reaction and separation operations: Modelling and experimental validation*; Schmidt-Traub, H., Gorak, A., Eds.; Springer: Berlin, Heidelberg, 2006; pp. 7–94. DOI: 10.1007/3-540-30304-9_2.
- (33) Kiss, A. A.; Segovia-Hernández, J. G.; Bildea, C. S.; Miranda-Galindo, E. Y.; Hernández, S. Reactive DWC Leading the Way to FAME and Fortune. *Fuel* **2012**, *95*, 352–359.
- (34) Albuquerque, A. A.; Ng, F. T. T.; Danielski, L.; Stragevitch, L. A New Process for Biodiesel Production from Tall Oil via Catalytic Distillation. *Chem. Eng. Res. Des.* **2021**, *170*, 314–328.
- (35) Goortani, B. M.; Gaurav, A.; Deshpande, A.; Ng, F. T. T.; Rempel, G. L. Production of Isooctane from Isobutene: Energy Integration and Carbon Dioxide Abatement via Catalytic Distillation. *Ind. Eng. Chem. Res.* **2015**, *54*, 3570–3581.
- (36) Díaz Velázquez, H.; Likhanova, N.; Aljammal, N.; Verpoort, F.; Martínez-Palou, R. New Insights into the Progress on the Isobutane/Butene Alkylation Reaction and Related Processes for High-Quality Fuel Production. A Critical Review. *Energy Fuels* **2020**, *34*, 15525–15556.
- (37) Talwalkar, S.; Chauhan, M.; Aghalayam, P.; Qi, Z.; Sundmacher, K.; Mahajani, S. Kinetic Studies on the Dimerization of Isobutene with Ion-Exchange Resin in the Presence of Water as a Selectivity Enhancer. *Ind. Eng. Chem. Res.* **2006**, *45*, 1312–1323.
- (38) Sinnott, R.; Towler, G. *Chemical Engineering Design*; Butterworth-Heinemann, 2020. DOI: 10.1016/B978-0-08-102599-4.00015-1.
- (39) Smith, R. *Chemical Process Design and Integration*, 2nd ed.; Wiley-Blackwell: Chichester, West Sussex, United Kingdom, 2016.
- (40) Fidkowski, Z. T. Distillation Configurations and Their Energy Requirements. *AIChE J.* **2006**, *52*, 2098–2106.
- (41) Masel, R. H.; Smith, D. W.; Luyben, W. L. Use of Two Distillation Columns in Systems with Maximum Temperature Limitations. *Ind. Eng. Chem. Res.* **2013**, *52*, 5172–5176.
- (42) Luyben, W. L.; Yu, C.-C. *Reactive Distillation Design and Control*; Wiley-Blackwell: Hoboken, N.J., 2008.
- (43) Schildhauer, T. J.; Hoek, I.; Kapteijn, F.; Moulijn, J. A. Zeolite BEA Catalysed Esterification of Hexanoic Acid with 1-Octanol: Kinetics, Side Reactions and the Role of Water. *Appl. Catal. A Gen.* **2009**, *358*, 141–145.
- (44) Gudena, K.; Rangaiah, G. P.; Lakshminarayanan, S. Modeling and Analysis of Solid Catalyzed Reactive HiGee Stripping. *Chem. Eng. Sci.* **2012**, *80*, 242–252.
- (45) Lei, Z.; Zou, Z.; Dai, C.; Li, Q.; Chen, B. Synthesis of Dimethyl Ether (DME) by Catalytic Distillation. *Chem. Eng. Sci.* **2011**, *66*, 3195–3203.
- (46) Ortega, C.; Hessel, V.; Kolb, G. Dimethyl Ether to Hydrocarbons over ZSM-5: Kinetic Study in an External Recycle Reactor. *Chem. Eng. J.* **2018**, *354*, 21–34.
- (47) Bildea, C. S.; György, R.; Brunchi, C. C.; Kiss, A. A. Optimal Design of Intensified Processes for DME Synthesis. *Comput. Chem. Eng.* **2017**, *105*, 142–151.
- (48) van der Schaaf, J.; Schouten, J. High-Gravity and High-Shear Gas–Liquid Contactors for the Chemical Process Industry. *Curr. Opin. Chem. Eng.* **2011**, *1*, 84–88.
- (49) Martín, M.; Adams, T. A. Future Directions in Process and Product Synthesis and Design. In *Computer Aided Chemical Engineering*; Eden, M. R., Ierapetritou, M. G., Towler, G. P., Eds.; 13 International Symposium on Process Systems Engineering (PSE 2018); Elsevier, 2018; Vol. 44, pp. 1–10. DOI: 10.1016/B978-0-444-64241-7.50001-X.
- (50) Alves de Oliveira, R.; Komesu, A.; Vaz Rossell, C. E.; Maciel Filho, R. Challenges and Opportunities in Lactic Acid Bioprocess Design—From Economic to Production Aspects. *Biochem. Eng. J.* **2018**, *133*, 219–239.
- (51) Cho, Y.; Kim, B.; Kim, D.; Han, M. Recovery of Lactic Acid by Reactive Dividing Wall Column; IEEE 2008; pp. 2596–2599. DOI: 10.1109/ICCCAS.2008.4694294.
- (52) Kim, S. Y.; Kim, D. M.; Lee, B. Process Simulation for the Recovery of Lactic Acid Using Thermally Coupled Distillation Columns to Mitigate the Remixing Effect. *Korean J. Chem. Eng.* **2017**, *34*, 1310–1318.
- (53) Pazmiño-Mayorga, I.; Jobson, M.; Kiss, A. A. Conceptual Design of a Dual Reactive Dividing Wall Column for Downstream Processing of Lactic Acid. *Chem. Eng. Process.* **2021**, *164*, 108402.
- (54) Gudena, K.; Rangaiah, G. P.; Samavedham, L. Modeling and Optimization of Reactive HiGee Stripper-Membrane Process for Methyl Lactate Hydrolysis. *Ind. Eng. Chem. Res.* **2013**, *52*, 7795–7802.
- (55) Park, S.-J.; Han, K.-J.; Gmehling, J. Vapor–Liquid Equilibria and HE for Binary Systems of Dimethyl Ether (DME) with C1–C4 Alkan-1-ols at 323.15 K and Liquid–Liquid Equilibria for Ternary System of DME + Methanol + Water at 313.15 K. *J. Chem. Eng. Data* **2007**, *52*, 230–234.
- (56) Kiss, A. A.; Bildea, C. S.; Pătruț, C. Process and Installation for the Production of Dialkyl Ether. CA2936291A1, 2015.
- (57) Rasmussen, J. B.; Stevnsborg, M.; Mansouri, S. S.; Zhang, X.; Abildskov, J.; Huusom, J. K. Quantitative Metrics for Evaluating Reactive Cyclic Distillation Performance. *Chem. Eng. Process.* **2022**, *174*, 108843.
- (58) Kiss, A.; Suszwalak, D. J.-P. C. Enhanced Dimethyl Ether Synthesis by Reactive Distillation in a Dividing-Wall Column. *Proc. Eng.* **2012**, *42*, 581–587.
- (59) Gor, N. K.; Mali, N. A.; Joshi, S. S. Intensified Reactive Distillation Configurations for Production of Dimethyl Ether. *Chem. Eng. Process.* **2020**, *149*, 107824.
- (60) Liu, J.; Gao, L.; Liu, X.; Ren, J.; Dong, M.; Sun, L. Evolutional Design and Plant-Wide Control for Dimethyl Ether Production by Combining Dynamic Process Intensification and Evaporation Membranes. *Ind. Eng. Chem. Res.* **2022**, *61*, 4920–4936.

- (61) Su, W.-B.; Hwang, J.-H.; Huang, H.-Y.; Chang, T.-K. Dehydration of Methanol to Dimethyl Ether in a Dual-Catalyst System Catalytic Distillation Tower. *J. Taiwan Inst. Chem. Eng.* **2016**, *59*, 86–90.
- (62) Klöker, M.; Kenig, E.; Górak, A.; Fraczek, K.; Salacki, W.; Orlikowski, W. Experimental and Theoretical Studies of the TAME Synthesis by Reactive Distillation. In *Computer Aided Chemical Engineering*; Kraslawski, A., Turunen, I., Eds.; European Symposium on Computer Aided Process Engineering-13; Elsevier, 2003; Vol. 14, pp. 713–718. DOI: 10.1016/S1570-7946(03)80200-6.
- (63) Cruz, V. J.; Izquierdo, J. F.; Cunill, F.; Tejero, J.; Iborra, M.; Fité, C.; Bringué, R. Kinetic Modelling of the Liquid-Phase Dimerization of Isoamylenes on Amberlyst 35. *React. Funct. Polym.* **2007**, *67*, 210–224.
- (64) Subawalla, H.; Fair, J. R. Design Guidelines for Solid-Catalyzed Reactive Distillation Systems. *Ind. Eng. Chem. Res.* **1999**, *38*, 3696–3709.
- (65) Marx, S.; Everson, R. C.; Neomagus, H. W. J. P. Organic–Organic Separation by Pervaporation. II. Separation of Methanol from Tame by an A-Alumina Supported Nay-Zeolite Membrane. *Sep. Sci. Technol.* **2005**, *40*, 1047–1065.
- (66) Hung, P. D.; Masawaki, T.; Tone, S. Pervaporation Separation of Methanol from Methanol–t-Amyl Methyl Ether Mixture by Polyion Complex Membrane. *J. Chem. Eng. Jpn.* **1998**, *31*, 484–487.
- (67) Marx, S.; Neomagus, H.; Everson, R.; Keizer, K. Pervaporation Separation of Methanol from Methanol/Tert-Amyl Methyl Ether Mixtures with a Commercial Membrane. *J. Membr. Sci.* **2002**, *209*, 353–362.
- (68) Boz, N.; Dogu, T. Reflux–Recycle–Reactor for High Yield and Selectivity in TAME and TAEE Production. *AIChE J.* **2005**, *51*, 631–640.
- (69) Kołodziej, A.; Jaroszyński, M.; Salacki, W.; Orlikowski, W.; Fraczek, K.; Klöker, M.; Kenig, E. Y.; Górak, A. Catalytic Distillation for TAME Synthesis with Structured Catalytic Packings. *Chem. Eng. Res. Des.* **2004**, *82*, 175–184.
- (70) Gao, X.; Wang, F.; Li, H.; Li, X. Heat-Integrated Reactive Distillation Process for TAME Synthesis. *Sep. Purif. Technol.* **2014**, *132*, 468–478.
- (71) Pulido, J. L.; Martínez, E. L.; Maciel, M. R. W.; Filho, R. M. Heat Integrated Reactive Distillation Column (r-HIDiC): Implementing a New Technology Distillation. *Chem. Eng. Trans.* **2011**, *24*, 1303–1308.
- (72) Vanaki, A.; Eslamloueyan, R. Steady-State Simulation of a Reactive Internally Heat Integrated Distillation Column (R-HIDiC) for Synthesis of Tertiary-Amyl Methyl Ether (TAME). *Chem. Eng. Process. Process Intensif.* **2012**, *52*, 21–27.
- (73) Babaie, O.; Nasr Esfahany, M. Optimization and Heat Integration of Hybrid R-HIDiC and Pervaporation by Combining GA and PSO Algorithm in TAME Synthesis. *Sep. Purif. Technol.* **2020**, *236*, 116288.
- (74) Bayer, B.; Eggersmann, M.; Gani, R.; Schneider, R. Chapter 7.1 - Case Studies in Design & Analysis. In *Computer Aided Chemical Engineering*; Braunschweig, B., Gani, R., Eds.; Software Architectures and Tools for Computer Aided Process Engineering; Elsevier, 2002; Vol. 11, pp. 591–634. DOI: 10.1016/S1570-7946(02)80026-8.
- (75) Pöpken, T.; Steinigeweg, S.; Gmehling, J. Synthesis and Hydrolysis of Methyl Acetate by Reactive Distillation Using Structured Catalytic Packings: Experiments and Simulation. *Ind. Eng. Chem. Res.* **2001**, *40*, 1566–1574.
- (76) Al-Arfaj, M. A.; Luyben, W. L. Comparative Control Study of Ideal and Methyl Acetate Reactive Distillation. *Chem. Eng. Sci.* **2002**, *57*, 5039–5050.
- (77) Krishna, G.; Min, T. H.; Rangaiah, G. P. Modeling and Analysis of Novel Reactive HiGee Distillation. In *Computer Aided Chemical Engineering*; Karimi, I. A., Srinivasan, R., Eds.; 11 International Symposium on Process Systems Engineering; Elsevier, 2012; Vol. 31, pp. 1201–1205. DOI: 10.1016/B978-0-444-59506-5.50071-7.
- (78) Zuo, C.; Pan, L.; Cao, S.; Li, C.; Zhang, S. Catalysts, Kinetics, and Reactive Distillation for Methyl Acetate Synthesis. *Ind. Eng. Chem. Res.* **2014**, *53*, 10540–10548.
- (79) An, D.; Cai, W.; Xia, M.; Zhang, X.; Wang, F. Design and Control of Reactive Dividing-Wall Column for the Production of Methyl Acetate. *Chem. Eng. Process. Process Intensif.* **2015**, *92*, 45–60.
- (80) Ganesh, B.; Rani, K. Y.; Satyavathi, B.; Patnaik, K. S. K. R. Experimental Analysis in Different Batch Operating Units for Process Intensification: Methyl Acetate Production Case Study. *Int. J. Ind. Chem.* **2014**, *5*, 85–93.
- (81) Abdallah, H.; El-Gendi, A.; El-Zanati, E.; Matsuura, T. Pervaporation of Methanol from Methylacetate Mixture Using Polyamide-6 Membrane. *Desalination Water Treat.* **2013**, *51*, 7807–7814.
- (82) Ahmad, F.; Lau, K. K.; Shariff, A. M.; Fong Yeong, Y. Temperature and Pressure Dependence of Membrane Permeance and Its Effect on Process Economics of Hollow Fiber Gas Separation System. *J. Membr. Sci.* **2013**, *430*, 44–55.
- (83) Genduso, G.; Farrokhzad, H.; Latré, Y.; Darvishmanesh, S.; Luis, P.; Van der Bruggen, B. Polyvinylidene Fluoride Dense Membrane for the Pervaporation of Methyl Acetate–Methanol Mixtures. *J. Membr. Sci.* **2015**, *482*, 128–136.
- (84) Gorri, D.; Ibáñez, R.; Ortiz, I. Comparative Study of the Separation of Methanol–Methyl Acetate Mixtures by Pervaporation and Vapor Permeation Using a Commercial Membrane. *J. Membr. Sci.* **2006**, *280*, 582–593.
- (85) Li, Y.; Zong, C.; Zhou, H.; Jin, W. Pervaporative Separation of Methyl Acetate–Methanol Azeotropic Mixture Using High-Performance Polydimethylsiloxane/Ceramic Composite Membrane. *Asia-Pac. J. Chem. Eng.* **2019**, *14*, No. e2343.
- (86) Lux, S.; Winkler, T.; Körbler, M.; Siebenhofer, M. Assessment of Pervaporative Separation of Methyl Acetate and Methanol Using Organophilic Membranes. *Chem. Eng. Sci.* **2017**, *158*, 500–508.
- (87) Penkova, A. V.; Polotskaya, G. A.; Toikka, A. M. Separation of Acetic Acid–Methanol–Methyl Acetate–Water Reactive Mixture. *Chem. Eng. Sci.* **2013**, *101*, 586–592.
- (88) Sain, S.; Dincer, S.; Savaşçı, Ö. T. Pervaporation of Methanol–Methyl Acetate Binary Mixtures. *Chem. Eng. Process. Process Intensif.* **1998**, *37*, 203–206.
- (89) Tong-Hu, X.; Xiao-Li, X.; Hai-Jiao, Q.; Xiao-Gang, Y.; Rui-Feng, Z. Zeolite 4A-Incorporated Polymeric Membranes for Pervaporation Separation of Methanol–Methyl Acetate Mixtures. *J. Inorg. Organomet. Polym. Mater.* **2011**, *21*, 816–822.
- (90) Zong, C.; Guo, Q.; Shen, B.; Yang, X.; Zhou, H.; Jin, W. Heat-Integrated Pervaporation–Distillation Hybrid System for the Separation of Methyl Acetate–Methanol Azeotropes. *Ind. Eng. Chem. Res.* **2021**, *60*, 10327–10337.
- (91) Babi, D. K.; Lutze, P.; Woodley, J. M.; Gani, R. A Process Synthesis-Intensification Framework for the Development of Sustainable Membrane-Based Operations. *Chem. Eng. Process. Process Intensif.* **2014**, *86*, 173–195.
- (92) Chen, H.; Li, X.; He, L.; Cong, H. Energy, Exergy, Economic, and Environmental Analysis for Methyl Acetate Hydrolysis Process with Heat Integrated Technology Used. *Energy Convers. Manage.* **2020**, *216*, 112919.
- (93) Lee, H.-Y.; Lee, Y.-C.; Chien, I.-L.; Huang, H.-P. Design and Control of a Heat-Integrated Reactive Distillation System for the Hydrolysis of Methyl Acetate. *Ind. Eng. Chem. Res.* **2010**, *49*, 7398–7411.
- (94) Li, L.; Sun, L.; Wang, J.; Zhai, J.; Liu, Y.; Zhong, W.; Tian, Y. Design and Control of Different Pressure Thermally Coupled Reactive Distillation for Methyl Acetate Hydrolysis. *Ind. Eng. Chem. Res.* **2015**, *54*, 12342–12353.
- (95) Zhai, J.; Liu, Y.; Sun, L.; Wang, R. A Novel Thermally Coupled Reactive Distillation Column for the Hydrolysis of Methyl Acetate. *China Pet. Process. Petrochem. Technol.* **2015**, *17*, 101–108.
- (96) Li, W.; Xu, B.; Lei, Z.; Dai, C. Separation of Benzene and Cyclohexane by Extractive Distillation Intensified with Ionic Liquid. *Chem. Eng. Process.* **2018**, *126*, 81–89.
- (97) Garcia Villaluenga, J. P.; Tabe-Mohammadi, A. A Review on the Separation of Benzene/Cyclohexane Mixtures by Pervaporation Processes. *J. Membr. Sci.* **2000**, *169*, 159–174.

(98) Xi, T.; Lu, Y.; Ai, X.; Tang, L.; Yao, L.; Hao, W.; Cui, P. Ionic Liquid Copolymerized Polyurethane Membranes for Pervaporation Separation of Benzene/Cyclohexane Mixtures. *Polymer* **2019**, *185*, 121948.

(99) Zahlan, H.; Saeed, W. S.; Alqahtani, S.; Aouak, T. Separation of Benzene/Cyclohexane Mixtures by Pervaporation Using Poly (Ethylene-Co-Vinylalcohol) and Carbon Nanotube-Filled Poly (Vinyl Alcohol-Co-Ethylene) Membranes. *Separations* **2020**, *7*, 68.

(100) Zhang, Y.; Lin, L.; Wang, Q.; Qiang, R.; Gao, Y.; Ma, S.; Cheng, Q.; Zhang, Y. Polyrotaxane Crosslinked Modified EC/PVDF Composite Membrane Displaying Simultaneously Enhanced Pervaporation Performance and Solvent Resistance for Benzene/Cyclohexane Separation. *J. Mater. Sci.* **2020**, *55*, 8403–8419.

(101) Mahindrakar, V.; Hahn, J. Dynamics and Control of Benzene Hydrogenation via Reactive Distillation. *J. Process Control* **2014**, *24*, 113–124.

(102) Campbell, M.; L., Cyclohexane. In *Ullmann's Encyclopedia of Industrial Chemistry*; John Wiley & Sons, Ltd, 2011. DOI: 10.1002/14356007.a08_209.pub2.

(103) Gildert, G. R. Hydrogenation of Benzene to Cyclohexane. US6187980B1, 2001.

(104) Mahindrakar, V.; Hahn, J. Model Predictive Control of Reactive Distillation for Benzene Hydrogenation. *Control Eng. Pract.* **2016**, *52*, 103–113.

Recommended by ACS

Merging Renewable Carbon-Based Materials and Emerging Separation Concepts to Attain Relevant Purification Applications in a Circular Economy

Adolfo M. Avila and María E. Araoz

MARCH 20, 2023

INDUSTRIAL & ENGINEERING CHEMISTRY RESEARCH

READ 

Population Balance Modeling and Mechanistic Analysis of Inorganic Pigment Dispersion in a High-Speed Disk Disperser and a Vertical Bead Mill

Shicong Luo, Søren Kiil, *et al.*

MARCH 17, 2023

INDUSTRIAL & ENGINEERING CHEMISTRY RESEARCH

READ 

Optimization of Flexible Nacre-Like Cellulose Nanofiber Films by a Covalent Overlapping Method: Excellent Thermal Conductivity and Superior Flame Resistance

Jiachen Guo, Chunzhong Li, *et al.*

MARCH 31, 2023

INDUSTRIAL & ENGINEERING CHEMISTRY RESEARCH

READ 

Nanocomposite of CO₂-Based Polycarbonate Polyol with Highly Exfoliated Nanoclay

Mohammad Alroaithi and Wei Xu

JANUARY 31, 2023

ACS OMEGA

READ 

Get More Suggestions >