

Influence of printing direction on 3D-printed vascular based self-healing cementitious composites

Wan, Zhi; Xu, Yading; Šavija, Branko

DOI

[10.1051/matecconf/2023337802027](https://doi.org/10.1051/matecconf/2023337802027)

Publication date

2023

Document Version

Final published version

Published in

MATEC web of conferences

Citation (APA)

Wan, Z., Xu, Y., & Šavija, B. (2023). Influence of printing direction on 3D-printed vascular based self-healing cementitious composites. In *MATEC web of conferences: SMARTINCS'23 Conference on Self-Healing, Multifunctional and Advanced Repair Technologies in Cementitious Systems* (Vol. 378). Article 02027 (MATEC web of conferences). EDP Sciences. <https://doi.org/10.1051/matecconf/2023337802027>

Important note

To cite this publication, please use the final published version (if applicable).
Please check the document version above.

Copyright

Other than for strictly personal use, it is not permitted to download, forward or distribute the text or part of it, without the consent of the author(s) and/or copyright holder(s), unless the work is under an open content license such as Creative Commons.

Takedown policy

Please contact us and provide details if you believe this document breaches copyrights.
We will remove access to the work immediately and investigate your claim.

Influence of printing direction on 3D-printed vascular based self-healing cementitious composites

Zhi Wan^{1*}, Yading Xu¹, and Branko Šavija¹

¹Faculty of Civil Engineering and Geosciences, Delft University of Technology, 2628CN Delft, the Netherlands

Abstract. Compared with other self-healing mechanisms, embedding vascular networks in cementitious matrix enables repairing wider cracks and performing multiple healing cycles. For vascular-based self-healing cementitious composites, additive manufacturing (AM) allows fabricating vascular structures with complex geometry. For Fused Filament Fabrication (FFF), printing direction has great influences on the properties of the 3D-printed vascular network. To timely release the healing agent when cracks occur, selecting the proper printing direction for the vascular network in self-healing concretes is necessary. In this work, two commercial printing filaments, i.e., polylactic acid (PLA) and polyvinyl alcohol (PVA), are used to create the vascular structures. The influence of printing direction on the dissolution of 3D-printed PVA structure is investigated. Besides, the flexural strength and water tightness of samples with PLA vascular printed in different printing directions are compared. After the 4-point bending tests, epoxy resin is manually injected into the vascular networks to seal the cracks. It is found that the strength recovery and the permeability of the cracked specimens are influenced by the printing direction due to the different crack closure after unloading.

1 Introduction

Concrete deterioration is inevitable due to its susceptibility to cracking, which results in significant maintenance and repair costs. Among the possible crack-repair strategies, self-healing concrete is promising as cracks could be sealed with no or little human intervention [1]. Inspired by the human cardiovascular system and plant vascular tissue system, embedding vascular networks in a host matrix enables transporting healing agents to the crack areas. The main advantage of vascular based self-healing materials is the continuous supply of healing agents, which facilitates healing wider cracks and repeating the healing process. Except for the healing agents [2], vascular material also plays a key role in the properties of vascular based self-healing materials. The vascular material must be strong enough to survive concrete mixing and casting, but brittle enough to fracture when cracks appear. Glass has been widely used as the encapsulation material because of its brittleness [3][4]. One problem of glass vascular is the alkali-silica reaction, which affects the service life of the vascular based self-healing concretes. Alternatively, other brittle materials have been used to create the vascular networks [5]. However, the existence of vascular wall may influence the triggering of self-healing process if it does not rupture timely. To address this, some researchers created hollow channels inside the host matrix to serve as the path for transporting healing agents. In the beginning, researchers preplaced solid bars in the moulds prior to concrete casting, which were subsequently removed after concrete setting to

create hollow channels [6]. Inspired by the structure of bones, Sangadji et al.[7] used porous network concrete as the flow path to heal the cracks. Davies [8] employed the heat shrinking tubing or polyurethane tubing to create a 2D vascular network in cementitious materials.

Recently, the development of additive manufacturing (AM, also known as 3D printing) allowed fabricating vascular structures with complex geometry [9]. The selection of printing materials is vital considering the bonding between the 3D-printed vascular network and the cementitious matrix. Li et al. [10] designed a biomimetic 3D vascular network based on Murray's law for circulatory blood volume transfer, and the vascular network was printed with polylactic acid (PLA) filament. Similarly, Tsangouri et al. [11] analysed the healing performance of cementitious composites embedded with 3D-printed PLA vascular network using acoustic emission, digital image correction and ultrasound velocity. Acrylonitrile Butadiene Styrene (ABS) is another commonly-used 3D printing filament for its good interlayer adhesion and high chemical resistance. Wan et al.[12] fabricated octet-shape vascular networks with ABS and then embedded the vascular in the cementitious composite. Li et al.[13] explored the feasibility of using Polyvinyl Alcohol (PVA) as the printing material to create hollow channels for self-healing to eliminate the influence from vascular wall. Except for the geometry of vascular network, the printing parameters such as printing direction also influences the properties of the 3D-printed vascular based self-healing concrete.

* Corresponding author: Z.Wan-1@tudelft.nl

Therefore, in this study, it is experimentally investigated the influence of printing direction on the self-healing cementitious composite embedded with 3D-printed vascular networks. Two widely-used printing filaments, i.e., polylactic acid (PLA, Ultimaker PLA filament with a diameter of 2.85mm) and polyvinyl alcohol (PVA, Ultimaker PVA filament with a diameter of 2.85mm), were used to create the vascular structures. The dissolution of 3D-printed PVA hollow tubes under different printing direction (horizontal/vertical) was first studied. In addition, hollow tubes were printed with PLA in three printing direction (horizontal/vertical/inclined). Afterwards, PVA/PLA tubes and PLA connectors were assembled and embedded in the cementitious mortar as the vascular network. The mechanical properties under 4-point bending were investigated. Subsequently, epoxy resin was manually injected through the 3D-printed vascular network to seal the cracks. The healing efficiency in terms of flexural strength and water tightness recovery of the 3D-printed PLA vascular based self-healing mortar was discussed.

2 Experiment details

2.1 Fabrication of vascular network

Considering that Polyvinyl Alcohol (PVA) is water dissolvable printing material, the dissolution of the PVA tubes embedded in cementitious matrix is studied when the printing direction is different. Based on the previous research [10], PVA reacts with $\text{Ca}(\text{OH})_2$ and Calcite (CaCO_3) in the cementitious matrix which influences the dissolution of PVA. To isolate PVA tubes from the cementitious matrix, the PVA tubes were coated spraying with paraffin wax with a low melting temperature. The specimens embedded with PVA tubes were cured in water under room temperature for 7 days before being observed with X-ray computed tomography (XCT, Phoenix Nanotom). The curing water was changed daily considering a possible reaction between the dissolved PVA in water and cementitious matrix.

The diameters of the interior channels in the vascular network are designed according to Murray's law to minimise the work required for healing agent transportation [14]. Two printing parts, i.e., tubes in the possible crack region (under 4-point bending load) and the PLA connector in the rest part, are separately printed and then assembled. For PVA, the printing direction showing better dissolution of hollow tubes is used to create the tubes in the vascular network. For PLA, the tubes are printed in three different directions to investigate the influence on the properties of the specimens embedded with vascular networks. The printing directions of PLA tubes are selected as horizontal, vertical and inclined (with an angle of 45°). The main printing parameters for PVA and PLA tubes are shown in Table 1.

The mechanical properties and the permeability of the cracked specimens embedded with PLA vascular network before and after healing process are studied.

The schematics of vascular networks with different printing directions is shown in Figure 1.

Table 1. Printing parameters for PVA and PLA

Printing parameters	Values
Nozzle temperature	225°C(PVA), 210°C(PLA)
Nozzle size	0.04mm
Printing speed	30mm/s
Layer height	0.06mm

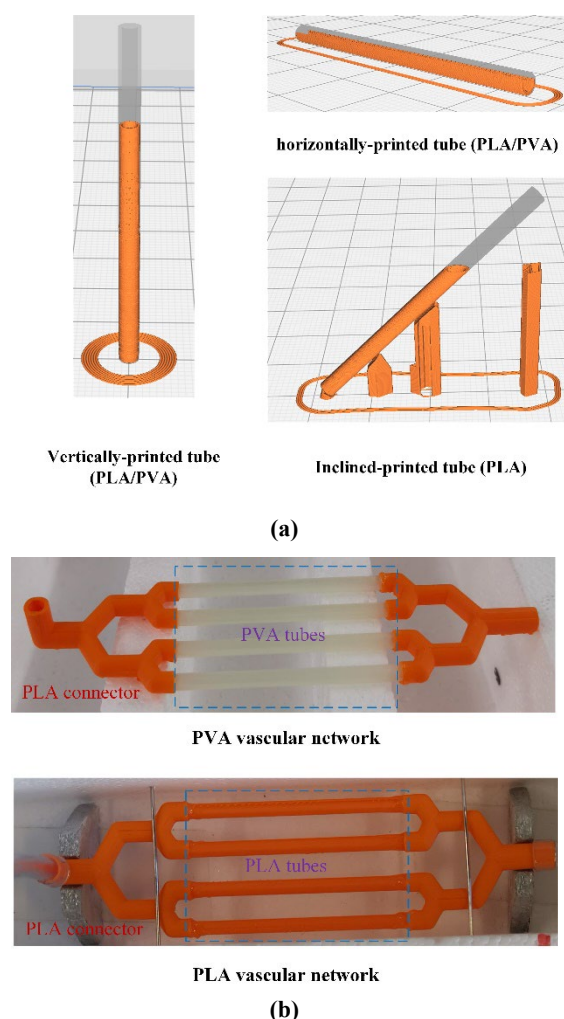

Fig. 1. Schematic of vascular network under different printing directions (a) Tubes printed in different printing directions; (b) Schematic of vascular network

2.2 Casting and curing

After fabrication, the 3D-printed vascular network was assembled and then embedded in the cementitious matrix. For comparison, the parent tubes of the vascular network (PLA connector) were kept in the middle of height in the samples. The schematics of the samples embedded with vascular network is shown in Figure 2.

The mix design of the vascular based self-healing concrete refers to [12] and it is shown in Table 2. For the specimens embedded with PVA vascular network, 0.1% of PE fibres were added to the matrix mortar by volume to avoid sudden break of the specimens according to [15].

Table 2. Mix design of cementitious matrix (kg/m³)

Component	Weight
CEM I 42.5 N	550
Fly ash	650
Sand (0.125-0.25)	550
Superplasticizer (Glenium 51)	2
Water	395

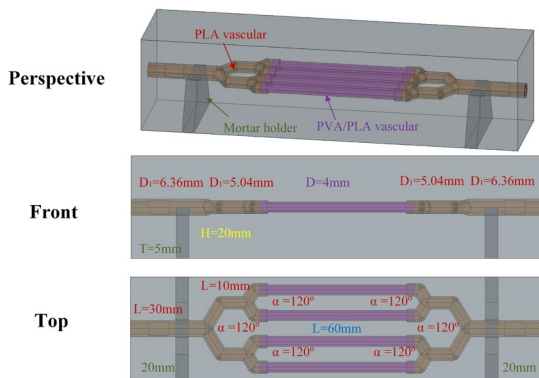

Fig. 2. Schematic of vascular network embedded in cementitious matrix

2.3 Four-point bending test

Four-point bending tests were performed to investigate the mechanical property of the specimens embedded with 3D-printed PLA vascular networks. A constant crack opening speed of 0.5µm/s is employed with Linear Variable Differential Transformers (LVDT, Solartron, range=1000µm; accuracy=0.001µm) during the test based on the previous research [16]. The virgin specimens were loaded until the crack width reached 400µm. After unloading, epoxy resin (Resin: Conpox Resin BY 158; Hardener: Conpox Hardener BY 2996, supplied by Condor Kemi A/S) was injected with a syringe connected to the vascular network to seal the crack induced by the 4-point bending tests. The specimens were loaded again after the injected epoxy resin was totally hardened. The cracking and healing process was carried out multiple times, until it became difficult to manually inject the epoxy resin into the vascular networks. For each 4-point bending test, the healed specimens were loaded until the crack width reached 400µm. The flexural strength in each test was

recorded and compared. A schematics of the 4-point bending set-up could be seen in Figure 3.

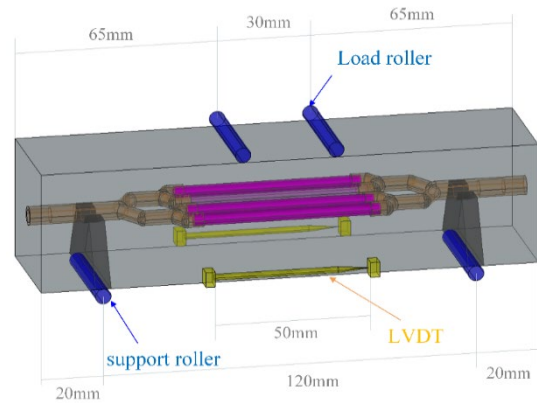

Fig. 3. Schematics of four-point bending test

2.4 Permeability test

Permeability test was carried out on the cracked specimens to assess the water tightness before and after the healing process [12]. During the test, one end of the vascular network was closed while the other end was connected to a tube, which was connected to a water container with a water head of 0.75m (measured from the upper surface of the tested specimens.) The amount of leaked water before and after the 4-point bending tests was recorded and compared.

3 Results and Discussion

3.1 Dissolution of PVA tubes in different printing directions

The samples embedded with single PVA tubes were first scanned by XCT to study the influence of printing direction on the dissolution of PVA tubes. The result is shown in Figure 4. Note that the black part in the figures represents the air.

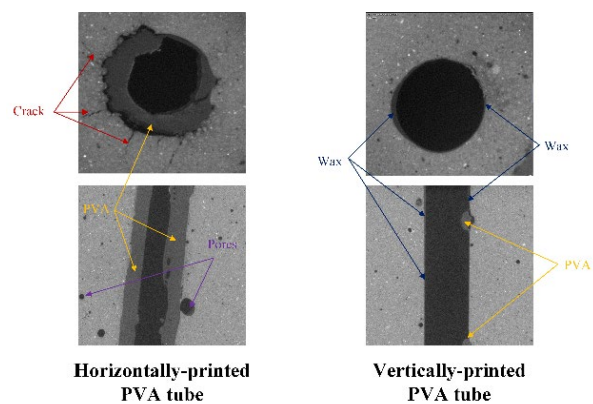

Fig. 4. Dissolution of PVA tubes in different printing directions

From Figure 4, it is noted that the dissolution of PVA tubes printed in two directions was quite different. When the PVA tube was horizontally printed, a lot of PVA is undissolved in the scanned sample. The interface between the PVA tube and the cementitious

matrix is rough, manifesting that PVA tube reacted with the cementitious materials. Therefore, the wax coating does not completely isolate the horizontally-printed PVA tube from the cementitious matrix. A possible reason is that the printing quality of the horizontally-printed PVA is poor and there are some defects in the inter-layers. Cementitious slurry possibly leaks into the PVA tubes through these defects. The reaction between PVA and cementitious matrix also induces cracks in the matrix. Those cracks may have an adverse influence on the mechanical properties of the self-healing concrete embedded with vascular networks. Therefore, it is not recommended to print the PVA tube in horizontal direction for vascular network.

Compared with the horizontally-printed PVA tubes, the PVA tubes printed in vertical direction was almost completely dissolved and no cracks occurred around the tube. The interface between the cementitious matrix and the tube was smooth. Therefore, the coated wax successfully prevented the vertically-printed PVA tube from reacting with the cementitious matrix. Although most of the vertically-printed PVA tube was well dissolved, a part remained. This is caused by the uneven wax coating layer.

Based on the obtained results, a vascular network with vertically-printed PVA tube in the middle part was created and embedded in cementitious matrix. After curing in water for 7 days, the sample was scanned to observe the dissolution of PVA part in the vascular network. The XCT result is shown in Figure 5. The PVA tubes in the middle part of the vascular network were almost dissolved and the hollow channels could therefore be used for transporting healing agent when cracks occur.

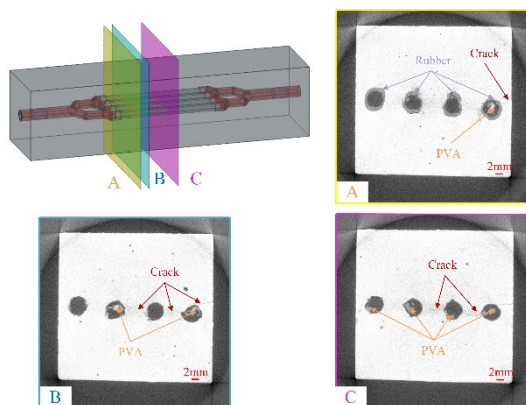

Fig. 5. Dissolution of PVA tubes in vascular network embedded in cementitious matrix

3.2 Flexural strength of PLA vascular based self-healing concrete

Besides the PVA tubes, vascular networks with PLA tubes in the middle part were also created and embedded in cementitious matrix. Four-point bending tests were carried out to investigate the flexural strength before and after the healing process. The flexural stress-crack width curve is shown in Figure 6(a). In addition, the flexural strengths of the specimens with vascular network printed in different directions are compared and the result is shown in Figure 6(b).

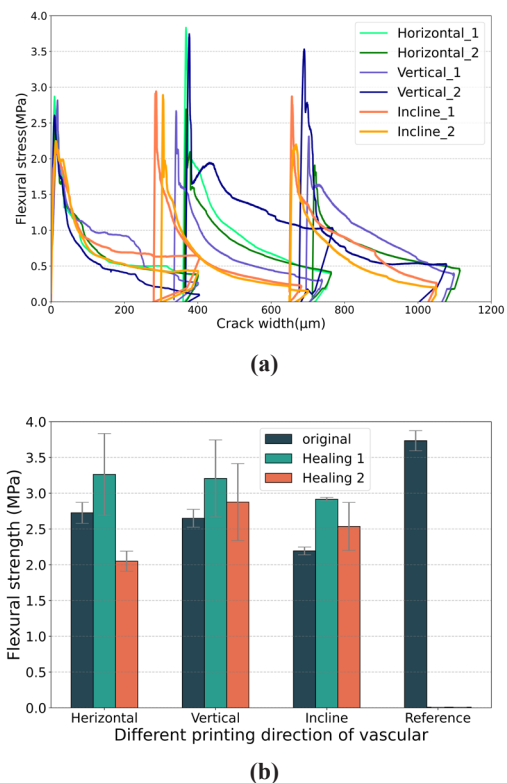

Fig. 6. Flexural response of specimens embedded with PLA tubes printed in different directions (a) stress-crack width curve; (b) Flexural strength in different healing cycles

As shown in Figure 6, the existence of vascular network compromises the initial flexural strength compared with the reference samples. The post-peak stresses of the three types of specimens are very similar and all of them show softening behaviours. Compared with other two kinds of specimens, the specimens with inclined-printed PLA tubes have higher stress at the crack width of 400μm. Besides, according to Figure 6(a), the crack closure of the specimen with this printing configuration was the largest after unloading. When looking at the influence of printing direction on the initial property of vascular based self-healing samples, the flexural strength of inclined-printed samples was slightly lower than that of the vertically-/horizontally-printed vascular samples.

As to the mechanical recovery in different healing cycles, the trend is similar: the flexural strengths of the healed specimens are higher than that of the original specimens. In other words, the healing efficiencies of all of the vascular based self-healing concretes are higher than 100% according to the definition in [12]. Compared with the results after the second healing cycle, the flexural strength after the first healing cycle is higher for the three scenarios. As to the influence of printing direction on the healed specimens, the flexural strength of the inclined-printed samples is lower than the vertically-/horizontally-printed counterparts. This could be caused by the residual epoxy resin hardened in the vascular after the first healing process, although pressurized air was used to remove the excess epoxy resin from the vascular network. As a result, less epoxy resin flowed into the crack during the second healing process. As to the mechanical recovery after the second

healing cycle, the specimen embedded with vertically-printed vascular network had the highest flexural strength compared with the other two counterparts. However, the variance of flexural strength after the second healing cycle is very large.

To investigate the vascular network of specimens after the second healing cycle, the specimens were cut in the mid-height section to directly observe the crack morphology as well as the vascular network. The result is shown in Figure 7. It is noted that the cutting face is not always in the middle interface so that part of vascular networks is invisible due to the cutting inaccuracy.

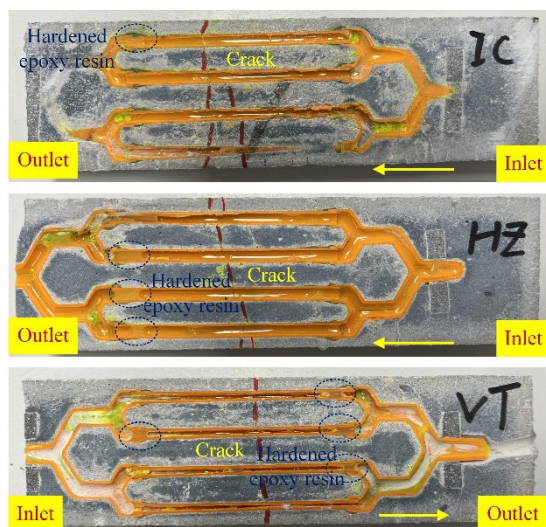

Fig. 7. Vascular network after the second healing process

As shown in Figure 7, some channels in the vascular network were blocked by the hardened epoxy resin after the healing process. For the three samples, the hardened epoxy resin was located in the secondary joint near the outlet. Compared with the vertically-/horizontally-printed specimens, the block of incline-printed sample was less severe. Therefore, the specimen embedded with the incline printed vascular network could be employed for more healing cycles.

The crack morphology could also be observed. It is worth mentioning that cracks occur between the two load rollers for all the specimens. In other words, the crack does not initiate at the PLA connector, and the printing direction of PLA tubes could represent the printing direction of the whole vascular networks. Unlike the samples embedded with horizontally/incline printed vascular networks, there is only one crack in the one with the vertically printed tubes. In other words, the healed crack reopens in the following 4-point bending tests. For the vertical samples, the loading direction is perpendicular to the printing direction of vascular networks, resulting in the brittle behaviour of the vertically-printed vascular networks.

3.3 Permeability test result

The influence of printing direction on the permeability of the cracked specimens is also investigated. The permeability of the specimens after the first 4-point

bending test is shown in Figure 8. There are three samples in each group.

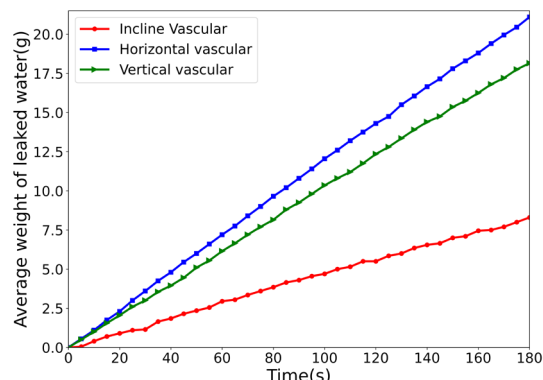

Fig. 8. The change of leaked water with time

According to Figure 8, the permeability of the cracked specimens is influenced by the printing direction of the vascular networks. Compared with the specimens embedded with horizontally-/vertically-printed vascular networks, the incline-printed samples have lower permeability. The difference is caused by the different crack closure after unloading. From Figure 6(a), it could be found that the incline-printed samples have much larger crack closure. As a result, the permeability of the incline-printed specimens is lower. Except for the permeability, the final crack width after unloading also influences the healing efficiency of mechanical recovery since the flexural strength of the incline-printed samples is lower than the other two counterparts.

The permeability of the samples after the first healing process was also measured. However, the no water leaked through the healed cracks of any vascular-based self-healing concretes. According to the definition of water tightness [16], the water tightness of all investigated vascular based self-healing concretes is fully recovered. However, the permeability test setup used only with a water head of 0.75m, which could make it difficult to measure low values of flow speed. Therefore, the influence of printing direction of vascular networks on watertightness recovery needs further investigation when using epoxy resin as the healing agent.

4 Conclusions

The experiments presented in this paper show that the printing direction has a great influence on the properties of 3D-printed vascular based self-healing cementitious composites. Two commercial printing materials (PVA and PLA) were used to create the vascular networks. The results show that the dissolution of vertically-printed PVA tube is better than the horizontal counterpart and the vertically-printed PVA tubes in the vascular network are successfully dissolved. Besides, the printing direction influences initial mechanical property as well as the permeability of the cracked specimens with PLA vascular networks. Multiple

healing processes were performed on the PLA vascular based self-healing concrete and good healing efficiency regarding strength recovery and water tightness recovery was obtained. The strength recovery was influenced by the printing direction due to the different crack closure after unloading.

References

1. K. Van Tittelboom, N. De Belie, *Materials (Basel)*. **6**, 2182 (2013)
2. Y. Shields, T. Van Mullem, N. De Belie, K. Van Tittelboom, *Sustain. 2021, Vol. 13, Page 12948*, **13**, 12948 (2021)
3. C. M. Dry, *Cem. Concr. Res.* **30**, 1969 (2000)
4. V. C. Li, Y. M. Lim, Y. W. Chan, *Compos. Part B Eng.* **29**, 819 (1998)
5. P. Minnebo, G. Thierens, G. De Valck, K. Van Tittelboom, N. De Belie, D. Van Hemelrijck, E. Tsangouri, *Materials (Basel)*. **10**, 49 (2017)
6. S. Pareek, A. Oohira, in *Proc. 3rd Int. Conf. Self Heal. Mater.*, Bath, UK, p. Vol. 2729 (2011)
7. S. Sangadji, E. Schlangen, *J. Adv. Concr. Technol.* **10**, 185 (2012)
8. R. E. Davies, A. Jefferson, R. Lark, D. Gardner (2015)
9. K. S. Toohey, N. R. Sottos, J. A. Lewis, J. S. Moore, S. R. White, *Nat. Mater.* **6**, 581(2007)
10. Z. Li, L. R. de Souza, C. Litina, A. E. Markaki, A. Al-Tabbaa, *Mater. Des.* **190**, 108572 (2020)
11. E. Tsangouri, C. Van Loo, Y. Shields, N. De Belie, K. Van Tittelboom, D. G. Aggelis, *Appl. Sci. 2022, Vol. 12, 4821, 12*, 4821 (2022)
12. Z. Wan, Y. Xu, Y. Zhang, S. He, B. Šavija, *Eng. Fract. Mech.* **267**, 108471(2022)
13. Z. Li, L. R. de Souza, C. Litina, A. E. Markaki, A. Al-Tabbaa, *Materials (Basel)*. **12**, 3872 (2019)
14. C. D. Murray, *Proc. Natl. Acad. Sci.* **12**, 207 (1926).
15. Z. Wan, Y. Zhang, Y. Xu, B. Šavija, *Eng. Struct.* (to be published)
16. E. Tziviloglou, V. Wiktor, H. M. Jonkers, E. Schlangen, *Constr. Build. Mater.* **122**, 118 (2016)