

Developing health indicators for composite structures based on a two-stage semi-supervised machine learning model using acoustic emission data

Moradi, M.; Chiachío, Juan; Zarouchas, D.

DOI

[10.7712/150123.9844.451295](https://doi.org/10.7712/150123.9844.451295)

Publication date

2023

Document Version

Final published version

Published in

Proceedings of the 10th ECCOMAS Thematic Conference on Smart Structures and Materials

Citation (APA)

Moradi, M., Chiachío, J., & Zarouchas, D. (2023). Developing health indicators for composite structures based on a two-stage semi-supervised machine learning model using acoustic emission data. In *Proceedings of the 10th ECCOMAS Thematic Conference on Smart Structures and Materials* (Vol. 10, pp. 923-934). <https://doi.org/10.7712/150123.9844.451295>

Important note

To cite this publication, please use the final published version (if applicable). Please check the document version above.

Copyright

Other than for strictly personal use, it is not permitted to download, forward or distribute the text or part of it, without the consent of the author(s) and/or copyright holder(s), unless the work is under an open content license such as Creative Commons.

Takedown policy

Please contact us and provide details if you believe this document breaches copyrights. We will remove access to the work immediately and investigate your claim.

Green Open Access added to TU Delft Institutional Repository

'You share, we take care!' - Taverne project

<https://www.openaccess.nl/en/you-share-we-take-care>

Otherwise as indicated in the copyright section: the publisher is the copyright holder of this work and the author uses the Dutch legislation to make this work public.

DEVELOPING HEALTH INDICATORS FOR COMPOSITE STRUCTURES BASED ON A TWO-STAGE SEMI-SUPERVISED MACHINE LEARNING MODEL USING ACOUSTIC EMISSION DATA

MORTEZA MORADI^{*}, JUAN CHIACHÍO[†] AND DIMITRIOS ZAROUCAS^{*}

^{*} Center of Excellence in Artificial Intelligence for structures, prognostics & health management, Aerospace Engineering Faculty, Delft University of Technology
Kluyverweg 1, Delft, 2629 HS, The Netherlands
e-mail: M.Moradi-1@tudelft.nl

[†] Dept. Structural Mechanics & Hydraulics Engineering, Andalusian Research Institute in Data Science and Computational Intelligence (DaSCI), University of Granada
Granada18001, Spain

Abstract. Composite structures are highly valued for their strength-to-weight ratio, durability, and versatility, making them ideal for a variety of applications, including aerospace, automotive, and infrastructure. However, potential damage scenarios like impact, fatigue, and corrosion can lead to premature failure and pose a threat to safety. This highlights the importance of monitoring composite structures through structural health monitoring (SHM) and prognostics and health management (PHM) to ensure their safe and reliable operation. SHM provides information on the current state of the structure, while PHM predicts its future behavior and determines necessary maintenance. Health indicators (HIs) play a crucial role in both SHM and PHM, providing information on structural health and behavior, but accurate determination of these indicators can be challenging due to the complexity of material behavior and multiple sources of damage in composite structures. In the present work, a model containing a developed adaptive standardization, a dimension reduction sub-model, a time-independent sub-model, and a time-dependent sub-model is introduced to address this challenge. First, the raw data collected by the acoustic emission technique monitoring composite structures under fatigue loading is processed to provide plenty of statistical features. The extracted features are adaptively standardized according to the available data until the current time. Then, the principal component analysis algorithm is employed to reconstruct a few yet highly informative features out of those statistical features. An artificial neural network is used to regress the principal components to the HI that meets the prognostic criteria. Finally, the last sub-model takes into account the time dependency of HI values during fatigue loading. In comparison to other models, the results show superior performance.

Key words: Prognostic and Health Management, Structural Health Monitoring, Intelligent Health Indicator, Artificial Intelligence, Composite Structures, Acoustic Emission.

1 INTRODUCTION

The use of composite structures is increasing in different industries thanks to their desirable mechanical properties such as lightweight and high strength. However, interpreting and predicting their behavior is more challenging than that of isotropic materials such as metals, especially during complex operational loading conditions like compression-compression fatigue loading [1]. In fact, describing the behavior of composite structures with the existing physics-based models has not been completely successful, taking different aspects into account [2, 3]. This becomes even more unpredictable when some uncertain events, such as impacts, happen that may not have already been included in the calculation [4]. With this in mind, the question is how safely to use these structures in sensitive industries such as aviation for a long period of time. The simple and fast answer could be increasing the design (safety) factor, making the structures thicker and the aircraft heavier. However, this solution is not obviously efficient in various terms, including zero emissions, cost, and sustainability. Thus, the prediction of the structure's behavior, especially its remaining useful life (RUL), in such industries not only increases safety and efficiency but also saves time and money regarding maintenance. However, a health indicator (HI) is needed to first represent the damage status of the structure and secondly predict its RUL [5]. The first part, namely diagnosis, can help to interpret the behavior of the structure and its damages, which will be useful to discover the weak points and improve the design. The second part, namely prognosis, can improve safety by predicting the failure time of the component earlier. Diagnosis and prognosis together can significantly improve the decision-making process for maintenance, which is really costly in aviation, in a way that the first one will say what types of actions are needed and the latter one will determine when these actions are taken.

Designing (or discovering) a HI that satisfies the needs for both diagnostics and prognostics is really challenging, and it seems even more difficult for complicated cases such as composite structures. A HI (or damage index) of a structure is always decreasing (or increasing) during operational conditions if no maintenance and self-healing occur. This fact should be induced in the design of a HI and investigated by a metric, namely monotonicity (Mo). When a group of similar structures reach their end-of-life (EoL), their comprehensive HIs should logically and ideally end up at the same value, representing the failure threshold. Unfortunately, HIs at the EoL do not end up with the same value and fluctuate; this deviation can be measured by a metric called prognosability (Pr). Finally, if the HIs for similar structures follow a similar correlation in terms of usage time and have the same pattern, they are more predictable. This similarity in HIs' trends can be measured by the criterion of trendability (Tr) [6-8]. The first two expectations (Mo and Pr) can be considered as facts, while the maximum Tr obviously may not be achievable due to the stochasticity and uncertainty of influential phenomena, including different progressive damage scenarios and loading conditions. Nevertheless, achieving HIs with a high Tr is still a target in order to enhance the RUL prediction accuracy. In the perspective of the prognostics, which is the main target of the current work, a HI should meet these three evaluation criteria, Mo, Pr, and Tr.

Complex time-dependent patterns (e.g., progressive damages in composite laminates) and uncertain events (e.g., a bird strike to an airplane) cannot be taken into account without online

condition monitoring [9], which is termed structural health monitoring (SHM) for the case of structures. Thus, SHM plays an important role in the diagnostics of the structures [10]. An extension of SHM is termed "prognostics and health management (PHM)" technology, which includes RUL prediction and is more comprehensive. Among different SHM techniques, acoustic emission (AE) is one of the most popular and promising ones [11]. The principles of elastic wave dispersion through the structure are the basis for this passive SHM technique, which is highly sensitive to damage initiation and propagation. An AE system continuously gathers signals from sensors attached to the structure. Since these signals are not steady over time due to the nonlinear nature of the physical system in operation, they should be processed and mined over time-windowed intervals. Moreover, interpreting the raw AE data and translating it to the health state of the structure is not straightforward [12]. Thus, feature extraction from the time-windowed AE data can not only take steps towards this purpose but also reduce the capacity needed to carry the massive raw data, which is problematic in long applications like the fatigue loading of structures (reduction from billions to thousands) [13]. It should be noted that in complex applications where there are no pre-confirmed or pre-promising features to select, it is important to first extract as many statistical features as possible from the time and frequency domains of the signals. However, the tremendous features require a more complicated fusion model to construct desirable HIs. To moderate this issue, dimension reduction techniques, ensuring that the variation among features can be kept, result in a simpler HI constructor model.

One of the common characteristics of the prognostics and HI construction models is that they are time-dependent, meaning that the correlation between the historic data from the beginning (often in a healthy state) and the current time should be taken into account to improve the performance of the HI and RUL prediction models. The performance of the HI design model can therefore benefit from taking into account whether or not SHM data are time-dependent.

An AE dataset of composite panels with a single stiffener that were subjected to impact and run-to-failure C-C fatigue loading is examined in the current work [14]. The dataset consists of 201 statistical (time and frequency) features that were drawn from AE data that had been windowed using different lengths and sliding windowing sizes. In the current work, 500 cycles for both length and slide have been selected. The 201 statistical features are first adaptively standardized for each composite panel individually using a new standardization method. Then, using the principal component analysis (PCA) method, 201 features are reduced to 10 features, which are then imported into a multilayer perceptron (MLP) to be regressed to HI labels without taking the time-dependency relationship of the SHM data at various time steps into account. A semi-supervised learning technique is used to train the model using the simulated ideal labels because the true HI labels are not available [15]. With an objective function combining the HIs evaluation criteria and the regression error, the Bayesian optimization algorithm is used to determine the hyperparameters of this time-independent model (TIM). The predicted HI values with TIM, or "1st level HI," are then imported into the next model to take into account the time-dependency from the prior SHM data up to the current time step. But before using this time-dependent model (TDM), the 1st level HIs are resampled based on usage time to have the same length in each batch with the goal of enhancing the TDM section's performance. The performance of the suggested approach is finally confirmed by a comparison of the final outputs

(the 2nd level HIs) alongside the output of TIM in terms of the criteria scores.

2 CRITERIA

To evaluate the quality of a prognostic signature (HI), three confirmed criteria (Mo, Pr, and Tr) are used, which are expressed as follows:

$$Mo = \frac{1}{M} \sum_{j=1}^M \left| \frac{\sum_{i=1}^{N_j} \sum_{p=1, p>i}^{N_j} (t_p - t_i) \cdot \text{sgn}(x(t_p) - x(t_i))}{(N_j - 1) \sum_{i=1}^{N_j} \sum_{k=1, k>i}^{N_j} (t_p - t_i)} \right| \cdot 100\% \quad (1)$$

$$Tr = \min_{j,k} \left| \frac{\text{cov}(x_j, x_k)}{\sigma_{x_j} \sigma_{x_k}} \right|, \quad j, k = 1, 2, \dots, M \quad (2)$$

$$Pr = \exp \left(- \frac{(\text{std}_j x_j(N_j))}{\text{mean}_j(|x_j(1) - x_j(N_j)|)} \right), \quad j = 1, 2, \dots, M \quad (3)$$

where $x(t_p)$ and $x(t_i)$ represent the measurements at the times of t_p and t_i , respectively. Cov is the covariance, where x_j is the vector of measurements on the j^{th} specimen (among M specimens) that has N_j measurements. σ_{x_j} and σ_{x_k} are the standard deviations of x_j and x_k , respectively. The selected metric for Mo in Eq. (1), the so-called Modified Mann-Kendall (MMK), compared to the other versions (Sign and Mann-Kendall), is more robust to noise and also considers the relation of data points with a time gap of more than one unit [13, 16]. All three criteria get a score in the range of [0 – 1], with 1 representing the optimum score for the HIs. After considering all of the above-mentioned criteria, the *Fitness* metric is defined as follows:

$$Fitness = a \times Mo_{HI} + b \times Pr_{HI} + c \times Tr_{HI} \quad (4)$$

which ranges from 0 (minimum quality) to 3 (maximum quality) for the evaluated HIs, assuming that the control constants a, b, and c are 1.

3 SEMI-SUPERVISED CRITERIA-BASED FUSION MODEL

In the present work, a machine learning approach is developed that is based on a combination of a dimension reduction model (PCA), a time-independent model (TIM), and a time-dependent model (TDM) after up-sampling of timeseries in each batch. Since no true value is available as HIs, the ideal HIs labels are simulated in terms of the usage time, and a semi-supervised framework is employed through implicitly implementing the prognostic metrics (Mo, Pr, and Tr) as well as exploiting the given EOL [17]. This framework is categorized based on inductive learning algorithms, termed intrinsically semi-supervised [15], which are improvements to preexisting supervised algorithms that enable labeled and unlabeled data to be used directly to optimize an objective function with components. The overall framework from the raw SHM data to the final HI, including the proposed model, is shown in Figure 1. From the pre-

processing step to the feature extraction step can be found in [13], and the same statistical features extracted from time and frequency domains are used in the current work, which is publicly available [14]. The rest of the framework’s steps, from the adaptive standardization to the TDM, are presented as the main contributions of the current work.

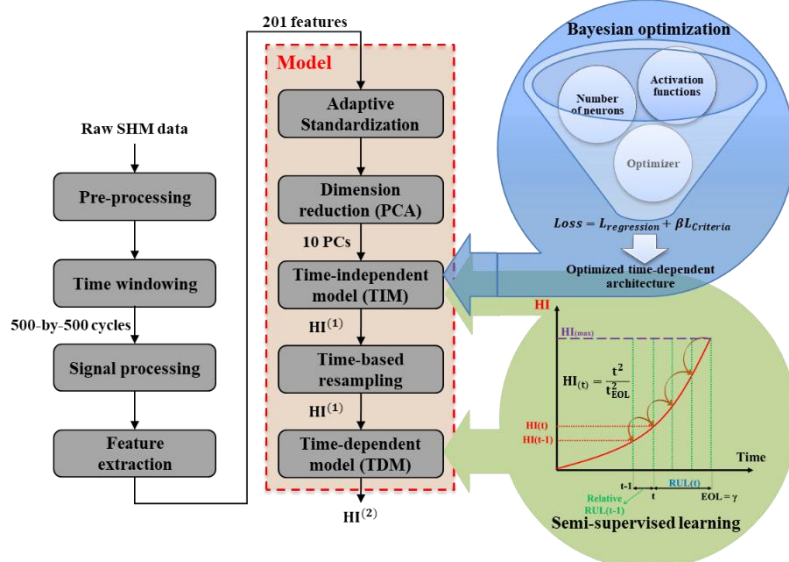

Figure 1: The overall framework from the raw SHM data to the final HI.

3.1 Adaptive standardization

The normalization (referring to max-min normalization) or standardization (referring to zero-mean normalization) processes are the most common and typical step applied to inputs as a pre-processing technique before importing the inputs to a model. These helpful pre-processing techniques are also sometimes used between the hidden layers of a model. However, they should be carefully used in the field of prognostics or other fields with a similar purpose, considering that future data should not be accessible to the model, especially during the training phase. In fact, when the input data are normalized according to the minimum and maximum of the entire trajectory or standardized according to the mean value and the standard deviation of the entire trajectory, the input data distribution is already moved into a known distribution. In this way, the problem has somehow been converted to an interpolation task for the data-driven model, while in reality it is an extrapolation task, which is more challenging for machine learning models. This point is critical for evaluating the prognostic approaches, either the HI’s construction or the RUL prediction models.

The acceptable standardization technique can be done for both training and test data according to the mean value and standard deviation calculated only from the training data [13]. However, this technique may not be helpful to pre-process the new unseen data (validation or test portions) for the prognostics framework, as we also used the same process and observed its misleading effects on the results. As a result, a new adaptive standardization technique is developed in the current work. Assuming that μ_i and σ_i are the mean value and standard deviation of the data $(x_{1:i})$ up to the present (time step t_i), the data are standardized as follows:

$$x_{1:i} = \frac{x_{1:i} - \mu_i}{\sigma_i} \quad (5)$$

$$\mu_i = \frac{\sum_{j=1}^i x_j}{j} \quad (6)$$

$$\sigma_i = \sqrt{\frac{\sum_{j=1}^i (x_j - \mu_i)^2}{j}} \quad (7)$$

This process is performed for the extracted AE features of each composite specimen separately, which is acceptable and applicable from the perspective of the prognostics.

3.2 Dimension reduction

Since the number of extracted features from AE data is high, i.e., 201, which causes more complex subsequent models, they can first be reduced. In this regard, the PCA model, which is a promising dimension reduction technique, is utilized to decrease the number of features from 201 statistical features to 10 principal components (PCs). The percentage of the total variance explained by 10 PCs for twelve composite specimens is listed in Table 1. As can be seen, the minimum variance covered by the first 10 PCs is 86.97% for composite specimen 3. More PCs could be extracted as inputs for the subsequent models, but to keep the models simpler, such a reconstructed variance of AE features is accepted. The PCs for all twelve composite specimens are shown in Figure 2.

Table 1: The percentage of the total variance covered by 10 PCs for different composite specimens.

| Specimen | 1 | 2 | 3 | 4 | 5 | 6 | 7 | 8 | 9 | 10 | 11 | 12 |
|----------------------|-------|-------|-------|-------|-------|-------|-------|-------|-------|-------|-------|-------|
| covered variance (%) | 90.79 | 91.24 | 86.97 | 93.16 | 95.13 | 92.46 | 92.45 | 97.97 | 91.75 | 96.81 | 94.46 | 97.69 |

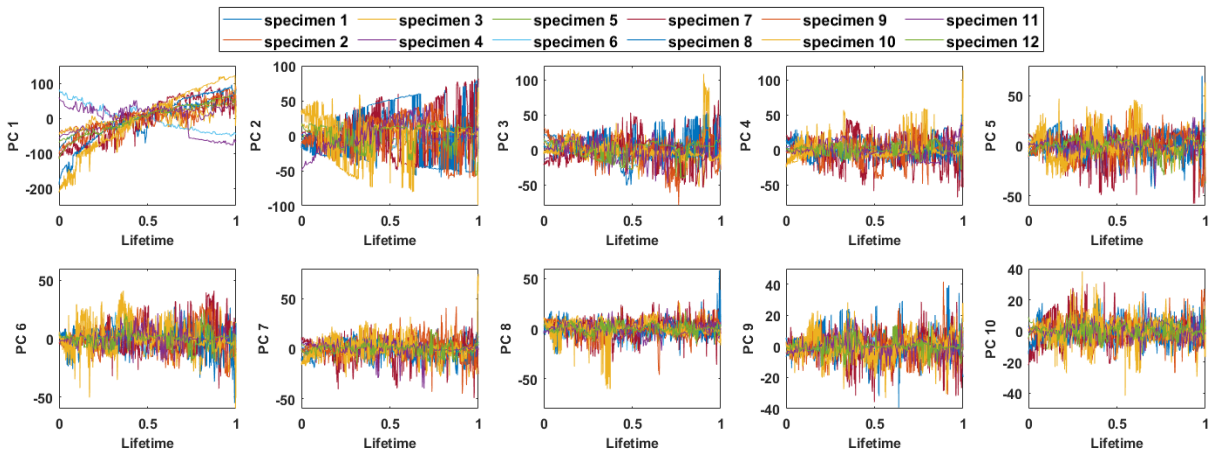

Figure 2: The first 10 PCs extracted from 201 AE features for twelve single-stiffener composite panels.

3.3 Time-independent model (TIM)

In this section, an initial neural network architecture is established first, and the BO algorithm is then employed to optimize the pertinent constructive hyperparameters. Given that only ten features (PCs) remain after the dimension reduction step by PCA, an MLP with a few layers can be a suitable starting point for the regression task, which entails fitting 10 PCs to a value (HI).

3.3.1 Multilayer perceptron (MLP)

To fit the 10 PCs to the ideal simulated HI, an MLP network including 4 layers is designed with a linear transfer function as the output layer. A modified mean absolute error (MMAE) is used as the loss function between predictions and targets:

$$L_{TIM} = (1 - \alpha) \frac{1}{R} \sum_{j=1}^R |T_j - a_j^l| + \alpha \sum_{k=1}^r w_k^2 \quad (8)$$

where R represents the number of responses, T_j and a_j^l denotes target value and the network's output for response j , respectively. α is the regularization parameter to improve generalization by modifying the performance function. Using this performance function leads the neural network to have smaller weights and biases, resulting in a smoother response and less overfitting. α is considered 1 for the current work. Only the training (composite specimens) set is used to train and validate the MLP model, with 30% of the training data used for validation. Although the maximum number of training epochs was set to 1000, the output of the MLP is based on the best validation loss, with the validation check patience set to 10. According to the optimizers and default values in the MATLAB R2022a framework, the other hyperparameters are determined using the BO algorithm.

3.3.2 Bayesian optimization (BO)

The hyperparameters that should be optimized by the BO include training optimizer algorithms as well as each layer's number of neurons and activation function. Three types of optimizing algorithms are regarded as the first optimizable variable (optimizer algorithms), including Levenberg-Marquardt (LM), Bayesian regularization (BR), and resilient backpropagation (RB). The number of neurons in fully connected (FC) layers 1, 2, 3, and 4 has been allocated [1,50], [1,50], [1,50], and [1,10], respectively, based on trial and error. The last optimizable variable is the activation function, which is assigned the same type for all hidden layers and is selected from a categorical space including linear, Rectified Linear Units (ReLU), saturating linear, symmetric saturating linear, hard-limit, symmetric hard-limit, log-sigmoid, hyperbolic tangent sigmoid, Elliot symmetric sigmoid, radial basis, normalized radial basis, triangular basis, inverse, softmax, and competitive according to the MATLAB definition. The BO algorithm was given 100 trials with an exploration ratio of 0.8 in parallel computing to optimize the hyperparameters.

A new objective function for the BO algorithm is introduced in order to consider the HI's evaluation metrics. The BO objective includes two parts: regression loss and criteria loss. The

first one is based on the root-mean-square error (RMSE) between the targets and predictions over only the validation (composite specimens) set. The second loss includes the Mo, Pr, and Tr, which are calculated considering all data sets, including training and validation portions. The relevant equations are as follows:

$$L_{regression} = \frac{RMSE(T_i, a_i^t)}{100} = \frac{\sqrt{\frac{1}{Q} \sum_{i=1}^Q (T_i - a_i^t)^2}}{100} \quad (9)$$

$$L_{criteria} = \frac{3 - Fitness}{3} = \frac{3 - (Mo + Pr + Tr)}{3} \quad (10)$$

$$L_{BO} = L_{regression} + \beta L_{criteria} \quad (11)$$

where β is the importance coefficient of $L_{criteria}$ against $L_{regression}$. $L_{criteria}$ has been normalized based on the maximum fitness score to fall in the range of [0, 1], while $L_{regression}$ has been normalized based on the maximum target value, which is 100. It should be noted that the ideal HI values are simulated in a range from 0 (healthy state) to 100 (failure state).

3.4 Time-based resampling

After the TIM step, the 1st level predicted HI could be considered as a prognostic parameter to import into a prognostic model for predicting RUL. However, the time-dependency between the data has not yet been considered, even though this relationship is a fact according to the physics of the phenomenon. Before designing the time-dependent model, its input data should be resampled in such a way that all sequence input HI(1) (1st level predicted HI) within a batch have the same length. However, the typical padding techniques, such as zero padding, are not appropriate in this case since the HIs values with respect to the percentage of lifetime should be similar. For instance, if the batch size is 2 and the lengths of the HIs are 100 and 1000, the first HI cannot be extended by 900 zero values to have the same length as the second HI. In this case, the HI at the EOL for the first specimen becomes 0, while it should be 100, the same as the second HI. Similarly, the typical interpolation cannot be performed since the correlation between the number of data points in HI and the EOL is not constant or even linear. Sometimes the length of HI for a longer EOL is less than for one with a shorter EOL, as a result of the varying sampling frequency of the AE system depending on the pre-determined amplitude threshold value and uncertain progressive damage in composite panels. With this in mind, a new up-sampling technique called "time-based resampling" is employed in the current research. First, the time vectors of HIs are converted to percent lifespan, i.e., [0%, 100%]. Then, in each batch, the shorter HI vectors (in terms of the number of data points) are up-sampled to equal the longer HI vector's length according to the relevant time vectors. This process is repeated for each batch separately. It should be noted that the size of the batch cannot be equal to the number of all training data sets in this case. Because the TIM will learn only the position of the data regardless of its value, it starts to predict from zero (healthy) at the beginning up to 100 (failure) at the EOL according to the position of the coming data. For instance, for HIs with an equal length of 1000, the TIM model, by using only a bias, will learn that position 1 should

result in a zero value and position 1000 should result in a hundred, without caring about the input value. If a model is trained in this way, the performance for the test set would be significantly low, since the test set should not logically be resampled. Thus, the batch size should be less than the whole training data. In the current study, one composite panel is considered for validation and one for the test, and 10 samples are retained for training. Therefore, the batch size for the TIM could be 2 or 5, of which 2 seems more reasonable. It should be noted that if batch size 1 is chosen, time-based resampling is pointless.

3.5 Time-dependent model (TDM)

To maintain a long-term record of sequential inputs by using the memory, the long short-term memory (LSTM) is a proper candidate that can be considered as one of the main layers of the TDM. The designed architecture for the TIM in the present work can be seen in Figure 3. The LSTM layer has 10 units with initializing zero values for hidden and cell states. After the LSTM layer, a FC layer with one neuron following a ReLU activation layer is utilized. The pseudo-Huber loss function, which is a smooth approximation of the Huber loss function, is used for the regression task. The Huber loss is a function used in robust regression with less sensitivity to outliers than RMSE. The equation for the pseudo-Huber loss function is as follows:

$$L_{TDM} = \delta^2 \left(\sqrt{1 + \left(\frac{T_j - a_j^t}{\delta} \right)^2} - 1 \right) \quad (12)$$

where the steepness at extreme values can be controlled by δ , which is considered 20 in the present work after trial and error.

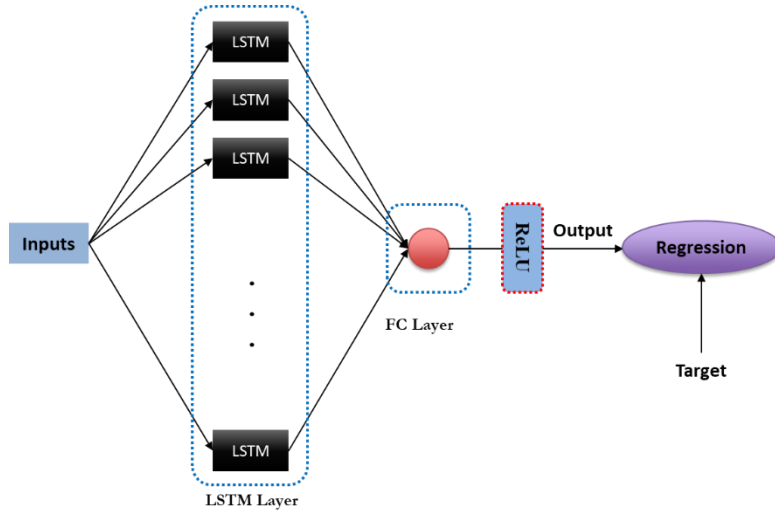

Figure 3: Architecture of the time-dependent model (TDM).

An Adam optimizer was used to learn the TDM, with an initial learning rate of 0.01, a

learning rate drop factor of 0.1, a learning rate drop period of 10, and a gradient threshold of 1, all of which have been selected after trial and error. Despite the fact that the maximum number of training epochs was set to 2000, the network’s output is based on the best validation loss, with the validation check frequency set to 50 iterations (the number of trained batches) and the validation check patience set to 50. As mentioned in the previous section, the batch size of 2 was taken, where no padding is needed since the sequences in each batch are already of equal length.

4 RESULTS AND DISCUSSIONS

Table 2 displays the hyperparameters for the TIM sub-model that have been optimized using BO. The 1st and 2nd level HIs that are outputted after the TIM and TDM sub-models can be seen in Figure 4. It is important to note that specimens 11 and 12 were utilized as validation and test samples, respectively. The error shown in Figure 4 represents the RMSE between the simulated ideal HIs and the constructed (1st and 2nd level) HIs. As shown in the figure, the HI⁽¹⁾s generated by TIM have high fluctuations, while TDM upon TIM produces smooth HI⁽²⁾s. The HI⁽¹⁾s for specimens 6 (training) and 11 (validation) exhibit a decreasing trend, which highlights the limitations of the TIM. On the other hand, the TDM was able to correct the trend for these two specimens. In terms of the behavior of HI⁽²⁾s, there are several (1 to 3) increasing steps observed over the fatigue life, which can be interpreted as different damage states and can contribute to the subsequent prognostic model for RUL prediction.

The evaluation metrics for the constructed HIs are presented in Table 3. Thanks to considering the time-dependency, all the scores for HI⁽²⁾ are higher than those for HI⁽¹⁾. The proposed model not only offers a simpler and faster approach, but it also produces higher *Fitness* scores when compared to state-of-the-art results [17]. Notably, the deep learning model in [17] comprises 193418 learnable parameters, whereas the proposed method has only 1319 learnable parameters (~0.7%), with 828 assigned to TIM and 491 assigned to TDM.

Table 2: The hyperparameters of the TIM optimized by the BO.

| optimizer algorithms | FCL1 | FCL2 | FCL3 | FCL4 | activation function | Objective value (L_{BO}) |
|-------------------------|------|------|------|------|-----------------------------|---------------------------------|
| Bayesian regularization | 7 | 4 | 50 | 9 | symmetric saturating linear | 0.6949 |

Table 3: The HIs’ evaluation metrics for the 1st and 2nd level HIs constructed by TIM and TDM, respectively.

| HIs’ evaluation criteria | TIM (HI ⁽¹⁾) | TIM-TDM (HI ⁽²⁾) | Ref. [17] |
|--------------------------|--------------------------|------------------------------|-----------|
| <i>Mo</i> | 0.93 | 1 | 1 |
| <i>Pr</i> | 0.65 | 0.97 | 0.95 |
| <i>Tr</i> | 0.62 | 0.94 | 0.94 |
| <i>Fitness</i> | 2.21 | 2.91 | 2.89 |

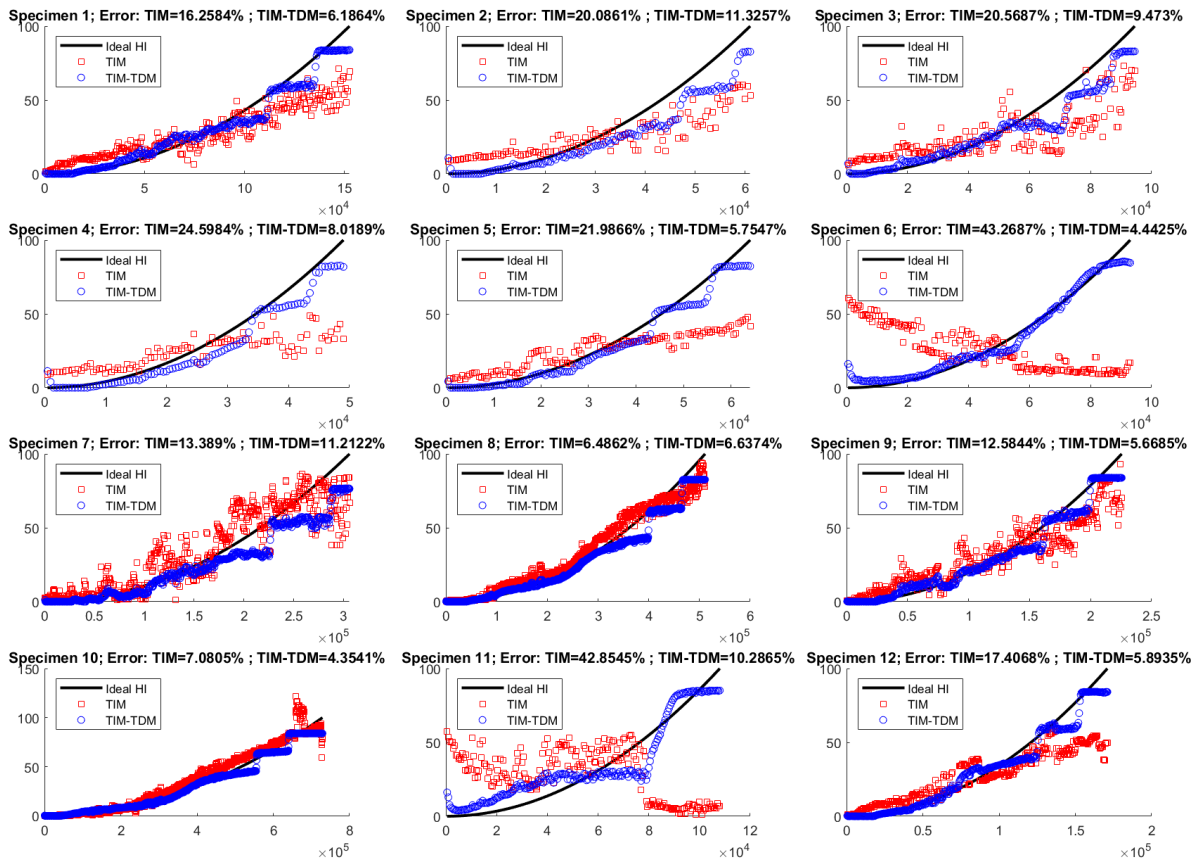

Figure 4: The 1st and 2nd level HIs outputted after the TIM and TDM sub-models.

5 CONCLUSIONS

The study examined an AE dataset of composite panels with a single stiffener subjected to impact and run-to-failure C-C fatigue loading. Using a new standardization method and PCA, the 201 statistical features were reduced to 10 features, which were then imported into an MLP to be regressed to simulated HI labels. The TIM sub-model was optimized using the BO algorithm, and the predicted HI values were imported into the TDM sub-model to enhance its performance. The proposed approach produced higher Fitness score than state-of-the-art results and had much less ($\sim 0.7\%$) learnable parameters, which is much simpler and faster than the deep learning model in the previous study.

REFERENCES

- [1] B. Ameri, M. Moradi, B. Mohammadi, and D. Salimi-Majd, "Investigation of nonlinear post-buckling delamination in curved laminated composite panels via cohesive zone model," *Thin-Walled Structures*, vol. 154, p. 106797, 2020.
- [2] T. Peng, Y. Liu, A. Saxena, and K. Goebel, "In-situ fatigue life prognosis for composite laminates based on stiffness degradation," *Composite Structures*, vol. 132, pp. 155-165, 2015.

- [3] F. Wu and W. Yao, "A fatigue damage model of composite materials," *International Journal of Fatigue*, vol. 32, no. 1, pp. 134-138, 2010.
- [4] C. S. Kumar, M. Fotouhi, M. Saeedifar, and V. Arumugam, "Acoustic emission based investigation on the effect of temperature and hybridization on drop weight impact and post-impact residual strength of hemp and basalt fibres reinforced polymer composite laminates," *Composites Part B: Engineering*, vol. 173, p. 106962, 2019.
- [5] M. Moradi, P. Komninos, R. Benedictus, and D. Zarouchas, "Interpretable neural network with limited weights for constructing simple and explainable HI using SHM data," in *Annual Conference of the PHM Society*, 2022, vol. 14, no. 1.
- [6] J. B. Coble, "Merging data sources to predict remaining useful life—an automated method to identify prognostic parameters," 2010.
- [7] Y. Lei, *Intelligent fault diagnosis and remaining useful life prediction of rotating machinery*. Butterworth-Heinemann, 2016.
- [8] L. Saidi, J. B. Ali, E. Bechhoefer, and M. Benbouzid, "Wind turbine high-speed shaft bearings health prognosis through a spectral Kurtosis-derived indices and SVR," *Applied Acoustics*, vol. 120, pp. 1-8, 2017.
- [9] J. Contreras Lopez, J. Chiachío, A. Saleh, M. Chiachío, and A. Kolios, "A cross-sectoral review of the current and potential maintenance strategies for composite structures," *SN Applied Sciences*, vol. 4, no. 6, p. 180, 2022.
- [10] C. Kralovec and M. Schagerl, "Review of structural health monitoring methods regarding a multi-sensor approach for damage assessment of metal and composite structures," *Sensors*, vol. 20, no. 3, p. 826, 2020.
- [11] M. Saeedifar and D. Zarouchas, "Damage characterization of laminated composites using acoustic emission: A review," *Composites Part B: Engineering*, vol. 195, p. 108039, 2020.
- [12] M. Saeedifar, M. Fotouhi, M. A. Najafabadi, and H. H. Toudeshky, "Prediction of delamination growth in laminated composites using acoustic emission and cohesive zone modeling techniques," *Composite Structures*, vol. 124, pp. 120-127, 2015.
- [13] M. Moradi, A. Broer, J. Chiachío, R. Benedictus, T. H. Loutas, and D. Zarouchas, "Intelligent health indicator construction for prognostics of composite structures utilizing a semi-supervised deep neural network and SHM data," *Engineering Applications of Artificial Intelligence*, vol. 117, p. 105502, 2023.
- [14] M. Moradi, A. Broer, and D. Zarouchas. Acoustic emission dataset of single-stiffener composite panels subjected to impact and run-to-failure fatigue loading [Online]. Available: <https://doi.org/10.17632/ys8r8m7bx2.2>
- [15] J. E. Van Engelen and H. H. Hoos, "A survey on semi-supervised learning," *Machine learning*, vol. 109, no. 2, pp. 373-440, 2020.
- [16] N. Eleftheroglou, "Adaptive prognostics for remaining useful life of composite structures," 2020.
- [17] M. Moradi, A. Broer, J. Chiachío, R. Benedictus, and D. Zarouchas, "Intelligent Health Indicators Based on Semi-supervised Learning Utilizing Acoustic Emission Data," in *European Workshop on Structural Health Monitoring: EWSHM 2022-Volume 3*, 2022, pp. 419-428: Springer.