

## Model Predictive Control of water resources systems

### A review and research agenda

Castelletti, Andrea; Ficchi, Andrea; Cominola, Andrea; Segovia, Pablo; Giuliani, Matteo; Wu, Wenyan; Lucia, Sergio; Ocampo-Martinez, Carlos; De Schutter, Bart; Maestre, José María

**DOI**

[10.1016/j.arcontrol.2023.03.013](https://doi.org/10.1016/j.arcontrol.2023.03.013)

**Publication date**

2023

**Document Version**

Final published version

**Published in**

Annual Reviews in Control

**Citation (APA)**

Castelletti, A., Ficchi, A., Cominola, A., Segovia, P., Giuliani, M., Wu, W., Lucia, S., Ocampo-Martinez, C., De Schutter, B., & Maestre, J. M. (2023). Model Predictive Control of water resources systems: A review and research agenda. *Annual Reviews in Control*, 55, 442-465.  
<https://doi.org/10.1016/j.arcontrol.2023.03.013>

**Important note**

To cite this publication, please use the final published version (if applicable).  
Please check the document version above.

**Copyright**

Other than for strictly personal use, it is not permitted to download, forward or distribute the text or part of it, without the consent of the author(s) and/or copyright holder(s), unless the work is under an open content license such as Creative Commons.

**Takedown policy**

Please contact us and provide details if you believe this document breaches copyrights.  
We will remove access to the work immediately and investigate your claim.

Contents lists available at [ScienceDirect](https://www.sciencedirect.com)

## Annual Reviews in Control

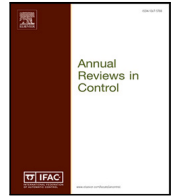
journal homepage: [www.elsevier.com/locate/arcontrol](http://www.elsevier.com/locate/arcontrol)

Full length article



# Model Predictive Control of water resources systems: A review and research agenda

Andrea Castelletti <sup>a,\*</sup>, Andrea Ficchi <sup>a</sup>, Andrea Cominola <sup>b,c</sup>, Pablo Segovia <sup>d</sup>, Matteo Giuliani <sup>a</sup>, Wenyan Wu <sup>e</sup>, Sergio Lucia <sup>f</sup>, Carlos Ocampo-Martinez <sup>g</sup>, Bart De Schutter <sup>h</sup>, José María Maestre <sup>i</sup>

<sup>a</sup> Department of Electronics, Information, and Bioengineering, Politecnico di Milano, Milano, Italy

<sup>b</sup> Chair of Smart Water Networks, Technische Universität Berlin, Berlin, Germany

<sup>c</sup> Einstein Center Digital Future, Berlin, Germany

<sup>d</sup> Department of Maritime and Transport Technology, Delft University of Technology, Delft, The Netherlands

<sup>e</sup> Department of Infrastructure Engineering, University of Melbourne, Parkville, VIC 3010, Australia

<sup>f</sup> Department of Biochemical and Chemical Engineering, TU Dortmund University, Dortmund, Germany

<sup>g</sup> Department of Automatic Control, Universitat Politècnica de Catalunya - BarcelonaTECH, Barcelona, Spain

<sup>h</sup> Delft Center for Systems and Control, Delft University of Technology, Delft, The Netherlands

<sup>i</sup> Department of Systems and Automation Engineering, University of Seville, Spain

## ARTICLE INFO

## Keywords:

Model predictive control  
Water resources  
Water reservoirs  
Open channels  
Urban water networks

## ABSTRACT

Model Predictive Control (MPC) has recently gained increasing interest in the adaptive management of water resources systems due to its capability of incorporating disturbance forecasts into real-time optimal control problems. Yet, related literature is scattered with heterogeneous applications, case-specific problem settings, and results that are hardly generalized and transferable across systems. Here, we systematically review 149 peer-reviewed journal articles published over the last 25 years on MPC applied to water reservoirs, open channels, and urban water networks to identify common trends and open challenges in research and practice. The three water systems we consider are inter-connected, multi-purpose and multi-scale dynamical systems affected by multiple hydro-climatic uncertainties and evolving socioeconomic factors. Our review first identifies four main challenges currently limiting most MPC applications in the water domain: (i) lack of systematic benchmarking of MPC with respect to other control methods; (ii) lack of assessment of the impact of uncertainties on the model-based control; (iii) limited analysis of the impact of diverse forecast types, resolutions, and prediction horizons; (iv) under-consideration of the multi-objective nature of most water resources systems. We then argue that future MPC applications in water resources systems should focus on addressing these four challenges as key priorities for future developments.

## 1. Introduction

Adaptive water resources management is a priority for resilient development and adaptation to increasing hydro-climatic variability and socio-economic transformations (Brears, 2018; Şen, 2021; Stevenson et al., 2022; Zhao & Boll, 2022). Global physical and socio-economic changes add pressure on governments and policy-makers to urgently address water-related multi-sector challenges including energy and food security, human and environmental health, economic development, and climate change mitigation and adaptation (e.g., Global Water Partnership - GWP, 2021; Miralles-Wilhelm, 2022; Srivastava, Mehta, & Naess, 2022). To address these challenges, improve the sustainability and efficiency of water resources management, and adapt to transformative changes, new opportunities may come from adaptive control

techniques and hydro-meteorological forecasts (Abioye et al., 2020; Bwambale, Abagale, & Anornu, 2022; Coelho & Andrade-Campos, 2014; Şen, 2021; Ding, Wang, Li, & Li, 2018; Dobson, Wagener, & Pianosi, 2019; Giuliani, Lamontagne, Reed, & Castelletti, 2021; Wu, Maier, Dandy, Arora, & Castelletti, 2020; Yuan et al., 2019).

Control methods and tools have been used in the water management community to design optimal water resources operations for several decades already, since the 1955 Harvard Water Program (see Reuss (2003) for a historical perspective, the pioneering work by Maass et al. (1962) and the reviews in Castelletti, Pianosi, & Soncini-Sessa, 2008b; Coelho & Andrade-Campos, 2014; Creaco et al., 2019; García et al., 2015; Labadie, 2004; Macian-Sorribes & Pulido-Velazquez, 2020; Malaterre, 1995; Malaterre, Rogers, & Schuurmans, 1998; Mareels

\* Corresponding author.

E-mail address: [andrea.castelletti@polimi.it](mailto:andrea.castelletti@polimi.it) (A. Castelletti).

<https://doi.org/10.1016/j.arcontrol.2023.03.013>

Received 23 December 2022; Accepted 24 March 2023

Available online 11 April 2023

1367-5788/© 2023 The Authors. Published by Elsevier Ltd. This is an open access article under the CC BY-NC-ND license (<http://creativecommons.org/licenses/by-nc-nd/4.0/>).

**List of acronyms**

ADP	Approximate Dynamic Programming
ANN	Artificial Neural Network
CSO	Combined Sewer Overflow
DDP	Deterministic Dynamic Programming
DSS	Decision Support System
EPANET	Environmental Protection Agency Network Evaluation Tool
ESP	Ensemble Streamflow Prediction
FQI	Fitted Q-Iteration
IPCC	Intergovernmental Panel on Climate Change
I	Integrator
ID	Integrator Delay
IDZ	Integrator Delay Zero
IR	Integrator Resonance
ISO	Implicit Stochastic Optimization
ML	Machine Learning
MO	Multi-Objective
MPC	Model Predictive Control
OC	Open Channel
OLFC	Open-Loop Feedback Control
PID	Proportional–Integral–Derivative
POLFC	Partial Open-Loop Feedback Control
PRISMA	Preferred Reporting Items for Systematic Reviews and Meta-Analyses
SDP	Stochastic Dynamic Programming
SWMM	Storm Water Management Model
SIC <sup>2</sup>	Simulation and Integration of Control for Canals
SOP	Standard Operating Procedure
SSDP	Sampling Stochastic Dynamic Programming
TB-MPC	Tree-Based Model Predictive Control
UWN	Urban Water Networks
WR	Water Reservoirs

et al., 2005; Van Der Werf, Kapelan, & Langeveld, 2022; Yeh, 1985). Yet, this is still a very active research field, as water systems are uncertain dynamic systems with challenging features that make the use of optimal control tools particularly complex. First, water systems' disturbances and related risks are ever-changing, as the variability induced by changing hydro-climatic conditions has been expanding in recent decades (e.g., Hall et al., 2014; Sreeparvathy & Srinivas, 2022), alongside the frequency and intensity of extreme events that are being exacerbated with climate change (Gründemann, van de Giesen, Brunner, & van der Ent, 2022; IPCC, 2021; Stevenson et al., 2022; Trenberth et al., 2014). Second, human pressure on water resources has been augmenting with population and socio-economic growth, leading to increased water and energy demands at the global scale (e.g., Boretti & Rosa, 2019; van Ruijven, De Cian, & Sue Wing, 2019; Wu, Maier, Dandy, Arora, & Castelletti, 2020). This, in turn, has shifted decision makers' preferences and risk perception (e.g., Giuliani et al., 2021; Poff et al., 2016). Third, water systems usually serve multiple stakeholders with often conflicting and time-evolving objectives (Soncini-Sessa, Castelletti, & Weber, 2007), which makes the exploration of trade-offs essential (e.g., Reed, Hadka, Herman, Kasprzyk, & Kollat, 2013).

The advantages of using real-time adaptive model-based control techniques are evident in the context of hydro-climatic and socio-economic changes, as the use of forecasts unlocks the control potential to anticipate and, therefore, adapt to changes in the system's characteristics and disturbances. These approaches can be grouped under the umbrella of Model Predictive Control (MPC) (Bertsekas, 2005;

Scattolini, 2009), which is a popular approach, mostly well-established for industrial applications (e.g., Forbes, Patwardhan, Hamadah, & Gopaluni, 2015; Qin & Badgwell, 2000; Schwenzer, Ay, Bergs, & Abel, 2021) yet attracting increasing attention from the water systems community (e.g., Giuliani et al., 2021) due to recent advances in monitoring and forecasting systems and increasing computational capabilities (e.g., Wu, Emerton et al., 2020). Hydro-meteorological forecasts have constantly been improving in quality and accessibility over the last few decades (e.g., Buizza, 2019; Wu, Emerton et al., 2020). Similarly, hydrological and water systems' models have been substantially refined in recent years, allowing both the representation of physical processes at the highest resolution (e.g., Bierkens et al., 2015; Nair, McManamay, Derolph, & Allen-Dumas, 2020) and the efficient emulation of high-fidelity models via surrogate models based on machine learning techniques (e.g., Huang, Ma, Ma, Huangfu, & He, 2021; Miro et al., 2021; Wu, Dandy, & Maier, 2014). Today, it is possible to assimilate earth observations and operational forecasts in real-time and run optimization and simulation models within a reasonable time thanks to recent technological advances (Baardman et al., 2022; Blair et al., 2019; Camporese & Girotto, 2022; Creaco et al., 2019).

In this context, we believe that a review of MPC applications to water management problems is timely and important to stimulate reflections on MPC benefits and challenges in the water sector and set the path for further research and practice developments. While previous reviews focused on discussing the use of different optimal control methods in specific water systems (e.g., water reservoirs), here we contribute a comprehensive analysis of the most recent advancements in MPC for different types of water systems. The heterogeneous features of these systems introduce distinct challenges to optimal control techniques and often require diverse MPC approaches. In this review, we focus on three key types of interconnected water systems designed and operated to store, convey, and distribute water for human and environmental needs as well as to manage sewer and drainage flow at the basin to urban scales: water reservoirs, open channels, and urban water networks. To build our comprehensive review of 149 peer-reviewed journal articles, we follow an automatic search procedure and then refine the paper selection using a set of eligibility criteria, as detailed in the Methods.

The Methods section first recalls the MPC methods used for water systems' operations. Then, the three types of water systems within the scope of this review are introduced, explaining why these systems are relevant and detailing the models used in the MPC applications. The Results Section then provides a detailed summary of the reviewed papers across the three types of water systems. Finally, the Discussion and Conclusions Sections summarize the limitations and merits of the applications reviewed and highlight the most urgent needs for future developments.

## 2. Methods

### 2.1. Model predictive control

Model Predictive Control is a control strategy based on the sequential, online resolution of multiple open-loop control problems defined over a finite, receding time horizon (Bertsekas, 2005). At each time step, the resolution of an MPC problem yields a sequence of optimal control actions (i.e., the releases for reservoirs, gate openings for channels, etc.) over the future horizon  $[t, t+h]$ , given a predicted trajectory of the disturbances over the same horizon. The optimization is generally formulated considering a single objective; when the problem involves multiple objectives (e.g., water supply, hydropower production, flood control, environmental protection, irrigation, transport, etc.), these are generally aggregated using a scalarization function (e.g., weighted combination) or via the lexicographic goal programming technique in cases where there is a clear hierarchy of priorities across the objectives (e.g., Horvath et al., 2022). The online optimization scheme is reiterated

forward in time over a receding horizon during the operational life of the system. After each optimization, only the first control action of the optimized control sequence is actuated, before reiterating the optimization at the next time step. Through this reiteration of the model-based optimization, MPC determines the control law implicitly in a closed-loop form, as it computes the optimal control action at each time step  $t$  based on the observed state of the system ( $\mathbf{x}_t$ ). The current state of the system can be directly observed in most of the cases for the water systems considered in this review. A state estimator is needed otherwise.

MPC requires a model of the system (see Section 2.2), also known as *internal* or *prediction* model, to predict the effect of control actions on the controlled system's dynamics, and to determine the set of actions that yield the optimal performance with respect to the considered objectives subject to physical and operational constraints. The choice of the model plays a major role in the performance yielded by the MPC. The flexibility of the direct use of any models available for the systems to be controlled is one of the main advantages of this approach, particularly in terms of controlling highly non-linear systems. The requirement for computational efficiency is the main factor that can limit the use of fully physically-based models of large-scale complex water systems like urban water networks, for which reduced-order data-driven models can be developed to be used in MPC (see Section 3.3). The flexibility in working with (nonlinear) constraints is another advantage of MPC compared to other control methods. And this advantage is particularly relevant for water systems, as explicit physical constraints (with nonlinearities), like limits of actuators, or legal constraints, like a minimum release from reservoirs, are often required.

Another advantage of MPC with respect to other control approaches is the mitigation of the curse of 'dimensionality' (Bellman, 1957) that limits the applicability of Dynamic Programming family methods to large water systems because of the challenges associated with the computation of the value functions for increasing dimensions of state and control vectors. Moreover, the use of real-time information and probabilistic/ensemble forecasts in the optimization process allows MPC to adapt to evolving external conditions and mitigate the impacts of uncertain extreme events.

Different configurations of MPC exist depending on how they handle the control of multiple actuators in large-scale systems (centralized, decentralized, or distributed MPC), the parameter estimation problem (adaptive or non-adaptive MPC), and the uncertainty in disturbance forecasts (deterministic or robust and stochastic MPC; see Sections 2.1.1 and 2.1.2).

A centralized MPC configuration assumes that a single controller processes measurements from all sensors/gauges and determines optimal actions to be applied by all actuators. However, water systems are usually spread over large, often transboundary regions, and several water boards can be involved in their management. In such large systems, centralized management may become unfeasible or computationally cumbersome, and may also be undesirable with regard to system reliability, scalability, and responsiveness. Thus, multi-agent control, whereby the control effort is divided among local agents (also referred to as controllers), each in charge of part of the overall system, emerges as a possible way to circumvent the drawbacks arising from centralized implementations. Two main criteria by which to classify multi-agent control approaches are the existence of communication links and hierarchy among local controllers. On the one hand, an approach is said to be decentralized if interactions among local controllers are neglected, and distributed if communication links among local controllers are enabled for the sake of improved overall performance, although at the expense of increased computation times. On the other hand, an approach is said to be single-level if all local controllers are at the same hierarchical level, and multi-level if a subset of local controllers has ascendancy over the rest.

Regarding the problem of reducing model uncertainties, in standard (non-adaptive) MPC, the model used for prediction is often assumed

to be accurate and fixed in time, while only its state is updated. However, by using a fixed model parameterization the changing uncertainties within the system are not taken into account, which can reduce the MPC performance. In contrast, in adaptive MPC, the model parameters can be updated online by using available measurements, and the estimation problem is addressed by including a parameter estimation procedure as part of the control strategy. The control action is then calculated not only based on the estimated current state but also on the updated model, which can help reduce the dynamic model uncertainties affecting MPC (Lemos, Machado, Nogueira, Rato, & Rijo, 2009).

### 2.1.1. Deterministic MPC

In cases where a single deterministic prediction of the systems' disturbances is available, the formulation of the (single-objective) MPC problem over the prediction horizon ( $h$ ), to be solved at each control time step, is as follows:

$$\min_{u_t, \dots, u_{t+h}} \sum_{\tau=t}^{t+h-1} g_{\tau}(\mathbf{x}_{\tau}, \mathbf{u}_{\tau}, \hat{\mathbf{e}}_{\tau+1}) + g_{t+h}(\mathbf{x}_{t+h}) \quad (1)$$

subject to:

$$\mathbf{x}_{\tau+1} = f_{\tau}(\mathbf{x}_{\tau}, \mathbf{u}_{\tau}, \hat{\mathbf{e}}_{\tau+1}) \quad (2)$$

$$c(\mathbf{x}_{\tau}, \mathbf{u}_{\tau}, \hat{\mathbf{e}}_{\tau+1}) \leq 0 \quad (3)$$

$$\hat{\mathbf{e}}_{\tau+1} \text{ given for } \tau = t, \dots, t+h-1 \quad (4)$$

$$\mathbf{x}_t \text{ given} \quad (5)$$

where:  $\mathbf{x}_{\tau}$  is the state of the system at time step  $\tau$  (e.g., the reservoir storage, the water level in channels, and the state of other dynamical components);  $\mathbf{u}_{\tau}$  is the control vector including all control actions for the actuators (e.g., gates or pumps);  $\hat{\mathbf{e}}_{\tau+1}$  is the deterministic forecast of the system's disturbances provided by a prediction model for each time step  $\tau$  over the prediction horizon  $[t+1, t+h]$ ;  $g_{\tau}(\cdot)$  is a time-separable cost function associated with the transition from time step  $\tau$  to  $\tau+1$ ;  $g_{t+h}(\cdot)$  is a penalty function associated with the final state ( $\mathbf{x}_{t+h}$ ) that represents the future costs beyond the prediction horizon. It should be noted that the control horizon, i.e. the time span for which the control inputs are allowed to vary, can be shorter than the prediction horizon, though often they are assumed to be equal as in Eq. (1).

The optimal control problem (1) is subject to the dynamic constraints provided by the state transition function (Eq. (2)) along with different types of physical constraints (e.g., limits of actuators) and operational/legal ones (e.g., minimum environmental flows) that can be expressed as (non linear) inequality constraints (Eq. (3)).

### 2.1.2. Robust and stochastic MPC

One of the limitations of Problem (1) is that it requires the availability of the sequence of future system disturbances  $\{\hat{\mathbf{e}}_{t+1}^{t+h}$ , which is unrealistic to expect to be perfect in many practical situations. To deal with this issue, the MPC framework includes strategies that handle uncertainties in a robust manner via worst-case formulations, e.g., min-max and robust MPC. While these methods guarantee the satisfaction of the problem constraints as long as some assumptions are satisfied (mainly, that disturbances are bounded), they also generally lead to very conservative control policies because a worst-case scenario approach is followed. To remedy this situation, stochastic MPC approaches exploit the characterization of the forecasted uncertainties, to obtain a trade-off between closed-loop constraint satisfaction and performance. Stochastic MPC approaches typically employ so-called *chance constraints*, i.e., constraints that should be satisfied with a predefined probability level (Mesbah, 2016). Thus, occasional violations of the



constraints might occur, but system performance will be increased during normal system operation because the controller will be allowed to work closer to the constraints in comparison to worst-case approaches.

Here, we propose a classification of existing robust and stochastic MPC approaches used in the water systems literature so far into two categories, based on the way the knowledge of the probability distribution function (pdf) of the disturbances is implemented into the optimization problem: (i) explicit robust and stochastic approaches, that use the explicit information on the pdf, and (ii) implicit approaches, that rely on a set of scenarios (or *ensemble forecasts*) which encode information about the disturbance evolution and its uncertainty in an implicit manner.

- (i) Explicit approaches, require an explicit (probabilistic) characterization of the disturbance behaviour. A classical strategy to deal with uncertainty explicitly is the use of *Open-loop feedback control* (OLFC), as introduced by Bertsekas (1976). This approach presents the future disturbances according to their probability distribution and computes the objectives through a function to filter the disturbances (e.g., expected value). The OLFC performance can be improved by adopting a partial open-loop feedback control (POLFC) formulation (e.g., Castelletti, Pianosi, & Soncini-Sessa, 2008a; Pianosi & Soncini-Sessa, 2009), which explicitly assumes that in the future the state of the system will be measured and a new problem will be reformulated. The POLFC problem, therefore, computes at each time step the optimal release decision for the first time step reflecting first-step uncertainty and the optimal operating policy for the following time steps.
- (ii) Implicit approaches rely on the use of a set of scenarios of the disturbances. The set of scenarios can be either built using data from previous realizations or using real-time probabilistic forecasts. A classical implicit approach that uses scenarios in MPC is the *Scenario-based MPC* which allows optimizing the system behaviour for several disturbance realizations. This approach has been generalized in Calafiore and Campi (2006), Calafiore and Fagiano (2013a, 2013b), and has been applied to water systems in Tian et al. (2019), Tian, Negenborn et al. (2017b), van Overloop, Weijs, and Dijkstra (2008), Velarde, Tian, Sadowska, and Maestre (2019). An interesting feature of this approach is that multiple models can be considered, thus allowing to consider model uncertainty in addition to disturbance uncertainty. The scenario-based MPC approach can be extended via the *Tree-based MPC* (TB-MPC) formulation to provide the controller with enhanced closed-loop control capabilities so that it can adapt to future events, as uncertainty is resolved via bifurcation points along the prediction horizon, as first applied to water systems in Raso, Schwanenberg, van de Giesen, and van Overloop (2014). Implicit approaches are particularly relevant for water systems as the forecasts are often provided in the form of an ensemble of multiple time series, usually generated by running the forecast model multiple times with perturbed initial conditions or using multiple models. Given their capacity to account for the inherent forecast uncertainty, ensemble forecasts have become a standard in hydro-meteorological forecasting (Buizza, 2019; Gneiting & Raftery, 2005; Zhao, Wang, Wu, & Yang, 2021). This ensemble is then transformed into a tree where similar ensemble members are bundled together into one trajectory (branch) up to the point when some of them start to significantly diverge from the others. The tree structure is then used to optimize a *control tree* defining a distinct control sequence for each branch. Control sequences are constrained to be the same up to the time when two ensemble members diverge. Examples of applications of TB-MPC can be found in Ficchi et al. (2016), Maestre, Raso, van Overloop, and De Schutter (2013), Raso et al. (2014), Uysal, Alvarado-Montero, Schwanenberg and Sensoy (2018a).

Explicit knowledge about the disturbance (pdf) might be available and can be used to build a set of scenarios for implicit approaches, such as multi-scenario MPC or TB-MPC, so as to achieve approximate robust MPC strategies (Lucia, Finkler, & Engell, 2013). Alternatively, one may proceed the other way around, by using historical data (e.g., previous realizations of the disturbances or reforecasts) to generate an explicit model (possibly with some limitations) and use that in explicit stochastic approaches.

Finally, stochastic approaches can be considered robust as well if very strict requirements are imposed regarding the probability of closed-loop constraint violation. As the imposed probability of constraint violation tends to zero, the controller becomes more and more robust as it needs to increase the safety margin with respect to the problem constraints. For this reason, there are some articles in the literature that present stochastic approaches from a robustness viewpoint (Chen et al., 2021; Chen & You, 2021; Shang, Chen, Stroock, & You, 2020).

## 2.2. Models for water systems applications

This section provides an overview of the models used for representing the different water systems considered in this review, namely water reservoirs, open channels, and urban water networks. It is worth mentioning that despite we illustrate and discuss these systems separately, they are often interconnected with water reservoirs feeding either open channels and/or urban water networks.

### 2.2.1. Water reservoirs

A water reservoir is a regulated storage or lake, controlled by a dam that either blocks the flow of a watercourse that is drained from upstream catchments (in-stream reservoir) or creates a retention basin collecting water supplied by an adjoining stream, a canal, pipeline or aqueduct (off-stream). Reservoirs can be part of networks of different levels of complexity, with two or more reservoirs in parallel or in series (see Fig. 1 for a schematic representation), connected with water users via natural or artificial canals.

Reservoirs are usually multi-purpose systems, serving power plants, irrigation districts, urban and industrial water users, as well as contributing to other targets like flood control, environmental management, navigation, water quality, etc. Traditionally, reservoir control is implemented by a human operator that can act based on static rule curves or control actions suggested by a Decision Support System (DSS) in real-time. Since the control time step is discrete, the model for a reservoir is typically written in time-discrete form too, even though the physical processes involved in the system are time-continuous. The control time step varies based on the type of systems and objectives, with control frequencies typically ranging from hourly or daily for smaller systems and for flood control or hydropower generation, to monthly for large systems and for water supply objectives. The generic model for a system of  $N$  reservoirs is based on the mass-balance equation describing the dynamics of the water storage at each reservoir  $j$  as:

$$x_{t+1}^j = x_t^j + q_{t+1}^j - r_{t+1}^j \quad (6)$$

where:  $x_t^j$  is the state of reservoir  $j$  at time step  $t$ , i.e., the reservoir storage;  $q_{t+1}^j$  is the net inflow volume (i.e., inflow and direct precipitation minus evaporation and seepage losses) from time step  $t$  to  $t+1$ ;  $r_{t+1}^j$  is the actual release from the reservoir in the same time interval. In the notation in Eq. (6), the time subscript of each variable indicates the time instant when the value is deterministically known. The reservoir storage is measured at time step  $t$  and thus is denoted as  $x_t^j$ , while the net inflow and the actual release are denoted as  $q_{t+1}^j$  and  $r_{t+1}^j$ , respectively because they can be known only at the end of the time interval. For multi-reservoir systems, the global model is obtained by aggregating the models of the  $N$  reservoirs that compose it, i.e., all the variables in Eq. (6) become vectors (e.g.,  $\mathbf{x}_t, \mathbf{q}_{t+1}$ ) and the network

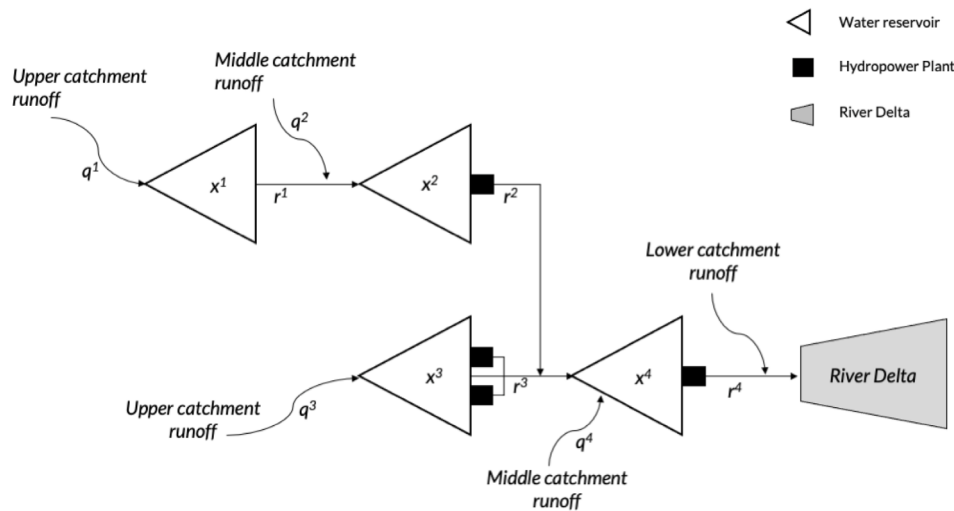

Fig. 1. Schematic representation of a multi-reservoir network. Source: Adapted from the Zambezi river system's scheme reported in Giuliani and Castelletti (2013).

topology can be represented by an incidence matrix (Giuliani et al., 2021).

The actual release  $r_{t+1}^j$  is a function of the control variable  $u_t^j$  (i.e., the release decision at time step  $t$ ), of the storage  $x_t^j$  and of the net inflow  $q_{t+1}^j$ :

$$r_{t+1}^j = R_t^j(x_t^j, u_t^j, q_{t+1}^j) \quad (7)$$

where the function  $R_t^j(\cdot)$  is called the release function and it is a nonlinear function, which binds the actual release within a range of physical acceptability. The range is defined by the minimum and maximum releases that would occur from time step  $t$  to  $t + 1$  by keeping all the sluice gates completely closed and open, respectively (Castelletti et al., 2008b). Thus, the release function allows for the inclusion of physical constraints on reservoir storage and release into the model. The actual release may differ from the control decision when the available water is not sufficient to realize the decision or when a spill takes place. The release function is inherently stochastic because between the time step  $t$  at which the release decision is taken and the time step  $t + 1$  at which the control action is completed, the uncertain net inflow  $q_{t+1}^j$  affects the reservoir storage.

The net inflow  $q_{t+1}^j$  is an aggregation of several hydro-meteorological contributions including upstream and lateral flows from tributaries and runoff, direct precipitation over the reservoir minus evaporation and infiltration losses. The net inflow is often modelled as a system disturbance (i.e.,  $q_{t+1}^j = \varepsilon_{t+1}^j$ ), aggregating multiple sources of uncertainty, though its contributions can also be separately modelled as distinct disturbances. On the other hand, the hydrologic processes contributing to the net inflow can be represented using dynamic hydrological models of different types, from conceptual to physically-based, lumped or spatially distributed, deterministic or stochastic models. Data-driven alternatives or simple statistical models are often preferred because of their computational efficiency (e.g., Wang, Chau, Cheng, & Qiu, 2009) and, recently, efforts are being made to move towards hybrid models (a combination of pure data-driven and process-based models) that can be more interpretable by users (e.g., Chakraborty, Başağaoğlu, & Winterle, 2021). These models can be used to provide a set of deterministic or stochastic forecasts of the disturbance, that can be issued before every control time step and used in an optimal control problem.

### 2.2.2. Open channels

Open-channel systems are large-scale networked systems that consist of natural rivers and artificial canals and serve multiple purposes.

As part of the integrated urban water management cycle, open-channel systems can be used to convey treated water to consumer areas, which may then be supplied to consumers (using pressurized pipeline networks) or used for irrigation purposes. Open-channel systems can also be employed for freight and passenger transportation, provided that water depth and width are sufficient. Moreover, the watercourse should not be interrupted too frequently by elements that must be avoided, e.g., reefs, rocks and sandbanks, and bridges should have sufficient clearance. Although not strictly in the scope of this paper, it is interesting to note that research on inland waterborne transport is attracting increasing attention, as it is one of the most environmentally friendly and cost-effective transport modes. A schematic representation of an open-channel system is given in Fig. 2, which shows its main constitutive elements. On the one hand, canals are stretches of the watercourse bounded between two control structures. On the other hand, actuators are hydraulic infrastructure, e.g., gates, weirs and dams, available for water control purposes (see examples above). Finally, nodes represent canal junctions, i.e., locations wherein a stream flows into or branches off from the main stream (these are known as tributary and distributary, respectively).

Open-channel dynamics are most accurately described by the Saint-Venant equations, a set of coupled nonlinear partial differential equations that can be formulated as follows (Litrico & Fromion, 2009):

$$\frac{\partial A(l, t)}{\partial t} + \frac{\partial Q(l, t)}{\partial l} = 0, \quad (8a)$$

$$\frac{\partial Q(l, t)}{\partial t} + \frac{\partial}{\partial l} \left( \frac{Q^2(l, t)}{A(l, t)} \right) + gA(l, t) \left( \frac{\partial Y(l, t)}{\partial l} + S_f(l, t) - S_b(l) \right) = 0. \quad (8b)$$

Eqs. (8a) and (8b) represent the mass and momentum conservation equations, respectively, the latter comprising inertia, advection, gravitational force and friction force terms. Moreover,  $l$  is the longitudinal abscissa (continuous independent variable),  $t$  is the time (continuous variable),  $A(l, t)$  is the wetted area [ $\text{m}^2$ ],  $Q(l, t)$  is the discharge [ $\text{m}^3/\text{s}$ ] across section  $A$ ,  $V(l, t) = Q(l, t)/A(l, t)$  is the average velocity [ $\text{m}/\text{s}$ ] in section  $A$ ,  $Y(l, t)$  is the water depth [ $\text{m}$ ],  $S_f(l, t)$  is the friction slope [ $\text{m}/\text{m}$ ],  $S_b(l)$  is the bed slope [ $\text{m}/\text{m}$ ] and  $g$  is the gravitational acceleration [ $\text{m}/\text{s}^2$ ].

Eq. (8) must be completed with initial and boundary conditions. On the one hand, the initial condition is given in terms of  $(Q(x, 0), Y(x, 0))$ , for all  $x \in [0, L]$ , where  $L$  is the length of the canal. On the other hand, boundary conditions must be chosen depending on flow characteristics: subcritical flow requires an upstream and a downstream condition; supercritical flow requires two upstream conditions; and

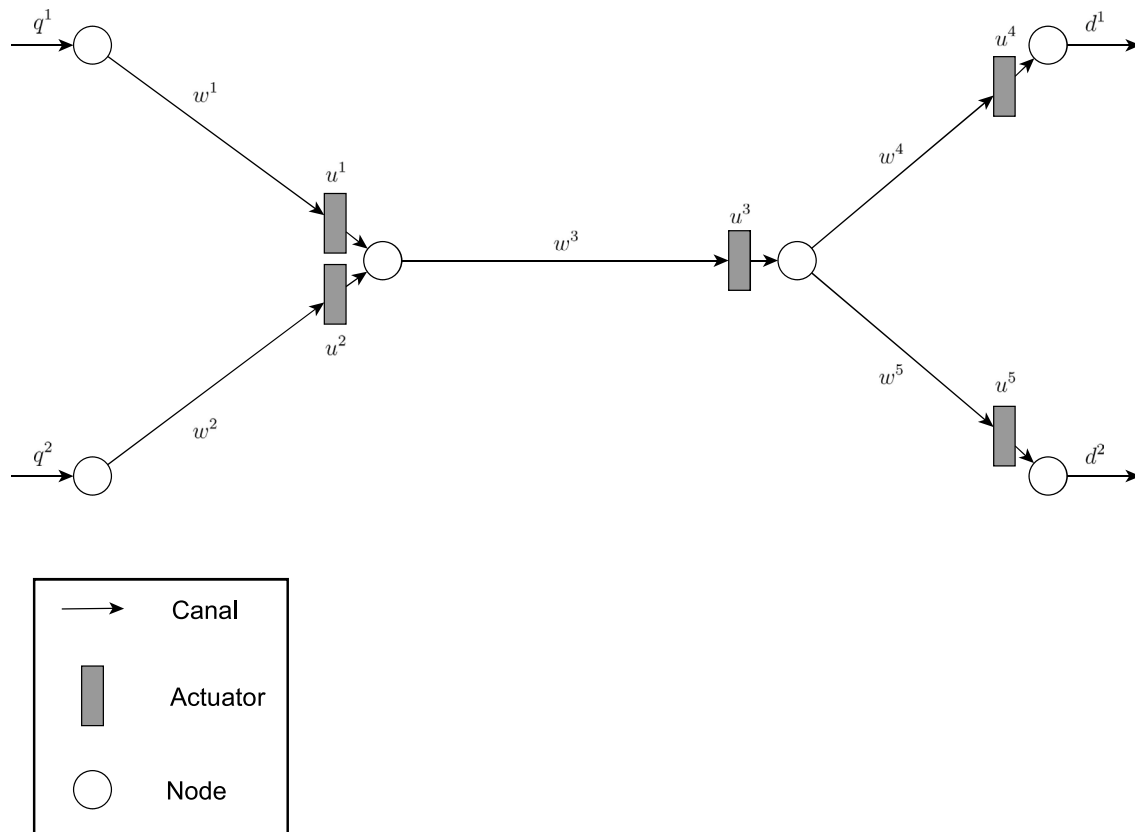

Fig. 2. Schematic representation of an open-channel system.

intermediate situations require to specify one, two, or three conditions, depending on the situation (Litrico & Fromion, 2009). Furthermore, available measurements and controls must be specified. It is typically the case in practical situations that available measurements and controls are boundary water levels and gate openings, respectively (Litrico & Fromion, 2009).

Because of their accuracy, the Saint-Venant equations constitute the basis of state-of-the-art simulation software, e.g., SOBEK<sup>1</sup> and SIC<sup>2</sup>.<sup>2</sup> However, they are demanding in terms of computational resources and provide too much information for applications such as controlling average water levels, two facts that render their direct use impractical for control purposes (hence the variables in (8) are not directly connected with the notation introduced in Fig. 2). For this reason, the use of alternative and simpler models as prediction models (i.e., internal MPC models) is commonly encountered in the literature. These simplified models generally compensate the loss of precision with a significant reduction of the computational burden, which in turn allows to use more elaborated formulations within the MPC framework. Several classes of simplified models have been developed:

- Some models are obtained directly from the Saint-Venant equations, discretizing the system in space (e.g., using a staggered grid) and linearizing. The kind of discretization method employed plays a crucial role in the stability of the obtained model. On the one hand, certain time-implicit methods yield stable models regardless of the step size chosen, even for nonlinear hyperbolic systems (Hirsch, 2007). On the other hand, the stability of explicit discretization methods depends on the discretization step size (Conde, Quijano, & Ocampo-Martinez, 2021).

- Other models are based on strong mechanistic simplifications of the behaviour of the canal dynamics:

- One of the first proposals was the *Integrator Delay* (ID) model (Schuurmans, Bosgra, & Brouwer, 1995; Schuurmans, Clemmens, Dijkstra, Hof, & Brouwer, 1999), an approximation model for flow in an open channel with a backwater effect. The integrator term captures the canal volume change according to the water level variation, and the time delay indicates the required time for a disturbance generated at one end of the canal to have an effect at the other end. It is worth noting that some authors simplify the ID model even further, considering only the integrator term (I), thus assuming that the canal behaves like a reservoir.
- A modification to the ID model was proposed by Litrico and Fromion (2004) to represent the high-frequency phenomena and thus describe a canal in any flow condition. This new model, which features a zero in the transfer function to represent the direct influence of the discharge on the water level in high frequencies, is known as the *Integrator Delay Zero* (IDZ) model.
- The *Integrator Resonance* (IR) model was proposed by van Overloop, Miltenburg et al. (2010), to characterize the effect of reflecting waves on the water levels, which dominate the behaviour of the short and deep open-channel flow.

- System identification techniques have also been employed for the purpose of open-channel modelling. In particular, black-box models, which do not make use of any physical insight, have proven to perform well (Rivas-Pérez, Feliu-Batlle, Castillo-García, & Linares-Sáez, 2014; Weyer, 2001).

The common feature shared by the different simplified models is the connection between discharges and water levels. However, some

<sup>1</sup> <https://www.deltares.nl/en/software/sobek/>

<sup>2</sup> <http://sic.g-eau.net>

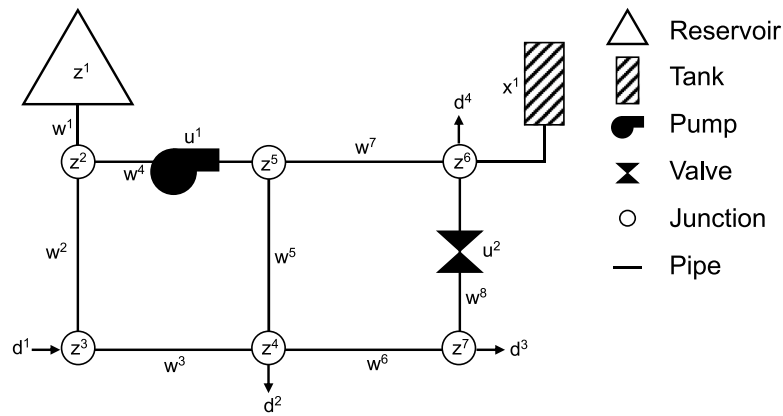

Fig. 3. Schematic representation of a water distribution network. Source: Adapted from the Epanet 2: user manual (Rossman et al., 2000).

of these models are formulated using continuous time input–output representations (e.g., ID, IDZ and IR), and must be discretized for implementation purposes. On the other hand, models with full space–time discretization are directly described in discrete-time state–space form.

With some minor adjustments, all these models can be framed within the more general control-oriented model given below:

$$x_{t+1} = F(x_t, u_t, w_t, d_t), \tag{9a}$$

$$0 = G(x_t, u_t, w_t, d_t). \tag{9b}$$

The variables used in Eq. (9) follow the notation introduced in Fig. 2, and their meaning is as follows: the vector of states  $x_t$  contains the water levels (and possibly other terms, depending on the simplified model that is employed),  $u_t$  denotes the vector of control inputs (e.g., actuator flow or position setpoints; for an exhaustive list of control variables see Section 3.2),  $w_t$  represents the vector of uncontrollable flows due to environmental phenomena (e.g., rainfall, infiltration and percolation), and  $d_t$  is the vector of water demands (e.g., off-takes by farmers) that act as system disturbances  $\epsilon_{t+1}$ . Note that (9) includes differential and algebraic equations: the former represent the system dynamics, and the latter account for the mass balances that must hold at the nodes.

### 2.2.3. Urban water networks

The integrated urban water cycle is composed of several infrastructural and operational components, including water sources management, water treatment, water transport and distribution, sewer/wastewater collection, and rainwater/stormwater drainage systems (Loucks & Van Beek, 2017), which have the main goal of providing water for human needs reliably, efficiently, and safely, and then returning it to the environment with the lowest possible impact (Walski et al., 2003). The problem of optimal operation of large-scale urban water networks has been extensively investigated in the literature in the last 50 years (Mala-Jetmarova, Sultanova, & Savic, 2017), with the main focus on water transport and distribution networks and optimal management of sewer and drainage infrastructure, beside smaller-scale applications that focus on solving local optimization problems of individual network components, such as individual pumps/pumping stations and water treatment processes in water/wastewater treatment plants.

Taking water transport and distribution networks for instance (see Fig. 3 for a schematic representation), an optimal control problem is typically formulated as an optimal pump operation and valve setting control problem targeting resources and economic savings in energy use and related cost, while ensuring that water is conveyed to final users

to satisfy their water demands. Modelling a water distribution network requires modelling its main components, which can be classified into *nodes* – which include demand junctions (where water leaves or enters the network), reservoirs (water sources), and tanks (where water is stored) – and *links* – which include pipes connecting different nodes and valves and pumps. Valves and pumps are the actuators in the system to be controlled. Accounting for all aforementioned system components, a control-oriented model of a water distribution network can be formulated as in Wang, Puig, and Cembrano (2017):

$$x_{t+1} = F(x_t, z_t, u_t, w_t, d_t), \tag{10a}$$

$$0 = G(x_t, z_t, u_t, w_t, d_t), \tag{10b}$$

where the dynamic states in vector  $x_t$  are the water storage levels (heads) of the network tanks at time step  $t$ , the algebraic states in vector  $z_t$  are the hydraulic heads in all other nodes of the network, resulting from flow balance,  $u_t$  is the vector of control inputs (pump operations and valve status), and  $w_t$  is the vector of non-controllable flows through pipes.  $d_t$  is the vector of water demand intended as system disturbances  $\epsilon_{t+1}$ . Pump and valves might vary in type and size. For instance, pumps might be with fixed-speed or variable-speed drives, valves might be pressure modulating or pressure reducing valves, non-return valves, head control, etc., which should be accounted for in modelling such components, as their characteristics also constrain the type and range of available controls.

The above discrete-time model includes difference and algebraic equations, based on mass and energy conservation. The mass balance should be guaranteed at the network nodes, implying that the flow rate of water  $q$  in node  $n$  from all its connected pipes  $p$  is balanced by the actual demand in that node  $d_t^{act,n}$  in each time step  $t$  (Rossman et al., 2000):

$$\sum_{p \in P_n} q_t^{p,n} - d_t^{act,n} = 0. \tag{11}$$

Energy conservation is formulated to satisfy the Bernoulli’s principle, while head losses in pipes are accounted for via the Hazen–Williams equation. Once the above model is formulated for a given water distribution network, the system can be simulated either in *demand-driven* mode, which, under normal conditions, assumes that the pressure in the system depends on node demands and, thus, the mass balance and head loss equations are solved assuming that node demands are known and satisfied, or in *pressure-driven* mode, which assumes that the delivered demand depends on the available pressure in the system and accounts for possible demand shortages. In emergency/anomaly situations (e.g., firefighting, power outages, pipe leaks), consumers do not always receive their requested demand in a pressure-driven scenario.



Several state-of-the-art software tools are available to model water distribution networks of various scales. Arguably, the most widely used among them is EPANET, developed as open-source software by the United States Environmental Protection Agency (Rossman et al., 2000). EPANET can perform also water quality simulation beside hydraulic simulations, thus allowing for coupled hydraulic and water quality simulation, which increases the size of the problem formulated in Eqs. (10) by adding states related to water quality parameters, along with the possibility of controlling their concentrations (e.g., via chlorine dosage). Yet, EPANET model implementations are not straightforward as control-oriented models, since they often include several switches and discrete operation conditions that make them not suitable for the direct application of gradient-based optimization approaches.

Alternative software tools exist to model other networks of the urban water cycle such as combined and sanitary sewers and other drainage systems, e.g., the US-EPA Storm Water Management Model (SWMM) (Rossman et al., 2010). A broad formulation of the system model as indicated in Eq. (10) and overall modelling strategy still stands, with water flows being ruled by mass and energy conservation laws. However, individual system components to be modelled change, with disturbances to be forecasted being most typically rainfall and inflow to the system, and controls being basin outflows, gate settings, and, more on an infrastructure planning perspective, Low-Impact Development (LID) controls. Complementary tools such as the one reported in Riaño-Briceño, Barreiro-Gomez, Ramirez-Jaime, Quijano, and Ocampo-Martinez (2016) allow the use of SWMM to design control strategies, in particular, applied to drainage systems, with some flexibility and considering dynamical models and a more realistic setup including disturbances and their forecast models.

In some cases, e.g., for large-scale urban water networks, it is useful to replace the full model of the system with a reduced model of the network that can offer higher computational efficiency (Shamir & Salomons, 2008). This is usually done via skeletonization by reducing the number of components of the system (e.g., by removing irrelevant pipes and nodes) while retaining a high level of similarity between the reduced and full model outputs and performance. Alternative approaches instead rely on the development of data-driven surrogate models.

### 2.3. Literature search and classification methods

This section describes the search methods, keywords and criteria followed for the bibliographic search highlighting common points and workflows across water systems, as well as differences (e.g., keywords, etc.). Real-time control techniques applied to water systems take sometimes different names but can be reduced to an MPC-like approach as long as they embed the three main blocks of MPC (see Introduction): (i) the internal model of the system, used to simulate the effects of the control actions on the system, (ii) the use of forecasts available in real-time, either real, synthetic or ‘perfect’ forecasts and (iii) an online optimization that is reiterated over a receding horizon. In the water systems’ literature, several studies have adopted an MPC-like technique either referring to it with different wordings, like ‘rolling horizon control’, ‘receding horizon control’, ‘real-time optimization’, or proposing some theoretical modifications to the MPC approach and providing an alternative name (e.g., Partial Open-loop Feedback Control). To account for such alternative wordings for “Model Predictive Control” and domain-specific differences, we formulated customized versions of the literature search string for each of the three water system types considered and used them to identify relevant papers in the Web of Science platform.<sup>3</sup> The resulting search strings are the following:

- For water reservoirs: (optimal AND water AND reservoir\* AND (operation OR control OR management) AND (predictive control OR forecast-based OR receding horizon OR rolling horizon OR receding-horizon OR rolling-horizon))
- For water channels: (Model predictive control OR MPC OR receding horizon OR rolling horizon) AND (water canal\* OR water channel\* OR irrigation OR inland OR inland waterway\*)
- For urban water networks: (optimal AND water AND (drinking OR distribution OR transport OR wastewater OR drainage OR grey water OR sewer OR sewage) AND (networks OR systems) AND (operation OR control OR management) AND (model predictive control OR predict\* control OR naive feedback control OR receding horizon OR rolling horizon OR receding-horizon OR rolling-horizon))

The search queries are not restricted to the word ‘Model Predictive Control’, so the records found include some irrelevant studies. Exclusion criteria only regarded (i) article language (only papers written in English were considered) and (ii) article type (only peer-reviewed publications in scientific journals were considered). Conference papers were excluded to avoid redundancies since some conference publications often present preliminary versions of studies subsequently published in full journal papers. We acknowledge that some of the most recent advanced developments, that might be present in a few recent peer-reviewed conference publications, may not have been covered in this review, but overall we do not expect that it would have a significant impact on the identified trends and challenges, given the large sample of journal articles included.

Manual filtering on the resulting records was performed based on paper title and abstract, to discard items that were out of scope for this review (i.e., not focusing on MPC or not applying it to the water systems of interest), before evaluating the eligibility of a restricted set of papers based on their full-text assessment. A smaller set of additional relevant papers not retrieved with the search query (7 items) was added to the final database from other sources, namely from references in previous review papers resulting from the search (see Fig. 4 for details on the sample selection).

## 3. Review results

### 3.1. MPC for water reservoirs

In the last 15 years, several studies analysed the potential of forecast-based real-time control techniques for water reservoir systems across different real-world problems by leveraging the increasing availability and improved quality of hydro-meteorological forecasts. The query formulated to retrieve peer-reviewed journal articles on MPC for water reservoir systems (see Section 2.3) returned an initial set of 105 papers. After screening these manuscripts, we retained 33 publications and added 7 more documents (from references in previous reviews on optimal control of reservoirs that were found by the query), yielding a total of 40 articles that have been analysed in detail (see PRISMA diagram in Fig. 4). As recently highlighted in Giuliani et al. (2021), our review confirms that MPC approaches (and analogous approaches that could be reduced to MPC) have been applied more commonly only in recent years, with the 40 studies reviewed here that have been published from 2008 to 2022 (see the temporal distribution in Fig. 5).

Almost all reviewed papers implement a centralized control architecture to determine the optimal releases from one or more reservoirs, with only a few applications also dealing with the control of pumps (e.g., Galelli, Goedbloed, Schwanenberg, & van Overloop, 2014; Javan Salehi & Shourian, 2021). Most studies implement a daily controller (e.g., Anghileri et al., 2016; Fan, Schwanenberg, Alvarado, dos Reis, Collischonn, & Naumman, 2016; Wan et al., 2016), but we found applications working at either sub-hourly (e.g., Breckpot, Agudelo, & De Moor, 2013; Lin et al., 2020) or hourly (e.g., Delgoda, Saleem, Halgamuge, & Malano, 2013; Karimanzira, Schwanenberg, Allen, & Barton,

<sup>3</sup> <https://www.webofscience.com/>

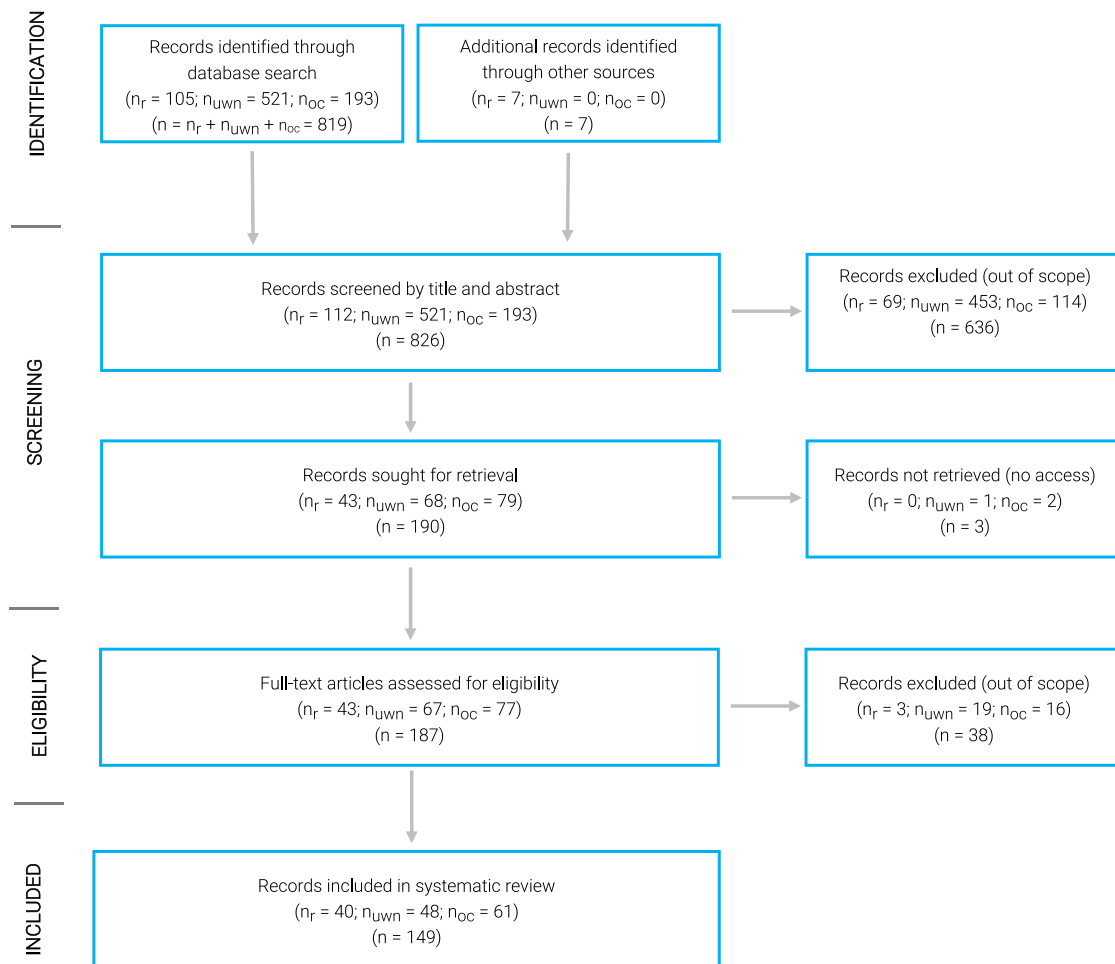

**Fig. 4.** Flow diagram with paper exclusion/inclusion criteria. The flow diagram reports the exclusion/inclusion criteria applied to the dataset of papers retrieved for review, represented according to the Preferred Reporting Items for Systematic Reviews and Meta-Analyses guidelines (PRISMA; Moher, Liberati, Tetzlaff, Altman, & PRISMA Group\*, 2009).  $n_r$  indicates the number of papers on MPC for water reservoirs (40),  $n_{UWN}$  those on MPC for urban water networks (48), and  $n_{OC}$  those on MPC for open channels (61, i.e. 58 research papers + 3 reviews).  $n$  is the number of total papers (equal to the sum of the above, i.e.,  $n = n_r + n_{UWN} + n_{OC}$ ). Detailed information about the reviewed papers and assigned tags are reported in Supplementary Tables 1-3.

2016; Lin, Rutten, & Tian, 2018; Romanowicz, Kiczko, & Napiorkowski, 2010; Xu et al., 2020; Zmijewski, Bottacin-Busolin, & Worman, 2016) or up to monthly (e.g., Cuvelier, Archambeau, Dewals, & Louveaux, 2018; Kistenmacher & Georgakakos, 2015; Zambelli, Soares Filho, Toscano, Santos, & Silva Filho, 2011) frequencies. Suppose the forecast frequency is not sufficient to timely inform the control action. In that case, the MPC results should be seen as a recommendation provided by a decision support system that the operator can adjust, potentially taking into account local expert knowledge and any operating factors that the MPC optimization could not cover (e.g., Roetz & Theobald, 2019).

In almost all the reviewed studies (see Table 1), the forecast represents the inflow to the reservoir, which is usually generated using a hydrological model fed by meteorological forecasts and any other significant information available at each control time step (e.g., snowpack and hydrological conditions, including the streamflow upstream, being routed using the model). Only two studies (Galelli, Castelletti, & Goedbloed, 2015; Galelli et al., 2014) complement the inflow with tide forecasts. Moreover, many studies (more than half) use a deterministic forecast and MPC formulation (e.g., Anand, Galelli, Samavedham, & Sundaramoorthy, 2013; Galelli et al., 2015; Giuliani & Castelletti, 2013), although the adoption of stochastic formulations is increasing in the last few years (e.g., Ahmad & Hussain, 2019; Sahu & McLaughlin, 2018; Uysal, Schwanenber, Alvarado-Montero & Sensoy, 2018b). These stochastic approaches (see Section 2.1.2 and Table 2) allow the explicit probabilistic characterization of the forecast uncertainty

by relying on ensemble forecasts and, therefore, better hedge against risk (Breckpot et al., 2013).

The reviewed papers used a wide range of control time steps (see Table 3) and of forecast horizons (also called *lead times* in the forecasting literature) ranging from a few hours for responding to rapid events such as floods (e.g., Blanco et al., 2010; Galelli et al., 2015, 2014; Xu et al., 2020) to seasonal or longer scales (e.g., Anghileri et al., 2016; Gavahi, Mousavi, & Ponnambalam, 2019; Raso & Malaterre, 2017; Xu, Zhao, Zhao, & Wang, 2015). However, multiple timescales have never been incorporated into a seamless multi-timescale system in any case study.

Despite changes in societal perceptions of water resources generally enlarge the number of objectives considered (e.g., Giuliani, Galelli & Soncini-Sessa, 2014; Giuliani, Herman, Castelletti & Reed, 2014; Wild, Reed, Loucks, Mallen-Cooper, & Jensen, 2019), a large majority of the studies we considered formulate a single-objective control problem (e.g., Arsenault & Cote, 2019; Breckpot et al., 2013; Sahu & McLaughlin, 2018; Wang, 2010; Xu et al., 2015) or an a-priori aggregation of multiple objectives (e.g., Castelletti et al., 2008a; Kistenmacher & Georgakakos, 2015; Uysal, Alvarado-Montero et al., 2018a), with very few exceptions that consider either 2 or 3 competing objectives (e.g., Giuliani & Castelletti, 2013; Lin et al., 2020; Mohanavelu, Soundharajan, & Kisi, 2022; Xu et al., 2020) (see Table 4). The scalability of MPC to multi- and many-objective control problems is indeed an important limitation for the application of this control strategy to

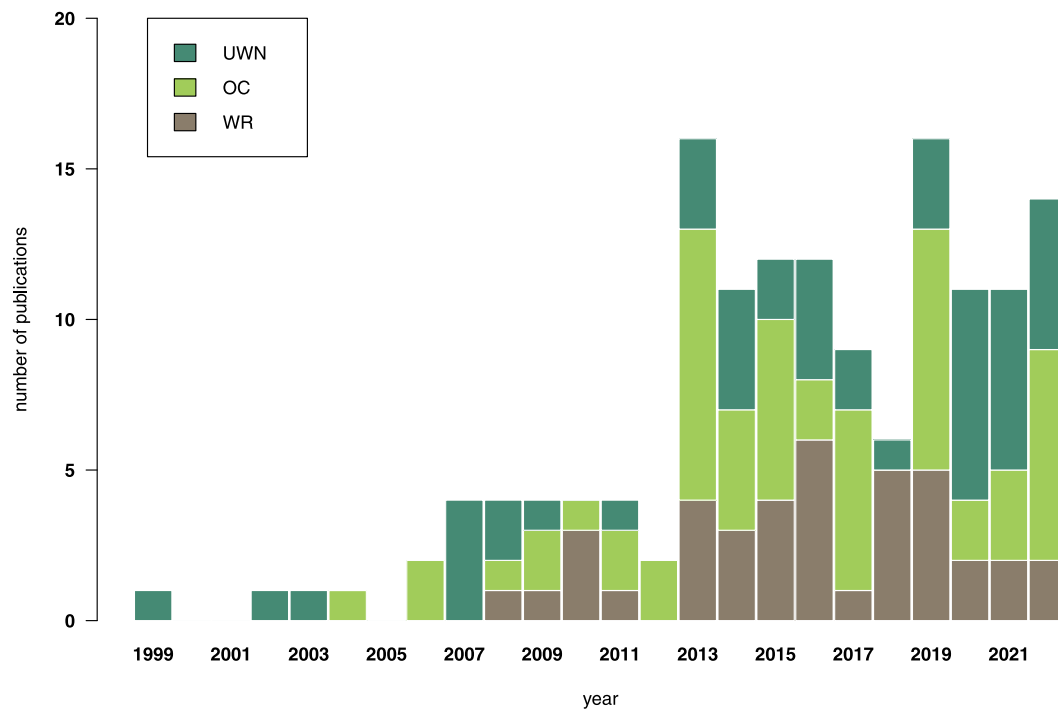

Fig. 5. Annual counts of the 149 publications reviewed in this study by type of water system (WR: Water Reservoirs; OC: Open Channels; UWN: Urban Water Networks).

Table 1

Summary of the disturbances and forecast features of the studies reviewed applying MPC to water systems, grouped by type of system (WR: Water Reservoirs; OC: Open Channels; UWN: Urban Water Networks). Numbers indicate the frequency for each class, with citations for rare features in the literature (up to 3 articles) to highlight the studies with peculiar or unique features (note that the sum of entries for each row can be larger than the total number of papers per type of system, as each paper can present more than one feature for each class).

Disturbance and forecast features									
Forecasted Variable	Rain-fall/inflow	Tide	Water demand	Electricity demand	Lock operations	Concentrations of chemical species	Wind	Head/water levels	Unclear
WR	40	2 (Galelli et al. (2014,2015))	0	0	0	0	0	0	0
OC	22	3 (van Ekeren et al. (2013), Tian et al. (2015), Pour et al. (2022))	33	1 (van der Heijden et al. (2022))	2 (Wagenpfeil et al. (2012), Segovia et al. (2019))	3 (Xu et al. (2013), Aydin et al. (2019), Aydin et al. (2022))	1 (Wagenpfeil et al. (2012))	0	0
UWN	9	0	31	0	0	1 (Dong and Yang (2019))	0	2 (Dong and Yang (2019), Kändler et al. (2022))	6
Forecast type (Perfect/Real)	Perfect		Statistical or ML-based (including synthetic)	Process-based	Hybrid (process-based + statistical/ML)		Complete lack of knowledge		Unclear
WR	15		21	16	2 (Ahmad and Hussain (2019), Wei and Xun (2019))		0		4
OC	35		6	5	1 (van Overloop et al. (2008))		13		9
UWN	7		22	1 (Shishegar et al. (2021))	0		0		22
Prediction Horizon	≤1hour	≤1day	≤1week	≤1month		≤1year	>1 year		Unclear
WR	0	5	12	9		7	4		3
OC	10	34	5	1 (Tian et al. (2015))		0	0		9
UWN	6	30	3 (Salomons and Housh (2020a), Salomons and Housh (2020b), Shishegar et al. (2021))		0		0		11

**Table 2**

Summary of the disturbances representation (deterministic and stochastic approaches, uncertainty model) of the studies reviewed applying MPC to water systems, grouped by type of system (WR: Water Reservoirs; OC: Open Channels; UWN: Urban Water Networks). Numbers indicate the frequency for each class, with citations for rare features in the literature (up to 3 articles) to highlight the studies with peculiar or unique features.

Disturbance and uncertainty representation					
		Deterministic	Stochastic	Both (Stochastic/Deterministic)	Unclear
Deterministic/ Stochastic	WR	23	13	4	0
	OC	52	4	2 (Maestre et al. (2013), Tian et al. (2017b))	0
	UWN	32	7	1 (Pedrosa et al. (2022))	8
Type of stochastic approach and ensemble size		Ensemble		PDF	
		≤10	≤30	>30	
WR		3 (Delgoda et al. (2013), Ficchi et al. (2016), Payet-Burin et al. (2021))	8	2 (Anghileri et al. (2016), Uysal et al. (2018b))	4
	OC	2 (van Overloop et al. (2008), Maestre et al. (2013))	3 (Tian et al. (2017b), Tian et al. (2019), Velarde et al. (2019))	1 (Nasir et al. (2019))	0
	UWN	0	0	1 (Grosso et al. (2017))	7
Operator over ensemble (implicit) or pdf (explicit)		Implicit		Explicit	
		Expected value	Tree	Min–max or quartiles	Expected value (PDF)
WR		8	4	3 (Cuvelier et al. (2018), Ahmad and Hussain (2019), Arsenault and Cote (2019))	4
	OC	3 (van Overloop et al. (2008), Tian et al. (2019), Nasir et al. (2021))	3 (Maestre et al. (2013), Tian et al. (2017b), Velarde et al. (2019))	0	0
	UWN	0	1 (Grosso et al. (2017))	0	7

Note: if the ensemble is reduced, the reduced ensemble size is reported, as the one used in the optimization problem.

water reservoir systems (Giuliani et al., 2021), which often has limited ability in exploring multi-dimensional trade-offs (e.g., Giuliani et al., 2016).

About half of the reviewed articles (see Table 4) provide a comparison between MPC against an alternative, off-line control strategy often designed via Stochastic Dynamic Programming (SDP) or against the current operational schemes of real-world reservoirs (e.g., Castelletti et al., 2008a; Sahu & McLaughlin, 2018; Xu et al., 2015). All these studies found that MPC outperforms other strategies. This is often attributed to the fact that MPC ensures that the control is adapting to extreme events that can be forecasted in the short- to long-term based on current observations and other forecast data (e.g., Ahmad & Hussain, 2019; Ficchi et al., 2016; Galelli et al., 2014). However, the choice of a reservoir control method is expected to depend upon multiple factors, including the system’s characteristics, the objectives of the control, the specified constraints, data and forecast availability (Macian-Sorribes & Pulido-Velazquez, 2020). So large comparison studies are needed to investigate MPC’s applicability, effectiveness, and value in different contexts.

Only a few studies benchmark MPC against multiple state-of-the-art control methods, such as different Approximate Dynamic Programming (ADP) methods (see Table 4). Notably, Mohanavelu et al. (2022) compare six state-of-the-art control methods for the operation of a real-world reservoir system in India (i.e., the Pong reservoir). They found that MPC outperforms all the other methods, yielding the closest solution to the ideal one designed via Deterministic Dynamic Programming (DDP). A limitation of their study is that MPC was driven by a single forecast close to perfect forecasts, so further studies are needed

to extend such comparisons for different case studies and use real forecasts with different levels of skill and timescales within the MPC. Similarly, Kergus, Formentin, Giuliani, and Castelletti (2022) benchmark an MPC-based approach against SDP and the ideal DDP solution with perfect foresight for the operation of a reservoir in Vietnam (Hoa Binh). Their MPC-like approach (combining hierarchically MPC with an inner parametric data-driven feedback controller) uses statistical forecasts with a random noise added on the disturbances. Despite the error in the disturbance predictions, the MPC-based approach outperforms SDP by obtaining better trade-offs between the two objectives (hydropower and flood control) and approaches the ideal solution by DDP. However, as pointed out by Kergus et al. (2022), while these results are encouraging for MPC, the robustness to prediction errors requires further investigation. Likewise, other six studies (Ahmad & Hussain, 2019; Castelletti et al., 2008a; Galelli et al., 2014; Payet-Burin, Kromman, Pereira-Cardenal, Strzepak, & Bauer-Gottwein, 2021; Sahu & McLaughlin, 2018; Wang, 2010) benchmark MPC with SDP reaching similar conclusions. MPC approaches outperform the offline benchmark by better anticipating the inflow events, especially those out of their typical season, even if a simple inflow forecasting model is used (e.g., Castelletti et al., 2008a; Wang, 2010). MPC generally leads to better trade-offs between objectives, with the performance increasing with increased prediction horizon (e.g., Castelletti et al., 2008a; Galelli et al., 2014). MPC can also deal with problems that are computationally intractable by SDP due to the number of reservoirs in the system (e.g., Wang, 2010), as it overcomes the curses of dimensionality and modelling of SDP.

A limitation of the current body of literature on MPC for reservoir operation is that most studies do not assess the impact of the MPC

**Table 3**

Summary of the control variable characteristics of the studies reviewed applying MPC to water systems, grouped by type of system (WR: Water Reservoirs; OC: Open Channels; UWN: Urban Water Networks). Numbers indicate the frequency for each class, with citations for rare features in the literature (up to 3 articles) to highlight the studies with peculiar or unique features.

Control-related information									
Frequency of control actions		≤1 hour	≤1 day	≤1 month	≤1 year	>1 year	Unclear		
		WR	11	18	9	1 (Xu et al. (2015))	0	1	
OC	51	3 (Foo et al. (2014), Tian et al. (2015,2017b))	0	0	0	4			
UWN	36	1 (Dong and Yang (2019))	0	0	0	11			
Number of control actions		1	≤5	≤10	≤50	>50	Unclear		
		WR	20	11	3 (Wang (2010), Kistenmacher and Georgakakos (2015), Karimanzira et al. (2016))	4	1 (Zmijewski et al. (2016))	1	
		OC	8	21	10	16	0	3	
		UWN	2 (Housh and Salomons (2019), Kändler et al. (2022))	14	10	7	11	4	
Type of control action		Reservoir release	Pump/valve operations	Gate operations	Chemical dosage	Other	Unclear		
		WR	39	4	4	0	3 (Galelli et al. (2014,2015), Gavahi et al. (2019))	0	
		OC	1 (Foo et al. (2014))	14	38	0	6	13	
		UWN	1 (Marinaki et al. (1999))	35	5	1 (Muslim et al. (2008))	5	2	
Control architecture (Centralized/Decentralized/Distributed, Single-level/Multi-level)		Centralized, single-level	Centralized, multi-level	Decentralized, single-level	Decentralized, multi-level	Distributed, single-level	Distributed, multi-level	Unclear	
		WR	40	0	2 (Giuliani and Castelletti (2013), Anand et al. (2013))	2 (Giuliani and Castelletti (2013), Anand et al. (2013))	0	0	0
		OC	46	1 (Pour et al. (2022))	0	3 (Sadowska et al. (2014,2015), Nasir et al. (2021))	4	4	0
		UWN	40	1 (Wang et al. (2017))	3 (Tedesco et al. (2016), Salomons and Housh (2020b), Martin et al. (2022))	0	0	0	5

internal model uncertainty, as usually the same models have been used for both the open-loop optimization and closed-loop simulation (with the associated update of model states) in almost all studies reviewed. A few exceptions exist (Lin et al., 2020; Munier, Polebistki, Brown, Belaud, & Lettenmaier, 2015). For example, Lin et al. (2020) used two different models: a simplified internal model was used in the open-loop optimization, as is usually done in MPC, and a more refined and computationally-intensive model was employed to represent the real water system in closed-loop, to update water levels and flows.

### 3.2. MPC for open channels

An initial set of 193 research journal papers was obtained using the query formulated in Section 2.3, of which only 58 were retained after the manual screening of titles and abstracts (see PRISMA diagram in

Fig. 4). Inspection of the time distribution of the final set of papers (depicted in Fig. 5) reveals that all papers were published less than twenty years ago (and twenty-six of them less than five years ago), which allows identifying a growing interest in the topic (see Fig. 5). It is also worth noting that three other review papers were returned by the query: although not strictly research papers, they are surveyed for completeness. An exhaustive review of modelling and control of open-channel irrigation systems is carried out in Conde et al. (2021), and an entire section (Section 4.5.3) is devoted to MPC. Different applications of smart agriculture are presented in Ding et al. (2018), including the use of MPC for irrigation systems (Section 3.1). The developments of an industrial-scale project that culminated in the complete automation of a large irrigation system in Australia are discussed in Mareels et al. (2005). Although MPC approaches are not explicitly developed therein, the same research group has recently employed MPC to control a



**Table 4**

Summary of the problem size (state variables), objectives (number and type), and benchmarking of the studies reviewed applying MPC to water systems, grouped by type of system (WR: Water Reservoirs; OC: Open Channels; UWN: Urban Water Networks). Numbers indicate the frequency for each class, with citations for rare features in the literature (up to 3 articles) to highlight the studies with peculiar or unique features.

System size, objectives and benchmarking								
Number of state variables		≤5	≤10	≤50	>50	Unclear		
	WR		30	3 (Wang (2010), Kistenmacher and Georgakakos (2015), Karimanzira et al. (2016))	3 (Lin et al. (2018,2020), Salehi and Shourian (2021))	1 (Blanco et al. (2010))	3	
OC		18	9	18	9	4		
UWN		11	7	8	6	16		
Number of objectives		1 (including weighted/aggregated)	≤4	>4	Unclear			
	WR		35	5	0	0		
OC		57	1 (Tian et al. (2019))	0	0			
UWN		42	3 (Housh and Salomons (2019), Liu et al. (2020), Trapiello et al. (2021))	0	3 (Muslim et al. (2008), Bakker et al. (2013), Kändler et al. (2022))			
Objective type		Economic (cost minimization)	Flood/overflow minimization/water level control	Water supply/demand satisfaction	Active actuator minimization/smooth operations	Contaminant/salinity concentration minimization	Environmental protection (environmental flow)	Hydropower
	WR	8	25	18	2 (Karimanzira et al. (2016), Uysal et al. (2018a))	1 (Galelli et al. (2015))	4	17
OC	8	55	2 (Foo et al. (2014), Horvath et al. (2022))	47	2 (Aydin et al. (2019,2022))	2 (Foo et al. (2014), Horvath et al. (2022))	1 (Doan et al. (2013))	
UWN	29	14	13	24	4	0	0	
Benchmark		DDP (Deterministic Dynamic Programming)	SDP (Stochastic Dynamic Programming)	Historical operation or current curves	PI control	LQR	No benchmark/unclear	
	WR	4	8	11	0	0	19	
OC	0	0	2 (Foo et al. (2014), Askari Fard et al. (2022))	6	5	46		
UWN	0	0	14	2 (Muslim et al. (2008), Fiorelli et al. (2013))	1 (Marinaki et al. (1999))	25		

river (Foo, Ooi, & Weyer, 2014) and an irrigation canal (Nasir, Cantoni, Li, & Weyer, 2021).

Control of water canals and rivers aims to satisfy human needs, which are expressed in the form of a cost function. Most of the reviewed papers are characterized by cost functions built as the weighted sum of individual terms (i.e., the relative importance of each term is adjusted using weights), with the minimization of water level setpoint tracking errors and operational costs being the most common objectives (see Table 4). Additional goals, e.g., simultaneous control of water quantity and quality (Aydin, Essink, Delsman, van de Giesen, & Abraham, 2022; Aydin et al., 2019; Xu, van Overloop, & van de Giesen, 2013), preservation of water levels within safe navigation bounds (Horvath et al., 2022; Pour, Segovia, Duviella, & Puig, 2022; Segovia, Rajaoarisoa, Nejari, Duviella, & Puig, 2019; Tian et al., 2019; Wagenpfeil, Arnold, Linke, & Sawodny, 2012) and pressure reduction for the pressurized part of the network (Zhu et al., 2020), are also considered in the literature. Moreover, Foo et al. (2014) tailor a cost function to the needs of their case study, e.g., maintain off-stream storage volume above a threshold, release as little water from a lake as possible and keep flows for early spring to mid-summer under a threshold to create slack-water pockets. On a wider note, joint water and energy management in water canals

appears to be a topic of increasing interest in the water-energy nexus context (Doan, Giselsson, Keviczky, De Schutter, & Rantzer, 2013; Horvath et al., 2022; Pour et al., 2022; van der Heijden, Lugt, van Nooijen, Palensky, & Abraham, 2022).

Operational management of water canals is carried out by manipulating the available actuators. Inspection of the surveyed papers reveals the use of a wide variety of actuators, i.e., gates, weirs, sluices, pumping stations, dams, turbines and electro-valves (see Table 3). Control decisions are either actuator flow or position setpoints; an assessment of the optimal choice of the input variable is carried out in Horvath, Galvis, Gomez Valentin, and Rodellar Benede (2015b). These decisions are computed over prediction horizons (the reviewed papers report values ranging from one minute to ten days), and are applied with fixed frequencies (ranging from once every five seconds to once every six hours) for the whole duration of the experiment (ranging from thirty minutes to one year). The effect of these decisions on the system is measured using available sensors that capture relevant information, e.g., water levels, salinity and concentration of chemical species. This information, together with estimates of unmeasurable states (obtained using observers), allows adjusting the decisions at the next time step. It is interesting to highlight the large variability in terms of time scales

across reviewed papers (see Tables 1 and 3). These differences can be explained by the different nature of the experiments: real case studies, either on a real system (Foo et al., 2014; Nasir et al., 2021) or in silico (Kong, Quan, Yang, Song & Zhu, 2019; Romera, Ocampo-Martinez, Puig, & Quevedo, 2013; Tian, Aydin, Negenborn, van de Giesen & Maestre, 2017a), laboratory canals (Aydin, van Overloop, Rutten, & Tian, 2017; Figueiredo, Botto, & Rijo, 2013; Horvath, Galvis, Gomez Valentin, & Rodellar, 2015a; Horvath et al., 2015b; Lemos et al., 2009; van Overloop, Horvath, & Aydin, 2014), canal benchmarks (Rodriguez, Maestre, Camacho, & Sanchez, 2020; Wahlin, 2004; Wahlin & Clemmens, 2006b) and academic examples (Breckpot et al., 2013; Xu, Negenborn, van Overloop, & van de Giesen, 2012; Xu, van Overloop, & van de Giesen, 2011; Xu et al., 2013; Xu & Schwanenberg, 2017) are reported. In particular, laboratory canals are characterized by reduced dimensions in comparison to the rest of the case studies, which explains the use of smaller time scales.

It was discussed in Section 2.1 that MPC is a model-based approach and that, as such, an internal model is required to predict the effect of control actions on the system. Existing open-channel internal models have been presented in Section 2.2.2. On the one hand, some of the employed models are directly derived from the Saint-Venant equations, e.g., discretizing the system in space and linearizing (Aydin et al., 2022, 2019; Tian, van Overloop, Negenborn, & van de Giesen, 2015; Wagenpfeil et al., 2012; Xu et al., 2012). On the other hand, other papers resort to the integrator delay (Askari Fard, Hashemy Shahdany, Javadi, & Maestre, 2022; Avargani et al., 2022; Hashemy Shahdany, Hasani, Majidi, & Maestre, 2017; Kong, Quan et al., 2019; Liu, Wang, Yang, & Zhang, 2023; Rodriguez et al., 2020; Zheng, Wang, Zhao, & Zheng, 2019), the integrator delay zero (Pour et al., 2022; Romera et al., 2013; Segovia et al., 2019) and the integrator resonance (Horvath et al., 2015a, 2015b; van Overloop et al., 2014) models. While a large variety of models is employed in the reviewed papers, it can be concluded that the use of the ID model is prevalent (in its equivalent state–space form). Finally, a model-free strategy is proposed by Ren et al. (2021), whereby control policies are obtained via deep reinforcement learning.

The performance of MPC is also affected by disturbances. Water canals are operated under time-varying environmental conditions, which are exogenous inputs that attenuate the effect of control actions and thus complicate the attainment of the operational objectives. Therefore, the occurrence of these events may have a severe effect on water levels unless properly accounted for in the MPC design. Although the type of disturbance considered depends on the case study, uncontrolled in- and/or outflow forecasts, e.g., rainfall (Maestre et al., 2013; Negenborn, van Overloop, Keviczky, & De Schutter, 2009; van Overloop et al., 2008; Velarde et al., 2019; Xu et al., 2011), surface-groundwater interaction (Aydin et al., 2019; Foo et al., 2014) and sea discharges (Tian et al., 2015; van der Heijden et al., 2022; van Ekeren, Negenborn, van Overloop, & De Schutter, 2013), are typically used (see Table 1). In addition to these, operational disturbances, e.g., off-take flows for irrigation purposes (Breckpot et al., 2013; Hashemy, Monem, Maestre, & Van Overloop, 2013; Kong, Lei et al., 2019; Kong, Song, Ji, Zhu, & Li, 2021; Shahdany, Maestre, & van Overloop, 2015; Shahdany, Majd, Firoozfar, & Maestre, 2016; Shahdany, Taghvaeian, Maestre, & Firoozfar, 2019; van Overloop, Clemmens, Strand, Wage-maker & Bautista, 2010; van Overloop, Maestre, Sadowska, Camacho, & De Schutter, 2015; Wahlin, 2004; Wahlin & Clemmens, 2006a, 2006b; Xu, 2017; Zheng et al., 2019), wind effect (Wagenpfeil et al., 2012) and lock operations for navigation purposes (Pour et al., 2022; Segovia et al., 2019), are also considered. While either perfect or no knowledge about operational demands is usually considered (scheduled and unscheduled operations, respectively), uncertain meteorological conditions have motivated the development of stochastic MPC approaches for water canals (Maestre et al., 2013; Nasir et al., 2021; Tian et al., 2019; Tian, Negenborn et al., 2017b; van Overloop et al., 2008; Velarde et al., 2019), whereby different disturbance realizations with individual occurrence probabilities are considered (see Table 2).

In terms of the architecture of controllers for water canals, given the characteristics of centralized/distributed controllers (as introduced in Section 2.1), distributed control architectures appear to be preferable to overcome the computational and scalability drawbacks arising from centralized implementations. However, only eight papers consider distributed architectures (see Table 3), of which four are characterized by a two-layer structure in which the top layer takes care of the high-level problem setup: uncertainty realization (Velarde et al., 2019), reduction of communication overhead among local controllers (Farhadi & Khodabandehlou, 2016), selection of optimal network topology (Fele, Maestre, Hashemy, Munoz de la Pena, & Camacho, 2014) and execution of risk mitigation actions (Zafra-Cabeza, Maestre, Ridao, Camacho, & Sanchez, 2011). The remaining four papers consider distributed single-level architectures (Alvarez, Ridao, Ramirez, & Sanchez, 2013; Doan et al., 2013; Maestre et al., 2013; Negenborn et al., 2009). The reduced number of papers that employ distributed multi-level architectures may be explained by the fact that the choice of control architecture depends mostly on the extent to which systems are coupled, communication reliability and computational resource availability. Canals have been traditionally regulated either manually or using decentralized proportional–integral (PI) controllers that adjust the setpoints dictated by a centralized coordinator (Nasir et al., 2021; Sadowska, De Schutter, & van Overloop, 2015; Sadowska, van Overloop, Burt, & De Schutter, 2014), which means that coupling effects might not be too relevant for their usual operation.

The benchmarking of MPC performance against other approaches is rarely included in the literature on open-channel control, as shown in Table 4. MPC is only compared to other two control approaches, namely LQR (Kong, Lei et al., 2019; Liu et al., 2023; van Overloop, Clemmens et al., 2010; Wahlin & Clemmens, 2006a; Zheng et al., 2019) and PI(D) (Figueiredo et al., 2013; Foo et al., 2014; Kong, Lei et al., 2019; Lemos et al., 2009; Liu et al., 2023; van Overloop et al., 2015, 2008; Wahlin, 2004; Wahlin & Clemmens, 2006b), whereby the superior performance of MPC is demonstrated. Furthermore, although not explicitly reported in Table 4, benchmarking MPC against manual control demonstrates that MPC leads to better performance and thus improved system operation (Askari Fard et al., 2022; Foo et al., 2014).

As a final remark, not all papers report information regarding, e.g., nature of the forecast, system size (number of states), prediction horizon, frequency of decisions and optimization method, in an explicit manner. This fact complicates the analysis of the reviewed references.

### 3.3. MPC for urban water networks

The query to retrieve peer-reviewed journal articles on MPC developments and applications to control urban water networks (see Section 2.3) returned an initial set of 521 papers. From this set of papers, 453 were excluded from further analysis after manually screening each paper's title and abstract, 1 was not accessible to the authors, and 19 more were excluded based on relevance and fit within the scope of this review (see PRISMA diagram in Fig. 4). As a result, a subset of 48 articles was retained for detailed tagging and classification. This group of 48 papers corresponds to 9.2% of the initial dataset of papers retrieved with the formulated query. Many of the excluded papers were initially obtained as a result of the search query because they include the keywords listed in the search query in their main text or other parts. However, they were then deemed not relevant in relation to the scope of this review primarily either because of their actual MPC implementation (they only mentioned MPC or other control schemes but eventually only focused on model development), or because of their spatial scale of interest. Many studies indeed mentioned urban water systems and networks but eventually focused only on optimal control of processes occurring in individual network components (e.g., water treatment plants). For the above reasons, many papers initially identified in the search were assessed as not eligible for consideration in this review. The time distribution of these 48 articles shows that

the last 25 years have witnessed an increasing interest towards the implementation of MPC schemes to control urban water networks. Likely motivated by the increasing amount of (quasi) real-time sensor data from distributed infrastructure networks, which act as enablers of real-time control schemes (Creaco et al., 2019), more than 45% of the reviewed studies ( $n = 22$ ) were published in the last 5 years only (see Fig. 5).

Integrated urban water management requires optimal planning and operations of different network systems which make up the urban water cycle, including drinking water networks, stormwater, greywater, and wastewater networks. Accordingly, examples of MPC developments and applications emerge from the literature on supply-side management of drinking water networks and stormwater and wastewater management. In addition, other recent publications reviewed the existing literature on control schemes for urban water networks. Yet, their scope is rather constrained to only one type of network infrastructure, i.e., sewer and drainage systems (Lund, Falk, Borup, Madsen, & Steen Mikkelsen, 2018; Van Der Werf et al., 2022) or water supply and distribution networks (Coelho & Andrade-Campos, 2014), and various control schemes are considered. Conversely, the scope of this review is only spatially constrained by the boundaries of the integrated urban water system and thematically by the focus on MPC-like control. Still, it is inclusive of all its sub-components. This review thus compares MPC studies focused on drinking water networks, as well as wastewater and sewage networks, to identify the type of disturbances, objectives, actuators, and type of MPC in each case, ultimately evaluating the benefits brought by MPC and its related challenges.

Most of the reviewed papers address the problem of optimal control of water distribution and transport networks ( $n = 34$ ). The typical research goal in these works is to identify optimal operations of pumps and valves, i.e., the actuators distributed in a water distribution/transport network. The number of actuators in network infrastructure systems depends on the considered network's topological and structural characteristics and size. Their number affects the number of control variables in the optimal control problem. In our compilation of reviewed papers (see Table 3), control variables vary from less than 10 in simplified or small systems (e.g., Housh & Salomons, 2019; Rao & Salomons, 2007; Salomons & Housh, 2020a, 2020b; Sankar, Kumar, Narasimhan, Narasimhan, & Bhallamudi, 2015) to more than 120 in larger, real-world systems (Cembrano, Quevedo, Puig, Pérez, Figueras, Verdejo, Escaler, Ramón, Barnet, Rodríguez, et al., 2011; Ocampo-Martinez, Bovo, & Puig, 2011). Water distribution systems are operated under varying water demand conditions. Forecasts of water demand are thus needed as input to the underlying hydraulic or data-driven models used in MPC. Water demand forecasts usually span over a period of 24 h, relying on the day/night periodicity of water demand patterns, whereas the frequency of decisions is in the range of a few minutes (e.g., 5 min as in Liu, Zheng, Wu, and Li (2020)) and 1 h (Limon, Pereira, De La Peña, Alamo, & Grosso, 2014; Pascual, Romera, Puig, Cembrano, Creus, & Minoves, 2013; Pereira, de la Peña, Limon, Alvarado, & Alamo, 2016; Wang, Ocampo-Martinez, & Puig, 2016; Wang, Taha, Gatsis, & Giacomoni, 2020). Controls in water transport and distribution networks are computed in such a way that an economic objective accounting for the cost of running the system (mainly due to electricity consumption for water pumping and pump start-up costs) is minimized, while water demands in the system are satisfied (e.g., Shamir & Salomons, 2008). Additional objectives such as guaranteeing safety storage in water tanks, pressure control, or smoothness of the controls are also often weighted in the complete objective function (e.g., Grosso, Ocampo-Martinez, Puig, & Joseph, 2014; Grosso, Ocampo-Martinez, & Puig Cayuela, 2016; Martin, Delgado-Aguinaga, & Puig, 2022; Ocampo-Martinez, Barcelli, Puig, & Bemporad, 2012; Pour, Puig, & Cembrano, 2019, 2020; Wang et al., 2017; Wang, Salvador, de la Pena, Puig, & Cembrano, 2018). Only three recent papers explicitly consider multiple objectives, including one on optimal reconfigurations of large-scale systems via backup

actuator activation formulated as a multi-objective mixed-integer programming (MIP) problem with two separate objectives (see Table 3), which was then solved with a lexicographic approach (Trapiello, Puig, & Cembrano, 2021). A minority of works also considers water quality objectives, typically quantified via chlorine concentration in the supplied water (Biscos, Mulholland, Le Lann, Brouckaert, Bailey, & Roustan, 2002; Biscos, Mulholland, Le Lann, Buckley, & Brouckaert, 2003; Muslim, Li, & Tade, 2008).

The remaining 14 papers deal with optimal management of sewer and drainage infrastructure, where pumps and gates should be controlled to guarantee cost-effective and smooth operations, reduced peak flow to wastewater treatment plants, flood control, and avoid overflow in combined systems (CSOs; Darsono & Labadie, 2007; Dong & Yang, 2019; El Ghazouli, El Khatabi, Soulhi, & Shahrour, 2022; Joseph-Duran, Jung, Ocampo-Martinez, Sager, & Cembrano, 2014a; Joseph-Duran, Ocampo-Martinez, & Cembrano, 2014b, 2015; Kändler, Annus, & Vassiljev, 2022; Marinaki, Papageorgiou, & Messmer, 1999; Puig et al., 2009; Shishegar, Duchesne, Pelletier, & Ghorbani, 2021; Sun et al., 2020; Svensen, Sun, Cembrano, & Puig, 2021; Wang, Tian, & Liao, 2021a; van der Werf, Kapelan, & Langeveld, 2021). Rainfall is usually the uncertain variable to be forecasted (see Table 1), typically with a sub-hourly prediction horizon (e.g., 30 mins in Joseph-Duran et al., 2014b; Sun et al., 2020), which provides information on the expected inflow to the system to design optimal decisions of gates to be applied with an operational frequency of 1–5 min (Joseph-Duran et al., 2014b, 2015; Marinaki et al., 1999; Sun et al., 2020) to a few hours or a day (Dong & Yang, 2019).

Further, a limited yet recently growing number of articles (not included in this review) develops control schemes based on MPC to operate pumps as turbines and harness the excess energy that would be otherwise dissipated for electricity production (Levieux, Ocampo-Martinez, Inthamoussou, & De Battista, 2021; Pirard et al., 2022; Stefanizzi et al., 2020; Venturini, Alvisi, Simani, & Manservigi, 2017). While they are not included in this review because they are not directly concerned with the optimal management of water resources, it is worth mentioning them as recent literature is shaping around joint opportunities for water and energy management within the broader context of the water-energy nexus.

The reviewed papers present a variety of applications and case studies, with different formulations of the objective function, controls, disturbances and forecasting horizon, system characteristics, and overall goals. Hence, results are also often case-specific and hard to generalize. However, in most reviewed works, MPC schemes – primarily implemented with a centralized architecture – are benchmarked against other control strategies and comparatively attain a better performance (i.e., reduced operational costs and violation of physical and operational constraints). Historical/current rule-based controls are usually taken as baseline reference (e.g., in Bakker, Vreeburg, Palmen, Sperber, Bakker, & Rietveld, 2013; Balla, Bendtsen, Kallesøe, & Ocampo-Martinez, 2022; Guo, Wang, Taha, & Summers, 2022; Salomons, Goryashko, Shamir, Rao, & Alvisi, 2007; Wang et al., 2020), along with local controllers (Puig et al., 2009) and PI controllers (Fiorelli, Schutz, Metla, & Meyers, 2013; Muslim et al., 2008) in a limited number of cases. A solid alternative for either implementing non-centralized control approaches or complementing control strategies for the management of UWNs is based on evolutionary game theory (Quijano et al., 2017). For the former case, several proposals have been reported towards not only designing predictive controllers accounting for the suitable partitioning of a large-scale drinking water network (Barreiro-Gomez, Ocampo-Martinez, & Quijano, 2019; Muros, Maestre, Ocampo-Martinez, Algaba, & Camacho, 2018) but also the synthesis of control strategies entirely based on such game theory (Barreiro-Gomez, Ocampo-Martinez, Quijano, & Maestre, 2017; Barreiro-Gomez, Quijano, & Ocampo-Martinez, 2016; Obando, Quijano, & Ocampo-Martinez, 2022). Regarding game-theory-based approaches



that assist a predictive controller, tuning methodologies for multi-objective predictive controllers are also reported (Barreiro-Gomez, Ocampo-Martinez & Quijano, 2017).

Overall, MPC has proven to be effective in attaining substantial cost savings in comparison to existing rule-based or set-point controllers in water distribution networks, which usually operate based on storage level thresholds. For instance, energy cost savings between 8% and 10% were calculated with simulations for a summer and winter month in Shamir and Salomons (2008). Other studies considering MPC controllers in urban drainage networks found that MPC can reduce the number of flooded nodes during an extreme weather event and lower peak flow by more than 50% in drainage systems subject to heavy rainfall events (Kändler et al., 2022; Shishegar et al., 2021). Case-specific results and cost/energy savings referred to different baseline values, implementations of the objective functions, and MPC parameters, though, do not allow for a direct quantitative comparison of MPC performance across studies. Further, several limitations and existing research gaps emerge from the analysis of the 48 reviewed papers. Most of the considered studies adopt, at least to some extent, a series of simplifications to address the challenges related to (i) accounting for uncertainties in disturbance prediction and (ii) dealing with the computational burden of simulating potentially large real-world networks in model-based approaches.

Concerning the first group of challenges, only eight studies out of 48 consider the uncertainty in disturbance forecasts by implementing a stochastic or combined deterministic and stochastic MPC approach (e.g., Grosso, Velarde, Ocampo-Martinez, Maestre, & Puig, 2017; Pedrosa, Puig, & Nejjari, 2022). The majority instead focuses on demonstrating the superiority of MPC in comparison to other control strategies under a deterministic scenario. This scenario is sometimes built assuming perfect disturbance prediction (Marinaki et al., 1999; Tedesco, Ocampo-Martinez, Casavola, & Puig, 2016) or simple statistics on water demands from past data, while the type of forecast remains unclear in many other cases.

Concerning the second group of challenges, reducing the computational effort required to simulate large real-world networks is addressed in the literature with three different types of simplification approaches. First, some studies only consider very small networks, usually built ad hoc as artificial systems for research purposes, composed of a handful of nodes and just a few actuators (e.g., Sankar et al., 2015; Sun, Puig, & Cembrano, 2016). This approach also makes up for the lack of data that often limits the possibility of developing studies based on real-world urban water networks. Other studies instead simplify the size of existing real-world systems by removing irrelevant nodes and links and obtaining a *skeletonized* system (as, for instance, in Shamir & Salomons, 2008). Beside the physical properties of the considered system, its operational properties and the physical characteristics of its actuators are often simplified, too. For example, some work only consider fixed-speed pumps, simple valve models characterized only by upper and lower bounds on the flow, and none consider dynamic/time-varying energy prices, but a few exceptions. Our review found that approximately 32 studies are based on simplified or synthetic case studies, while only 16 rely on full-scale real-world systems or systems not explicitly simplified. A third strategy to deal with the computational effort required by the simulation of large-scale hydraulic networks is the implementation of data-driven surrogate (or meta-) models that substitute the high-fidelity hydraulic model with more computationally efficient yet still accurate models that can be coupled with optimization. Dong and Yang (2019), for instance, implement a long-short-term memory (LSTM) neural network for operation scheduling of water diversion and drainage pumping stations in the presence of complex hydrometeorological constraints. Many research efforts have been recently developed revolving around surrogate models, also pushed by recent development in artificial neural networks and deep learning (e.g., Fiedler, Cominola, & Lucia, 2020). As many are pretty recent and only appear so far in

conference proceedings, they might not have been captured by our review.

Finally, it must be noted that, while it was possible to identify the above trends and challenges, one non-negligible finding is that many works do not report sufficient details on the type of forecasts, system size (state variables), implemented optimization method, benchmark, and in some cases even the actual formulation of the objective function. This limits our capabilities to carry out a complete analysis of the attributes of such studies and, in general, hampers their full reproducibility.

#### 4. Discussion

While the three types of water systems considered (water reservoirs, open channels and urban water networks) feature domain-specific physical characteristics and different types of actuators, objectives, and disturbances that should be accounted for in a control problem, common advantages/drawbacks of MPC, trends and challenges emerge from this review.

MPC offers three primary advantages over more conventional SDP and ADP methods: (A1) MPC overcomes the so-called ‘curse of dimensionality’ of Dynamic Programming, as it avoids the computation of the value function, by iterating the optimal control problem over a finite receding horizon; as a result, the computation costs of MPC do not increase exponentially with problem size (i.e., state and control dimension), which makes MPC a more viable approach for large-scale multi-reservoir systems with more than three reservoirs (e.g., Ficchi et al., 2016; Kistenmacher & Georgakakos, 2015; Wang, 2010), as well as for large OC (e.g., Kong et al., 2021; Rodriguez et al., 2020; Shahdany et al., 2019) and UWN (e.g., Martínez, Hernández, Alonso, Rao, & Alvisi, 2007; Tedesco et al., 2016; Wang et al., 2021b). (A2) MPC overcomes the ‘curse of modeling’ of DP by allowing the optimization model to take updated decisions at each time step with a real-time receding horizon strategy, making use of existing models and optimization frameworks (e.g., Mohanavelu et al., 2022; Nasir et al., 2021; Segovia et al., 2019). (A3) MPC can deal with hydro-climatic variability, nonstationarities and uncertainty (e.g., Castelletti et al., 2008a; Maestre et al., 2013; Payet-Burin et al., 2021; Velarde et al., 2019). By using real-time information and probabilistic forecasts in the optimization process, MPC allows water systems operation to adapt to changes in the climate or catchment and to mitigate the impacts of extreme hydrological events anticipating them, particularly those occurring in unusual periods of the year (e.g., Castelletti et al., 2008a). These advantages make MPC a more effective control technique and more feasible than DP for large water systems (especially large channel and urban water networks), as shown in a few studies benchmarking MPC against DP/ADP methods.

Although MPC has these advantages over more conventional DP and off-line methods, it also has a few drawbacks: (D1) The iterative optimization involved in MPC can also lead to intensive computations, especially for large-scale water systems with many actuators and a centralized controller. For example, for open channels, Ren et al. (2021) discuss how the computation burden associated with MPC can be a significant obstacle in large-scale systems with high-dimensional state and control spaces, making it impractical to perform online calculations at each time step; they call this a ‘curse of dimensionality’ for MPC too, though this is less prohibitive than for DP. Other authors have also paid attention to the trade-off between solution optimality and computation time, and have tested different MPC formulations to verify conditions under which optimal control actions may be determined within a prescribed real-time control period. For instance, Xu et al. (2012) test quadratic-programming-based (QP) and sequential-quadratic-programming-based (SQP) MPC, and find out that SQP-MPC achieves better control performance than QP-MPC at the expense of highly increased computation times (execution is 30 times slower). Alternative approaches to overcome the costs related to centralized

MPC controllers applied to large-scale systems and to foster scalability have been explored also in urban water networks. Tedesco et al. (2016), for instance, test the use of distributed approaches (command governor strategies), in which the global control system is decomposed and local controllers are used, each responsible for the supervision of each subsystem. (D2) The performance of MPC is highly dependent on reliable prediction models, which may not be available for large-scale systems over long prediction horizons, making MPC-based control approaches ineffective in some cases (e.g., Ren et al., 2021).

Two main common trends can be identified: (T1) an increasing number of studies adopting ML-based models to predict the disturbances (e.g., inflows, tides); (T2) an expanding proportion of stochastic MPC applications over the last decade (since 2013), though still a minority to deterministic MPC.

The main challenges currently limiting the scope of MPC studies can be grouped into the following four categories, which should serve as main goals to formulate a research agenda for the next few years: (C1) lack of benchmarking studies that comprehensively compare MPC against other control schemes and assess its performance in relation to the characteristics of the physical system; (C2) lack of assessment of the uncertainty embedded in the model-based control and simplifications adopted in the model structure; (C3) incomplete analysis on the impact of the type of forecast, forecast resolution, and length of the prediction horizon; and (C4) limited exploration of tradeoffs and truly multi-objective MPC problems, to go beyond the single-objective nature of the problem formulation (that is often achieved via aggregation of multiple objectives functions appearing in multi-objective problems).

Related to the first challenge (C1) of evaluating the performance of MPC comprehensively and objectively, in most of the reviewed studies, there is a lack of consistent benchmarking of MPC with respect to other control methods and across systems with different characteristics. Only a few studies compare MPC against multiple alternative techniques, and none compare MPC with off-line alternatives using available forecasts in real-world settings. Most past studies across all types of considered water systems either used only perfect forecasts to set the upper-bound performance used as “ideal” Ref. (e.g., Marinaki et al., 1999; Uysal, Alvarado-Montero et al., 2018a), or focused on an off-line benchmark control scheme without actual forecasts, but rather with historical operations, typically based on rule curves or other set-point approaches (e.g., Delgoda et al., 2013; Wang et al., 2020; Xu et al., 2015) and Stochastic Dynamic Programming (e.g., Galelli et al., 2014; Kergus et al., 2022; Wang, 2010). A comparative analysis of the MPC performance in different contexts and in relation to case-specific characteristics (e.g., physical features of the system, constraints, objectives, etc.) would be important to assess the dependence between such characteristics and expected MPC results. However, many different factors are varying across the reviewed studies and for different types of systems, both in terms of system characteristics and optimization problem parameters. Thus, a direct comparison of existing quantitative results would not be meaningful. A fair comparative analysis would instead require consistent benchmarking studies comparing the relative performance of MPC with respect to the same benchmark control method across studies. We acknowledge that the performance of MPC can be affected by the characteristics of the basin, hydrology of the open channels, and other factors, which can vary significantly between different geographic regions. Therefore, further studies carrying out comparative analyses of MPC with consistent settings and with real-world data (beside synthetic cases, which are frequent in the reviewed papers) should be considered for water reservoirs, urban water networks, and open channels.

As for C2, the key element of MPC is the use of a model of the system to be controlled, yet models are always subject to errors, inaccuracies, and uncertainties. MPC leverages the accuracy of the models of the systems to ensure the robustness of the controller with respect to uncertainties (e.g., Schwenzler et al., 2021). Many studies reviewed recognize this aspect and provide at least some insights into

the accuracy of the chosen internal models, supporting their choice (e.g., Ficchi et al., 2016; Galelli et al., 2014; Giuliani & Castelletti, 2013; Munier et al., 2015). However, some studies do not analyse the model’s accuracy in sufficient detail, and few do not provide any information on this. Moreover, most of the studies reviewed (more than 100 out of 149) do not assess the impact of the MPC internal model uncertainty as usually the same models for both the open-loop optimization and closed-loop simulation (with an associated update of model states) have been used. This is especially the case for water reservoirs and urban water networks. Only for open channels, most of the studies (>30 out of 58, with few studies with unclear information) test MPC with a different internal prediction model than the model used for the closed-loop simulation. Simplified versions of the Saint-Venant equations are usually used as an internal model in the MPC, while the full Saint-Venant equations, implemented in software solutions such as SOBEK (e.g., Fele et al., 2014; Hashemy Shahdany et al., 2017; Liu et al., 2023; Tian et al., 2019; van Overloop, Clemmens et al., 2010; Wahlin & Clemmens, 2006b) and SIC2 (e.g., Alvarez et al., 2013; Horvath et al., 2015a, 2015b; Pour et al., 2022; Segovia et al., 2019; van Overloop et al., 2014), are used as closed-loop simulation models. Using the same internal model for the closed-loop simulation is likely to lead to an overestimation of the MPC performance, but this is the solution adopted by many authors for two obvious reasons: (i) computation time reduction, and (ii) lack of more (refined) models readily available. For water reservoirs, only a few studies (e.g., Lin et al., 2020; Munier et al., 2015) have adopted a more refined and computationally-intensive model for the closed-loop simulation, which is essential to assess the robustness of the controller. Moreover, many studies, primarily on MPC applications in urban water networks, rely on simplified or synthetic systems (e.g., Sankar et al., 2015) due to the limited availability of calibrated high-fidelity models and the computational requirements of coupled hydraulic and water quality simulations of large-scale network systems models. While more computationally-efficient alternatives exist, including data-driven surrogate models (see Section 3.3), they often come with a tradeoff between computational savings and model accuracy. This should also be better quantified, possibly in relation to system size and characteristics.

Regarding the type of forecasts used in MPC (C3), various forecast variables, types and models emerge from the current literature, with differences depending on the type of water systems considered. In terms of forecasted variables, for water reservoirs, all the studies used either rainfall, inflow or tide forecasts. For urban water networks, water demand forecasts are mostly used, with a minority of studies also using rainfall/inflow or water levels. On the other hand, a more diverse set of forecasts are used for open channels, with more than half using water demand forecasts, less than half rainfall/inflow and a few other variables (see Table 1). In terms of the type of forecasts, for urban water networks, almost all the few studies relying on real (non-perfect) forecasts used statistical or ML-based models (e.g., Dong & Yang, 2019; Salvador, Munoz de la Pena, Ramirez, & Alamo, 2020). For open channels, six studies used statistical or ML-based models (e.g., Maestre et al., 2013; Tian, Negenborn et al., 2017b), five used process-based models (e.g., Aydin et al., 2019; Xu et al., 2013), and a single study used a hybrid approach (van Overloop et al., 2008). The picture is more complex for water reservoirs, for which the studies adopting real forecasts used more sources and forecasting techniques: less than half of them used well-established process-based hydrological models fed by operational meteorological forecasts (e.g., Ficchi et al., 2016; Raso et al., 2014; Wang et al., 2014) to produce the forecasts used in MPC, while slightly more than half used statistical or machine learning-based models that are calibrated on past observed data (e.g., Galelli et al., 2015; Gavahi et al., 2019; Giuliani & Castelletti, 2013; Pianosi & Soncini-Sessa, 2009). Only a few studies compared or integrated these two different techniques (Ahmad & Hussain, 2019; Wei & Xun, 2019). Given the recent increase in the availability of both real hydro-meteorological forecasts and efficient machine learning models, it is



logical to expect benefits from more testing of hybrid forecast products in MPC and further applications are needed. Along the same lines, also the availability of forecasts at multiple timescales has been increasing, from short-range (few days) to seasonal- or long-range (up to 6–7 months or a year), and there is growing interest in seamless forecasts (e.g., Wetterhall & Di Giuseppe, 2018). However, there is a lack of research integrating multiple forecast products across time scales in MPC. Moreover, there is a lack of research investigating the dependence of the optimal prediction horizon and relative MPC performance on the accuracy of forecasts. The optimal horizon and the MPC performance are expected to be intensely dependent on the quality of the forecasts (e.g., Payet-Burin et al., 2021; Wei & Xun, 2019), and this dependence is not trivial due to the receding horizon and on-line update of the control strategy.

Finally, a key point for multipurpose water systems is that only a limited number of studies explored possible Multi-Objective (MO) MPC frameworks (e.g., Lin et al., 2020) typically required to address the tradeoffs across sectors by providing a set of Pareto-optimal solutions (C4). The majority of the reviewed papers rather compute a weighted sum of the objectives (e.g., Dong & Yang, 2019; Tedesco et al., 2016), which aggregates multiple objectives in an individual objective function, and some authors reduce the number of objectives by enforcing more constraints in the control problem. Further work is needed to explore Pareto-optimal solutions from MPC both at each control time step and over a long simulation horizon rolled by multiple receding horizons to account for the multi-objective nature of water systems' operation problems and enable tradeoff analysis.

Lastly, we noticed that the level of detail in reporting model description, optimal control problem formulation and explanation of the proposed control/management methodology is heterogeneous across the collection of reviewed papers. In many cases, there is no sufficient level of detail in the reviewed journal articles to allow for a full and fair comparison. A final recommendation is thus to develop a standardized framework to report key information on the essential components of future MPC studies (e.g., type of forecasts, system size and state variables, implemented optimization method, benchmark methods, objective function, control variables, their number and their frequency) to facilitate comparison across studies, ultimately supporting knowledge transfer and reproducibility.

## 5. Conclusions

In recent years, Model Predictive Control has gained interest in the adaptive management of interconnected water resources systems, motivated by its capability of incorporating forecasts of evolving disturbances into a real-time optimal control scheme. Our comprehensive review of 149 peer-reviewed journal articles published in the last 25 years, selected after screening an originally more extensive set of 826 papers and checking them for eligibility, confirms an overall increasing adoption of MPC in all considered inter-connected sub-domains at the basin to urban scale, i.e., water reservoirs, open channels, and urban water networks. Despite the differences across these three types of systems, some common advantages, drawbacks, trends and challenges were identified in relation to MPC applications. In particular, our review identifies four main categories of challenges currently limiting most MPC applications in the water domain: (i) lack of systematic benchmarking of MPC with respect to other control methods and lack of assessment of the MPC performance in relation to the characteristics of the physical system; (ii) lack of assessment of the impact of uncertainties on the model-based control; (iii) limited analysis of the impact of diverse forecast types, resolutions, and prediction horizons; (iv) under-consideration of the multi-objective nature of most water resources systems. We argue that future MPC applications in water resources systems should focus on addressing these four challenges, as key priorities for future developments.

## Declaration of competing interest

The authors declare that they have no known competing financial interests or personal relationships that could have appeared to influence the work reported in this paper.

## Data availability

No data was used for the research described in the article.

## Acknowledgements

The authors thank the Guest Editor, Ahmad Taha, and three anonymous reviewers for the valuable comments which helped improve the manuscript.

## Funding

Andrea Castelletti, Andrea Ficchi, and Matteo Giuliani acknowledge support from the EU-funded Climate Intelligence (CLINT) project [grant number: 101003876; DOI: 10.3030/101003876]. Andrea Ficchi also acknowledges support from the AXA Research Fund Fellowship on Coastal Livelihoods. Wenyan Wu acknowledges support from the Australian Research Council via the Discovery Early Career Researcher Award [grant number: DE210100117].

## Appendix A. Supplementary data

Supplementary material related to this article can be found online at <https://doi.org/10.1016/j.arcontrol.2023.03.013>.

## References

- Abioye, E. A., Abidin, M. S. Z., Mahmud, M. S. A., Buyamin, S., Ishak, M. H. I., Rahman, M. K. I. A., et al. (2020). A review on monitoring and advanced control strategies for precision irrigation. *Computers and Electronics in Agriculture*, 173, Article 105441. <http://dx.doi.org/10.1016/j.compag.2020.105441>.
- Ahmad, S. K., & Hussain, F. (2019). A generic data-driven technique for forecasting of reservoir inflow: Application for hydropower maximization. *Environmental Modelling & Software*, 119, 147–165. <http://dx.doi.org/10.1016/j.envsoft.2019.06.008>.
- Alvarez, A., Ridao, M. A., Ramirez, D. R., & Sanchez, L. (2013). Constrained predictive control of an irrigation canal. *Journal of Irrigation and Drainage Engineering*, 139(10), 841–854. [http://dx.doi.org/10.1061/\(ASCE\)IR.1943-4774.0000619](http://dx.doi.org/10.1061/(ASCE)IR.1943-4774.0000619).
- Anand, A., Galelli, S., Samavedham, L., & Sundaramoorthy, S. (2013). Coordinating multiple model predictive controllers for the management of large-scale water systems. *Journal of Hydroinformatics*, 15(2), 293–305. <http://dx.doi.org/10.2166/hydro.2012.173>.
- Anghileri, D., Voisin, N., Castelletti, A., Pianosi, F., Nijssen, B., & Lettenmaier, D. P. (2016). Value of long-term streamflow forecasts to reservoir operations for water supply in snow-dominated river catchments. *Water Resources Research*, 52(6), 4209–4225. <http://dx.doi.org/10.1002/2015WR017864>.
- Arsenault, R., & Cote, P. (2019). Analysis of the effects of biases in ensemble streamflow prediction (ESP) forecasts on electricity production in hydropower reservoir management. *Hydrology and Earth System Sciences*, 23(6), 2735–2750. <http://dx.doi.org/10.5194/hess-23-2735-2019>.
- Askari Fard, A., Hashemy Shahdany, S. M., Javadi, S., & Maestre, J. M. (2022). Developing an automatic conjunctive surface-groundwater operating system for sustainable agricultural water distribution. *Computers and Electronics in Agriculture*, 194, Article 106774. <http://dx.doi.org/10.1016/j.compag.2022.106774>.
- Avargani, H. K., Hashemy Shahdany, S. M., Kamrani, K., Maestre, J. M., Hashemi Garmdareh, S. E., & Liaghat, A. (2022). Prioritization of surface water distribution in irrigation districts to mitigate crop yield reduction during water scarcity. *Agricultural Water Management*, 269, Article 107653. <http://dx.doi.org/10.1016/j.agwat.2022.107653>.
- Aydin, B. E., Essink, G. H. P. O., Delsman, J. R., van de Giesen, N., & Abraham, E. (2022). Nonlinear model predictive control of salinity and water level in polder networks: Case study of Lissertocht catchment. *Agricultural Water Management*, 264, <http://dx.doi.org/10.1016/j.agwat.2022.107502>.
- Aydin, B. E., van Overloop, P. J., Rutten, M., & Tian, X. (2017). Offset-free model predictive control of an open water channel based on moving horizon estimation. *Journal of Irrigation and Drainage Engineering*, 143(3, SI), [http://dx.doi.org/10.1061/\(ASCE\)IR.1943-4774.0001085](http://dx.doi.org/10.1061/(ASCE)IR.1943-4774.0001085).

- Aydin, B. E., Tian, X., Delsman, J., Essink, G. H. P. O., Rutten, M., & Abraham, E. (2019). Optimal salinity and water level control of water courses using Model Predictive Control. *Environmental Modelling & Software*, 112, 36–45. <http://dx.doi.org/10.1016/j.envsoft.2018.11.010>.
- Baardman, L., Cristian, R., Perakis, G., Singhvi, D., Skali Lami, O., & Thayaparan, L. (2022). The role of optimization in some recent advances in data-driven decision-making. *Mathematical Programming*, <http://dx.doi.org/10.1007/s10107-022-01874-9>.
- Bakker, M., Vreeburg, J., Palmen, L., Sperber, V., Bakker, G., & Rietveld, L. (2013). Better water quality and higher energy efficiency by using model predictive flow control at water supply systems. *Journal of Water Supply: Research and Technology-AQUA*, 62(1), 1–13.
- Balla, K., Bendtsen, J., Kallesøe, C., & Ocampo-Martinez, C. (2022). A learning-based approach towards the data-driven control of wastewater networks – An experimental case study. *Water Research*, 221, Article 118782. <http://dx.doi.org/10.1016/j.watres.2022.118782>.
- Barreiro-Gomez, J., Ocampo-Martinez, C., & Quijano, N. (2017). Dynamical tuning for multi-objective model predictive control based on population games. *ISA Transactions*, 69, 175–186. <http://dx.doi.org/10.1016/j.isatra.2017.03.027>.
- Barreiro-Gomez, J., Ocampo-Martinez, C., & Quijano, N. (2019). Time-varying partitioning for predictive control design: Density-Games Approach. *Journal of Process Control*, 75, 1–14. <http://dx.doi.org/10.1016/j.jprocont.2018.12.011>.
- Barreiro-Gomez, J., Ocampo-Martinez, C., Quijano, N., & Maestre, J. (2017). Non-centralized control for flow-based distribution networks: A game-theoretical insight. *Journal of the Franklin Institute*, 354(14), 5771–5796. <http://dx.doi.org/10.1016/j.franklin.2017.06.021>.
- Barreiro-Gomez, J., Quijano, N., & Ocampo-Martinez, C. (2016). Constrained distributed optimization: A population dynamics approach. *Automatica*, 69, 101–116. <http://dx.doi.org/10.1016/j.automatica.2016.02.004>.
- Bellman, R. (1957). *Dynamic programming*. Princeton: Princeton University Press.
- Bertsekas, D. (1976). *Dynamic programming and stochastic control*. New York: Academic Press.
- Bertsekas, D. P. (2005). Dynamic Programming and Suboptimal Control: A Survey from ADP to MPC\*. *European Journal of Control*, 11(4), 310–334. <http://dx.doi.org/10.3166/ejc.11.310-334>, URL <https://www.sciencedirect.com/science/article/pii/S0947358005710402>.
- Bierkens, M. F. P., Bell, V. A., Burek, P., Chaney, N., Condon, L. E., David, C. H., et al. (2015). Hyper-resolution global hydrological modelling: what is next? *Hydrological Processes*, 29(2), 310–320. <http://dx.doi.org/10.1002/hyp.10391>, URL <https://onlinelibrary.wiley.com/doi/abs/10.1002/hyp.10391>, eprint: <https://onlinelibrary.wiley.com/doi/pdf/10.1002/hyp.10391>.
- Biscos, C., Mulholland, M., Le Lann, M.-V., Brouckaert, C., Bailey, R., & Roustan, M. (2002). Optimal operation of a potable water distribution network. *Water Science and Technology*, 46(9), 155–162.
- Biscos, C., Mulholland, M., Le Lann, M., Buckley, C., & Brouckaert, C. (2003). Optimal operation of water distribution networks by predictive control using MINLP. *Water Sa*, 29(4), 393–404.
- Blair, G. S., Beven, K., Lamb, R., Bassett, R., Cauwenberghs, K., Hankin, B., et al. (2019). Models of everywhere revisited: A technological perspective. *Environmental Modelling & Software*, 122, Article 104521. <http://dx.doi.org/10.1016/j.envsoft.2019.104521>, URL <https://www.sciencedirect.com/science/article/pii/S1364815218303773>.
- Blanco, T. B., Willems, P., Chiang, P.-K., Haverbeke, N., Berlamont, J., & De Moor, B. (2010). Flood regulation using nonlinear model predictive control. *Control Engineering Practice*, 18(10), 1147–1157. <http://dx.doi.org/10.1016/j.conengprac.2010.06.005>.
- Boretti, A., & Rosa, L. (2019). Reassessing the projections of the World Water Development Report. *Npj Clean Water*, 2(1), 15. <http://dx.doi.org/10.1038/s41545-019-0039-9>.
- Brears, R. C. (2018). *Palgrave Studies in Climate Resilient Societies, Climate resilient Water Resources Management*. Berlin: Palgrave Pivot Cham. Springer, URL.
- Breckpot, M., Agudelo, O. M., & De Moor, B. (2013). Flood control with model predictive control for river systems with water reservoirs. *Journal of Irrigation and Drainage Engineering*, 139(7), 532–541. [http://dx.doi.org/10.1061/\(ASCE\)JIR.1943-4774.0000577](http://dx.doi.org/10.1061/(ASCE)JIR.1943-4774.0000577).
- Buizza, R. (2019). Introduction to the special issue on “25 years of ensemble forecasting”. *Quarterly Journal of the Royal Meteorological Society*, 145(S1), 1–11. <http://dx.doi.org/10.1002/qj.3370>, URL <https://rmets.onlinelibrary.wiley.com/doi/abs/10.1002/qj.3370>, eprint: <https://rmets.onlinelibrary.wiley.com/doi/pdf/10.1002/qj.3370>.
- Bwambale, E., Abagale, F. K., & Anornu, G. K. (2022). Smart irrigation monitoring and control strategies for improving water use efficiency in precision agriculture: A review. *Agricultural Water Management*, 260, Article 107324. <http://dx.doi.org/10.1016/j.agwat.2021.107324>.
- Calafiore, G., & Campi, M. (2006). The scenario approach to robust control design. *IEEE Transactions on Automatic Control*, 51(5), 742–753. <http://dx.doi.org/10.1109/TAC.2006.875041>.
- Calafiore, G. C., & Fagiano, L. (2013a). Robust model predictive control via scenario optimization. *IEEE Transactions on Automatic Control*, 58(1), 219–224. <http://dx.doi.org/10.1109/TAC.2012.2203054>.
- Calafiore, G. C., & Fagiano, L. (2013b). Stochastic model predictive control of LPV systems via scenario optimization. *Automatica*, 49(6), 1861–1866. <http://dx.doi.org/10.1016/j.automatica.2013.02.060>.
- Camporese, M., & Girotto, M. (2022). Recent advances and opportunities in data assimilation for physics-based hydrological modeling. *Frontiers in Water*, 4, URL <https://www.frontiersin.org/articles/10.3389/frwa.2022.948832>.
- Castelletti, A., Pianosi, F., & Soncini-Sessa, R. (2008a). Receding horizon control for water resources management. *Applied Mathematics and Computation*, 204(2), 621–631. <http://dx.doi.org/10.1016/j.amc.2008.05.044>.
- Castelletti, A., Pianosi, F., & Soncini-Sessa, R. (2008b). Water reservoir control under economic, social and environmental constraints. *Stochastic Modelling, Control, and Robust Optimization at the Crossroads of Engineering, Environmental Economics, and Finance*, 44(6), 1595–1607. <http://dx.doi.org/10.1016/j.automatica.2008.03.003>, URL <https://www.sciencedirect.com/science/article/pii/S0005109808001271>.
- Cembrano, G., Quevedo, J., Puig, V., Pérez, R., Figueras, J., Verdejo, J., et al. (2011). PLIO: a generic tool for real-time operational predictive optimal control of water networks. *Water Science and Technology*, 64(2), 448–459.
- Chakraborty, D., Başağaoğlu, H., & Winterle, J. (2021). Interpretable vs. noninterpretable machine learning models for data-driven hydro-climatological process modeling. *Expert Systems with Applications*, 170, Article 114498. <http://dx.doi.org/10.1016/j.eswa.2020.114498>, URL <https://www.sciencedirect.com/science/article/pii/S0957417420311428>.
- Chen, W.-H., Shang, C., Zhu, S., Haldeman, K., Santiago, M., Stroock, A. D., et al. (2021). Data-driven Robust model predictive control framework for stem water potential regulation and irrigation in water management. *Control Engineering Practice*, 113, Article 104841. <http://dx.doi.org/10.1016/j.conengprac.2021.104841>.
- Chen, W.-H., & You, F. (2021). Smart greenhouse control under harsh climate conditions based on data-driven Robust model predictive control with principal component analysis and kernel density estimation. *Journal of Process Control*, 107, 103–113. <http://dx.doi.org/10.1016/j.jprocont.2021.10.004>.
- Coelho, B., & Andrade-Campos, A. (2014). Efficiency achievement in water supply systems—A review. *Renewable and Sustainable Energy Reviews*, 30, 59–84.
- Conde, G., Quijano, N., & Ocampo-Martinez, C. (2021). Modeling and control in open-channel irrigation systems: A review. *Annual Reviews in Control*, 51, 153–171. <http://dx.doi.org/10.1016/j.arcontrol.2021.01.003>.
- Creaco, E., Campisano, A., Fontana, N., Marini, G., Page, P., & Walski, T. (2019). Real time control of water distribution networks: A state-of-the-art review. *Water Research*, 161, 517–530.
- Şen, Z. (2021). Reservoirs for Water Supply Under Climate Change Impact—A Review. *Water Resources Management*, 35(11), 3827–3843. <http://dx.doi.org/10.1007/s11269-021-02925-0>.
- Cuvellier, T., Archambeau, P., Dewals, B., & Louveaux, Q. (2018). Comparison Between Robust and Stochastic Optimisation for Long-term Reservoir Management Under Uncertainty. *Water Resources Management*, 32(5), 1599–1614. <http://dx.doi.org/10.1007/s11269-017-1893-1>.
- Darsono, S., & Labadie, J. W. (2007). Neural-optimal control algorithm for real-time regulation of in-line storage in combined sewer systems. *Environmental Modelling & Software*, 22(9), 1349–1361.
- Delgoda, D. K., Saleem, S. K., Halgamuge, M. N., & Malano, H. (2013). Multiple Model Predictive Flood Control in Regulated River Systems with Uncertain Inflows. *Water Resources Management*, 27(3), 765–790. <http://dx.doi.org/10.1007/s11269-012-0214-y>.
- Ding, Y., Wang, L., Li, Y., & Li, D. (2018). Model predictive control and its application in agriculture: A review. *Computers and Electronics in Agriculture*, 151, 104–117. <http://dx.doi.org/10.1016/j.compag.2018.06.004>.
- Doan, M. D., Giselsson, P., Keviczky, T., De Schutter, B., & Rantzer, A. (2013). A distributed accelerated gradient algorithm for distributed model predictive control of a hydro power valley. *Control Engineering Practice*, 21(11), 1594–1605. <http://dx.doi.org/10.1016/j.conengprac.2013.06.012>.
- Dobson, B., Wagener, T., & Pianosi, F. (2019). An argument-driven classification and comparison of reservoir operation optimization methods. *Advances in Water Resources*, 128, 74–86. <http://dx.doi.org/10.1016/j.advwatres.2019.04.012>, URL <https://www.sciencedirect.com/science/article/pii/S0309170818307759>.
- Dong, W., & Yang, Q. (2019). Data-driven solution for optimal pumping units scheduling of smart water conservancy. *IEEE Internet of Things Journal*, 7(3), 1919–1926.
- El Ghazouli, K., El Khatabi, J., Souhli, A., & Shahrour, I. (2022). Model predictive control based on artificial intelligence and EPA-SWMM model to reduce CSOs impacts in sewer systems. *Water Science and Technology*, 85(1), 398–408.
- Fan, F. M., Schwannenberg, D., Alvarado, R., dos Reis, A. A., Collischonn, W., & Naumann, S. (2016). Performance of Deterministic and Probabilistic Hydrological Forecasts for the Short-Term Optimization of a Tropical Hydropower Reservoir. *Water Resources Management*, 30(10), 3609–3625. <http://dx.doi.org/10.1007/s11269-016-1377-8>.
- Farhadi, A., & Khodabandehlou, A. (2016). Distributed model predictive control with hierarchical architecture for communication: application in automated irrigation channels. *International Journal of Control*, 89(8), 1725–1741. <http://dx.doi.org/10.1080/00207179.2016.1145358>.
- Fele, F., Maestre, J. M., Hashemy, S. M., Muñoz de la Peña, D., & Camacho, E. F. (2014). Coalitional model predictive control of an irrigation canal. *Journal of Process Control*, 24(4), 314–325. <http://dx.doi.org/10.1016/j.jprocont.2014.02.005>.

- Ficchi, A., Raso, L., Dorchies, D., Pianosi, F., Malaterre, P. O., Van Overloop, P. J., et al. (2016). Optimal Operation of the Multireservoir System in the Seine River Basin Using Deterministic and Ensemble Forecasts. *Journal of Water Resources Planning and Management*, 142(1), [http://dx.doi.org/10.1061/\(ASCE\)WR.1943-5452.0000571](http://dx.doi.org/10.1061/(ASCE)WR.1943-5452.0000571).
- Fiedler, F., Cominola, A., & Lucia, S. (2020). Economic nonlinear predictive control of water distribution networks based on surrogate modeling and automatic clustering. *IFAC-PapersOnLine*, 53(2), 16636–16643.
- Figueiredo, J., Botto, M. A., & Rijo, M. (2013). SCADA system with predictive controller applied to irrigation canals. *Control Engineering Practice*, 21(6), 870–886. <http://dx.doi.org/10.1016/j.conengprac.2013.01.008>.
- Fiorelli, D., Schutz, G., Metla, N., & Meyers, J. (2013). Application of an optimal predictive controller for a small water distribution network in Luxembourg. *Journal of Hydroinformatics*, 15(3), 625–633.
- Foo, M., Ooi, S. K., & Weyer, E. (2014). System identification and control of the Broken River. *IEEE Transactions on Control Systems Technology*, 22(2), 618–634. <http://dx.doi.org/10.1109/TCST.2013.2253103>.
- Forbes, M. G., Patwardhan, R. S., Hamadah, H., & Gopaluni, R. B. (2015). Model Predictive Control in Industry: Challenges and Opportunities. *IFAC-PapersOnLine*, 48(8), 531–538. <http://dx.doi.org/10.1016/j.ifacol.2015.09.022>, URL <https://www.sciencedirect.com/science/article/pii/S2405896315011039>.
- Galelli, S., Castelletti, A., & Goedbloed, A. (2015). High-Performance Integrated Control of water quality and quantity in urban water reservoirs. *Water Resources Research*, 51(11), 9053–9072. <http://dx.doi.org/10.1002/2015WR017595>.
- Galelli, S., Goedbloed, A., Schwanenberg, D., & van Overloop, P.-J. (2014). Optimal Real-Time Operation of Multipurpose Urban Reservoirs: Case Study in Singapore. *Journal of Water Resources Planning and Management*, 140(4), 511–523. [http://dx.doi.org/10.1061/\(ASCE\)WR.1943-5452.0000342](http://dx.doi.org/10.1061/(ASCE)WR.1943-5452.0000342).
- García, L., Barreiro-Gomez, J., Escobar, E., Téllez, D., Quijano, N., & Ocampo-Martinez, C. (2015). Modeling and real-time control of urban drainage systems: A review. *Advances in Water Resources*, 85, 120–132. <http://dx.doi.org/10.1016/j.advwatres.2015.08.007>.
- Gavahi, K., Mousavi, S. J., & Ponnambalam, K. (2019). Adaptive forecast-based real-time optimal reservoir operations: application to Lake Urmia. *Journal of Hydroinformatics*, 21(5), 908–924. <http://dx.doi.org/10.2166/hydro.2019.005>.
- Giuliani, M., & Castelletti, A. (2013). Assessing the value of cooperation and information exchange in large water resources systems by agent-based optimization. *Water Resources Research*, 49(7), 3912–3926. <http://dx.doi.org/10.1002/wrcr.20287>, URL <https://agupubs.onlinelibrary.wiley.com/doi/abs/10.1002/wrcr.20287> eprint: <https://agupubs.onlinelibrary.wiley.com/doi/pdf/10.1002/wrcr.20287>.
- Giuliani, M., Galelli, S., & Soncini-Sessa, R. (2014). A dimensionality reduction approach for Many-Objective Markov Decision Processes: application to a water reservoir operation problem. *Environmental Modeling & Software*, 57, 101–114. <http://dx.doi.org/10.1016/j.envsoft.2014.02.011>.
- Giuliani, M., Herman, J., Castelletti, A., & Reed, P. (2014). Many-objective reservoir policy identification and refinement to reduce policy inertia and myopia in water management. *Water Resources Research*, 50, 3355–3377. <http://dx.doi.org/10.1002/2013WR014700>.
- Giuliani, M., Lamontagne, J. R., Reed, P. M., & Castelletti, A. (2021). A State-of-the-Art Review of Optimal Reservoir Control for Managing Conflicting Demands in a Changing World. *Water Resources Research*, 57(12), <http://dx.doi.org/10.1029/2021WR029927>.
- Giuliani, M., Li, Y., Cominola, A., Denaro, S., Mason, E., & Castelletti, A. (2016). A Matlab toolbox for designing Multi-Objective Optimal Operations of water reservoir systems. *Environmental Modelling & Software*, 85, 293–298. <http://dx.doi.org/10.1016/j.envsoft.2016.08.015>.
- Global Water Partnership - GWP (2021). *Perspectives Papers: vol. 13, Storing water: A new integrated approach for resilient development*. (13), Stockholm: GWP Secretariat.
- Gneiting, T., & Raftery, A. E. (2005). Weather Forecasting with Ensemble Methods. *Science*, 310(5746), 248–249. <http://dx.doi.org/10.1126/science.1115255>, URL <https://www.science.org/doi/abs/10.1126/science.1115255> eprint: <https://www.science.org/doi/pdf/10.1126/science.1115255>.
- Grosso, J., Ocampo-Martinez, C., Puig, V., & Joseph, B. (2014). Chance-constrained model predictive control for drinking water networks. *Journal of Process Control*, 24(5), 504–516.
- Grosso, J. M., Ocampo-Martinez, C., & Puig Cayuela, V. (2016). Reliability-based economic model predictive control for generalized flow-based networks including actuators' health-aware capabilities. *International Journal of Applied Mathematics and Computer Science*, 26(3), 641–654.
- Grosso, J. M., Velarde, P., Ocampo-Martinez, C., Maestre, J. M., & Puig, V. (2017). Stochastic model predictive control approaches applied to drinking water networks. *Optimal Control Applications and Methods*, 38(4), 541–558.
- Gründemann, G. J., van de Giesen, N., Brunner, L., & van der Ent, R. (2022). Rarest rainfall events will see the greatest relative increase in magnitude under future climate change. *Commun. Earth Environ.*, 3(1), 235. <http://dx.doi.org/10.1038/s43247-022-00558-8>.
- Guo, Y., Wang, S., Taha, A. F., & Summers, T. H. (2022). Optimal pump control for water distribution networks via data-based distributional robustness. *IEEE Transactions on Control Systems Technology*.
- Hall, J. W., Grey, D., Garrick, D., Fung, F., Brown, C., Dadson, S. J., et al. (2014). Coping with the curse of freshwater variability. *Science*, 346(6208), 429–430. <http://dx.doi.org/10.1126/science.1257890>, URL <https://www.science.org/doi/abs/10.1126/science.1257890> eprint: <https://www.science.org/doi/pdf/10.1126/science.1257890>.
- Hashemy, S. M., Monem, M. J., Maestre, J. M., & Van Overloop, P. J. (2013). Application of an in-line storage strategy to improve the operational performance of main irrigation canals using model predictive control. *Journal of Irrigation and Drainage Engineering*, 139(8), 635–644. [http://dx.doi.org/10.1061/\(ASCE\)IR.1943-4774.0000603](http://dx.doi.org/10.1061/(ASCE)IR.1943-4774.0000603).
- Hashemy Shahdany, S. M., Hasani, Y., Majidi, Y., & Maestre, J. M. (2017). Modern operation of main irrigation canals suffering from water scarcity based on an economic perspective. *Journal of Irrigation and Drainage Engineering*, 143(3), B4016001. [http://dx.doi.org/10.1061/\(ASCE\)IR.1943-4774.0001024](http://dx.doi.org/10.1061/(ASCE)IR.1943-4774.0001024).
- Hirsch, C. (2007). *Numerical computation of internal and external flows: The fundamentals of computational fluid dynamics*. Elsevier.
- Horvath, K., Galvis, E., Gomez Valentin, M., & Rodellar, J. (2015a). New offset-free method for model predictive control of open channels. *Control Engineering Practice*, 41, 13–25. <http://dx.doi.org/10.1016/j.conengprac.2015.04.002>.
- Horvath, K., Galvis, E., Gomez Valentin, M., & Rodellar Benede, J. (2015b). Is it better to use gate opening as control variable than discharge to control irrigation canals? *Journal of Irrigation and Drainage Engineering*, 141(3), [http://dx.doi.org/10.1061/\(ASCE\)IR.1943-4774.0000798](http://dx.doi.org/10.1061/(ASCE)IR.1943-4774.0000798).
- Horvath, K., van Esch, B., Vreeken, T., Piovesan, T., Talsma, J., & Pothof, I. (2022). Potential of model predictive control of a polder water system including pumps, weirs and gates. *Journal of Process Control*, 119, 128–140. <http://dx.doi.org/10.1016/j.jprocont.2022.10.003>.
- Housh, M., & Salomons, E. (2019). Optimal dynamic pump triggers for cost saving and robust water distribution system operations. *Journal of Water Resources Planning and Management*, 145(2), 04018095.
- Huang, R., Ma, C., Ma, J., Huangfu, X., & He, Q. (2021). Machine learning in natural and engineered water systems. *Water Research*, 205, Article 117666. <http://dx.doi.org/10.1016/j.watres.2021.117666>, URL <https://www.sciencedirect.com/science/article/pii/S0043135421008617>.
- IPCC (2021). In V. Masson-Delmotte, P. Zhai, A. Pirani, S. Connors, C. Péan, S. Berger, N. Caud, Y. Chen, L. Goldfarb, M. Gomis, M. Huang, K. Leitzell, E. Lonnoy, J. Matthews, T. Maycock, T. Waterfield, O. Yelekçi, R. Yu, & B. Zhou (Eds.), *Summary for policymakers. in: Climate change 2021: the physical science basis. contribution of working group I to the sixth assessment report of the intergovernmental panel on climate change* (Cambridge University Press, Cambridge, United Kingdom and New York, NY, USA), Cambridge, UK, and New York, NY, USA: Cambridge University Press, <http://dx.doi.org/10.1017/9781009157896.001>.
- Javan Salehi, M., & Shourian, M. (2021). Comparative Application of Model Predictive Control and Particle Swarm Optimization in Optimum Operation of a Large-Scale Water Transfer System. *Water Resources Management*, 35(2), 707–727. <http://dx.doi.org/10.1007/s11269-020-02755-6>.
- Joseph-Duran, B., Jung, M. N., Ocampo-Martinez, C., Sager, S., & Cembrano, G. (2014a). Minimization of sewage network overflow. *Water Resources Management*, 28, 41–63.
- Joseph-Duran, B., Ocampo-Martinez, C., & Cembrano, G. (2014b). Hybrid modeling and receding horizon control of sewer networks. *Water Resources Research*, 50(11), 8497–8514.
- Joseph-Duran, B., Ocampo-Martinez, C., & Cembrano, G. (2015). Output-feedback control of combined sewer networks through receding horizon control with moving horizon estimation. *Water Resources Research*, 51(10), 8129–8145.
- Kändler, N., Annus, I., & Vassiljev, A. (2022). Controlling peak runoff from plots by coupling street storage with distributed real time control. *Urban Water Journal*, 19(1), 97–108.
- Karimanzira, D., Schwanenberg, D., Allen, C., & Barton, S. (2016). Short-Term Hydropower Optimization and Assessment of Operational Flexibility. *Journal of Water Resources Planning and Management*, 142(2), Article 04015048. [http://dx.doi.org/10.1061/\(ASCE\)WR.1943-5452.0000577](http://dx.doi.org/10.1061/(ASCE)WR.1943-5452.0000577), URL <https://ascelibrary.org/doi/abs/10.1061/%28ASCE%29WR.1943-5452.0000577> eprint: <https://ascelibrary.org/doi/pdf/10.1061/%28ASCE%29WR.1943-5452.0000577>.
- Kergus, P., Formentin, S., Giuliani, M., & Castelletti, A. (2022). Learning-based hierarchical control of water reservoir systems. *IFAC Journal of Systems and Control*, 19, <http://dx.doi.org/10.1016/j.ifacsc.2022.100185>.
- Kistenmacher, M., & Georgakakos, A. P. (2015). Assessment of reservoir system variable forecasts. *Water Resources Research*, 51(5), 3437–3458. <http://dx.doi.org/10.1002/2014WR016564>.
- Kong, L., Lei, X., Wang, H., Long, Y., Lu, L., & Yang, Q. (2019). A model predictive water-level difference control method for automatic control of irrigation canals. *Water*, 11(4), <http://dx.doi.org/10.3390/w11040762>.
- Kong, L., Quan, J., Yang, Q., Song, P., & Zhu, J. (2019). Automatic control of the Middle Route project for South-to-North water transfer based on linear model predictive control algorithm. *Water*, 11(9), <http://dx.doi.org/10.3390/w11091873>.
- Kong, L., Song, P., Ji, Q., Zhu, S., & Li, J. (2021). Water level predictive control in multi-cascade pools with large control interval demand based on constraint methods. *Journal of Hydrology*, 603(C), <http://dx.doi.org/10.1016/j.jhydrol.2021.127024>.



- Labadie, J. W. (2004). Optimal Operation of Multireservoir Systems: State-of-the-Art Review. *Journal of Water Resources Planning and Management*, 130(2), 93–111. [http://dx.doi.org/10.1061/\(ASCE\)0733-9496\(2004\)130:2\(93\)](http://dx.doi.org/10.1061/(ASCE)0733-9496(2004)130:2(93)), URL [https://ascelibrary.org/doi/abs/10.1061/\(ASCE\)0733-9496%282004%29130%3A2%2893%29](https://ascelibrary.org/doi/abs/10.1061/(ASCE)0733-9496%282004%29130%3A2%2893%29), eprint: [https://ascelibrary.org/doi/pdf/10.1061/\(ASCE\)0733-9496%282004%29130%3A2%2893%29](https://ascelibrary.org/doi/pdf/10.1061/(ASCE)0733-9496%282004%29130%3A2%2893%29).
- Lemos, J. M., Machado, F., Nogueira, N., Rato, L., & Rijo, M. (2009). Adaptive and non-adaptive model predictive control of an irrigation channel. *Networks and Heterogeneous Media*, 4(2, SI), 303–324. <http://dx.doi.org/10.3934/nhm.2009.4.303>.
- Leviex, L., Ocampo-Martinez, C., Inthamoussou, F., & De Battista, H. (2021). Predictive management approach for the coordination of wind and water-based power supplies. *Energy*, 219, Article 119535. <http://dx.doi.org/10.1016/j.energy.2020.119535>.
- Limon, D., Pereira, M., De La Peña, D. M., Alamo, T., & Grosso, J. M. (2014). Single-layer economic model predictive control for periodic operation. *Journal of Process Control*, 24(8), 1207–1224.
- Lin, N. M., Rutten, M., & Tian, X. (2018). Flood Mitigation through Optimal Operation of a Multi-Reservoir System by Using Model Predictive Control: A Case Study in Myanmar. *Water*, 10(10), <http://dx.doi.org/10.3390/w10101371>.
- Lin, N. M., Tian, X., Rutten, M., Abraham, E., Maestre, J. M., & van de Giesen, N. (2020). Multi-Objective Model Predictive Control for Real-Time Operation of a Multi-Reservoir System. *WATER*, 12(7), <http://dx.doi.org/10.3390/w12071898>.
- Litrico, X., & Fromion, V. (2004). Analytical approximation of open-channel flow for controller design. *Applied Mathematical Modelling*, 28(7), 677–695.
- Litrico, X., & Fromion, V. (2009). *Modeling and control of hydrosystems*. Springer Science & Business Media.
- Liu, J., Wang, Z., Yang, Z., & Zhang, T. (2023). An adaptive predictive control algorithm for comprehensive dendritic canal systems. *Journal of Irrigation and Drainage Engineering*, 149(1), Article 04022046. [http://dx.doi.org/10.1061/\(ASCE\)IR.1943-4774.0001736](http://dx.doi.org/10.1061/(ASCE)IR.1943-4774.0001736).
- Liu, D., Zheng, Y., Wu, J., & Li, S. (2020). Zone model predictive control for pressure management of water distribution network. *Asian Journal of Control*, 22(4), 1522–1536.
- Loucks, D. P., & Van Beek, E. (2017). *Water resource systems planning and management: An introduction to methods, models, and applications*. Springer.
- Lucia, S., Finkler, T., & Engell, S. (2013). Multi-stage nonlinear model predictive control applied to a semi-batch polymerization reactor under uncertainty. *Journal of Process Control*, 23(9), 1306–1319.
- Lund, N. S. V., Falk, A. K. V., Borup, M., Madsen, H., & Steen Mikkelsen, P. (2018). Model predictive control of urban drainage systems: a review and perspective towards smart real-time water management. *Critical Reviews in Environmental Science and Technology*, 48(3), 279–339.
- Maass, A., Hufschmidt, M. M., Dorfman, R., Thomas, H. A., Jr., Marglin, S. A., & Fair, G. M. (1962). *Design of water-resource systems: New techniques for relating economic objectives, engineering analysis, and governmental planning*. Cambridge, MA and London, England: Harvard University Press, <http://dx.doi.org/10.4159/harvard.9780674421042>.
- Macian-Sorribes, H., & Pulido-Velazquez, M. (2020). Inferring efficient operating rules in multireservoir water resource systems: A review. *Wiley Interdisciplinary Reviews-Water*, 7(1), <http://dx.doi.org/10.1002/wat2.1400>.
- Maestre, J. M., Raso, L., van Overloop, P. J., & De Schutter, B. (2013). Distributed tree-based model predictive control on a drainage water system. *Journal of Hydroinformatics*, 15(2), 335–347. <http://dx.doi.org/10.2166/hydro.2012.125>.
- Mala-Jetmarova, H., Sultanova, N., & Savic, D. (2017). Lost in optimisation of water distribution systems? A literature review of system operation. *Environmental Modelling & Software*, 93, 209–254.
- Malaterre, P. O. (1995). Regulation of irrigation canals. *Irrigation and Drainage Systems*, 9(4), 297–327. <http://dx.doi.org/10.1007/bf00881619>.
- Malaterre, P. O., Rogers, D. C., & Schuurmans, J. (1998). Classification of canal control algorithms. *Journal of Irrigation and Drainage Engineering*, 124(1), 3–10.
- Mareels, I., Weyer, E., Ooi, S. K., Cantoni, M., Li, Y., & Nair, G. (2005). Systems engineering for irrigation systems: Successes and challenges. *Annual Reviews in Control*, 29(2), 191–204. <http://dx.doi.org/10.1016/j.arcontrol.2005.08.001>.
- Marinaki, M., Papageorgiou, M., & Messmer, A. (1999). Multivariable regulator approach to sewer network flow control. *Journal of Environmental Engineering*, 125(3), 267–276.
- Martin, A., Delgado-Aguinaga, J., & Puig, V. (2022). Control of transients in drinking water networks. *Control Engineering Practice*, 119, Article 104986.
- Martínez, F., Hernández, V., Alonso, J. M., Rao, Z., & Alvisi, S. (2007). Optimizing the operation of the valencia water-distribution network. *Journal of Hydroinformatics*, 9(1), 65–78.
- Mesbah, A. (2016). Stochastic model predictive control: An overview and perspectives for future research. *IEEE Control Systems Magazine*, 36(6), 30–44. <http://dx.doi.org/10.1109/MCS.2016.2602087>.
- Mirallas-Wilhelm, F. (2022). Water is the middle child in global climate policy. *Nature Climate Change*, 12(2), 110–112. <http://dx.doi.org/10.1038/s41558-021-01154-y>.
- Miro, M. E., Groves, D., Tincher, B., Syme, J., Tanverakul, S., & Catt, D. (2021). Adaptive water management in the face of uncertainty: Integrating machine learning, groundwater modeling and robust decision making. *Climate Risk Management*, 34, Article 100383. <http://dx.doi.org/10.1016/j.crm.2021.100383>, URL <https://www.sciencedirect.com/science/article/pii/S2212096321001121>.
- Mohanavelu, A., Soundharajan, B.-S., & Kisi, O. (2022). Modeling Multi-objective Pareto-optimal Reservoir Operation Policies Using State-of-the-art Modeling Techniques. *Water Resources Management*, 36(9), 3107–3128. <http://dx.doi.org/10.1007/s11269-022-03191-4>.
- Moher, D., Liberati, A., Tetzlaff, J., Altman, D. G., & PRISMA Group\* (2009). Preferred reporting items for systematic reviews and meta-analyses: the PRISMA statement. *Annals of Internal Medicine*, 151(4), 264–269.
- Munier, S., Polebistki, A., Brown, C., Belaud, G., & Lettenmaier, D. P. (2015). SWOT data assimilation for operational reservoir management on the upper Niger River Basin. *Water Resources Research*, 51(1), 554–575. <http://dx.doi.org/10.1002/2014WR016157>.
- Muros, F., Maestre, J., Ocampo-Martinez, C., Algaba, E., & Camacho, E. (2018). A game theoretical randomized method for large-scale systems partitioning. *IEEE Access*, 6(1), 42245–42263. <http://dx.doi.org/10.1109/ACCESS.2018.2854783>.
- Muslim, A., Li, Q., & Tade, M. O. (2008). Simultaneous model of chlorine dosing and decay in drinking water distribution system and model predictive control application. *Asia-Pacific Journal of Chemical Engineering*, 3(6), 613–621.
- Nair, S. S., McManamay, R. A., Derolph, C. R., & Allen-Dumas, M. (2020). Methods for integrating high-resolution land, climate, and infrastructure scenarios in a hydrologic simulation model. *MethodsX*, 7, Article 100699. <http://dx.doi.org/10.1016/j.mex.2019.10.010>, URL <https://www.sciencedirect.com/science/article/pii/S2215016119302754>.
- Nasir, H. A., Cantoni, M., Li, Y., & Weyer, E. (2021). Stochastic model predictive control based reference planning for automated open-water channels. *IEEE Transactions on Control Systems Technology*, 29(2), 607–619. <http://dx.doi.org/10.1109/TCST.2019.2952788>.
- Negenborn, R. R., van Overloop, P. J., Keviczky, T., & De Schutter, B. (2009). Distributed model predictive control of irrigation canals. *Networks and Heterogeneous Media*, 4(2, SI), 359–380. <http://dx.doi.org/10.3934/nhm.2009.4.359>.
- Obando, G., Quijano, N., & Ocampo-Martinez, C. (2022). Decentralized control for urban drainage systems using replicator dynamics. *IEEE Access*, 10, 56740–56762. <http://dx.doi.org/10.1109/ACCESS.2022.3177631>.
- Ocampo-Martinez, C., Barcelli, D., Puig, V., & Bemporad, A. (2012). Hierarchical and decentralised model predictive control of drinking water networks: Application to Barcelona case study. *IET Control Theory & Applications*, 6(1), 62–71. <http://dx.doi.org/10.1049/iet-cta.2010.0737>.
- Ocampo-Martinez, C., Bovo, S., & Puig, V. (2011). Partitioning approach oriented to the decentralised predictive control of large-scale systems. *Journal of Process Control*, 21(5), 775–786.
- Pascual, J., Romera, J., Puig, V., Cembrano, G., Creus, R., & Minoves, M. (2013). Operational predictive optimal control of Barcelona water transport network. *Control Engineering Practice*, 21(8), 1020–1034.
- Payet-Burin, R., Kromman, M., Pereira-Cardenal, S. J., Strzepek, K. M., & Bauer-Gottwein, P. (2021). The Impact of Assuming Perfect Foresight When Planning Infrastructure in the Water-Energy-Food Nexus. *Frontiers in Water*, 3, <http://dx.doi.org/10.3389/frwa.2021.778003>.
- Pedrosa, J., Puig, V., & Nejari, F. (2022). Health-aware economic MPC for operational management of flow-based networks using bayesian networks. *Water*, 14(10), 1538.
- Pereira, M., de la Peña, D. M., Limon, D., Alvarado, I., & Alamo, T. (2016). Application to a drinking water network of robust periodic MPC. *Control Engineering Practice*, 57, 50–60.
- Pianosi, F., & Soncini-Sessa, R. (2009). Real-time management of a multipurpose water reservoir with a hysteresis inflow model. *Water Resources Research*, 45, <http://dx.doi.org/10.1029/2008WR007335>.
- Pirard, T., Kitsikoudis, V., Erpicum, S., Pirotton, M., Archambeau, P., & Dewals, B. (2022). Discharge redistribution as a key process for heuristic optimization of energy production with pumps as turbines in a water distribution network. *Water Resources Management*, 36(4), 1237–1250.
- Poff, N. L., Brown, C. M., Grantham, T. E., Matthews, J. H., Palmer, M. A., Spence, C. M., et al. (2016). Sustainable water management under future uncertainty with eco-engineering decision scaling. *Nature Climate Change*, 6(1), 25–34. <http://dx.doi.org/10.1038/nclimate2765>.
- Pour, F., Puig, V., & Cembrano, G. (2019). Economic health-aware lqv-mpc based on system reliability assessment for water transport network. *Energies*, 12(15), 3015.
- Pour, F. K., Puig, V., & Cembrano, G. (2020). Economic reliability-aware MPC-LPV for operational management of flow-based water networks including chance-constraints programming. *Processes*, 8(1), 60.
- Pour, F. K., Segovia, P., Duviella, E., & Puig, V. (2022). A two-layer control architecture for operational management and hydroelectricity production maximization in inland waterways using model predictive control. *Control Engineering Practice*, 124, <http://dx.doi.org/10.1016/j.conengprac.2022.105172>.
- Puig, V., Cembrano, G., Romera, J., Quevedo, J., Aznar, B., Ramón, G., et al. (2009). Predictive optimal control of sewer networks using CORAL tool: application to Riera Blanca catchment in Barcelona. *Water Science and Technology*, 60(4), 869–878.

- Qin, S. J., & Badgwell, T. A. (2000). An Overview of Nonlinear Model Predictive Control Applications. In F. Allgöwer, & A. Zheng (Eds.), *Nonlinear model predictive control* (pp. 369–392). Basel: Birkhäuser Basel.
- Quijano, N., Ocampo-Martinez, C., Barreiro-Gomez, J., Obando, G., Pantoja, A., & Mojica-Nava, E. (2017). The role of population games and evolutionary dynamics in distributed control systems. *IEEE Control Systems Magazine*, 37(1), 70–97. <http://dx.doi.org/10.1109/MCS.2016.2621479>.
- Rao, Z., & Salomons, E. (2007). Development of a real-time, near-optimal control process for water-distribution networks. *Journal of Hydroinformatics*, 9(1), 25–37.
- Raso, L., & Malaterre, P. O. (2017). Combining Short-Term and Long-Term Reservoir Operation Using Infinite Horizon Model Predictive Control. *Journal of Irrigation and Drainage Engineering*, 143(3), [http://dx.doi.org/10.1061/\(ASCE\)IR.1943-4774.0001063](http://dx.doi.org/10.1061/(ASCE)IR.1943-4774.0001063).
- Raso, L., Schwanenberg, D., van de Giesen, N. C., & van Overloop, P. J. (2014). Short-term optimal operation of water systems using ensemble forecasts. *Advances in Water Resources*, 71, 200–208. <http://dx.doi.org/10.1016/j.advwatres.2014.06.009>.
- Reed, P., Hadka, D., Herman, J., Kasprzyk, J., & Kollat, J. (2013). Evolutionary multi-objective optimization in water resources: The past, present, and future. *35th Year Anniversary Issue*, 51, 438–456. <http://dx.doi.org/10.1016/j.advwatres.2012.01.005>, URL <https://www.sciencedirect.com/science/article/pii/S0309170812000073>.
- Ren, T., Niu, J., Shu, L., Hancke, G. P., Wu, J., Liu, X., et al. (2021). Enabling efficient model-free control of large-scale canals by exploiting domain knowledge. *IEEE Transactions on Industrial Electronics*, 68(9), 8730–8742. <http://dx.doi.org/10.1109/TIE.2020.3013778>.
- Reuss, M. (2003). Is It Time to Resurrect the Harvard Water Program? *Journal of Water Resources Planning and Management*, 129(5), 357–360. [http://dx.doi.org/10.1061/\(ASCE\)0733-9496\(2003\)129:5\(357\)](http://dx.doi.org/10.1061/(ASCE)0733-9496(2003)129:5(357)), URL <https://ascelibrary.org/doi/abs/10.1061/%28ASCE%290733-9496%282003%29129%3A5%28357%29>, eprint: <https://ascelibrary.org/doi/pdf/10.1061/%28ASCE%290733-9496%282003%29129%3A5%28357%29>.
- Riño-Briceño, G., Barreiro-Gomez, J., Ramirez-Jaime, A., Quijano, N., & Ocampo-Martinez, C. (2016). MatSWMM - An open-source software tool for designing real-time control strategies in urban drainage systems. *Environmental Modelling and Software*, 83, 143–154. <http://dx.doi.org/10.1016/j.envsoft.2016.05.009>.
- Rivas-Pérez, R., Feliu-Batlle, V., Castillo-García, F. J., & Linares-Sáez, A. (2014). Mathematical model for robust control of an irrigation main canal pool. *Environmental Modelling & Software*, 51, 207–220. <http://dx.doi.org/10.1016/j.envsoft.2013.10.002>.
- Rodriguez, L. P., Maestre, J. M., Camacho, E. F., & Sanchez, M. C. (2020). Decentralized ellipsoidal state estimation for linear model predictive control of an irrigation canal. *Journal of Hydroinformatics*, 22(3), 593–605. <http://dx.doi.org/10.2166/hydro.2020.150>.
- Roetz, A., & Theobald, S. (2019). Model-Based Operation of Multi-Purpose River and Reservoir Systems. *Water Resources Management*, 33(15), 4969–4982. <http://dx.doi.org/10.1007/s11269-019-02344-2>.
- Romanowicz, R. J., Kiczko, A., & Napiorkowski, J. J. (2010). Stochastic transfer function model applied to combined reservoir management and flow routing. *Hydrological Sciences Journal—Journal Des Sciences Hydrologiques*, 55(1), 27–40. <http://dx.doi.org/10.1080/02626660903526029>.
- Romera, J., Ocampo-Martinez, C., Puig, V., & Quevedo, J. (2013). Flooding management using hybrid model predictive control: application to the Spanish Ebro River. *Journal of Hydroinformatics*, 15(2), 366–380. <http://dx.doi.org/10.2166/hydro.2012.164>.
- Rossman, L. A., et al. (2000). *EPANET 2: Users manual*. US Environmental Protection Agency. Office of Research and Development.
- Rossman, L. A., et al. (2010). *Storm water management model user's manual, version 5.0*. National Risk Management Research Laboratory, Office of Research and Development, US Environmental Protection Agency.
- Sadowska, A., De Schutter, B., & van Overloop, P. J. (2015). Delivery-oriented hierarchical predictive control of an irrigation canal: Event-driven versus time-driven approaches. *IEEE Transactions on Control Systems Technology*, 23(5), 1701–1716. <http://dx.doi.org/10.1109/TCST.2014.2381600>.
- Sadowska, A., van Overloop, P. J., Burt, C., & De Schutter, B. (2014). Hierarchical operation of water level controllers: Formal analysis and application on a large scale irrigation canal. *Water Resources Management*, 28(14), 4999–5019. <http://dx.doi.org/10.1007/s11269-014-0785-x>.
- Sahu, R. K., & McLaughlin, D. B. (2018). An Ensemble Optimization Framework for Coupled Design of Hydropower Contracts and Real-Time Reservoir Operating Rules. *Water Resources Research*, 54(10), 8401–8419. <http://dx.doi.org/10.1029/2018WR022753>.
- Salomons, E., Goryashko, A., Shamir, U., Rao, Z., & Alvisi, S. (2007). Optimizing the operation of the haifa-a water-distribution network. *Journal of Hydroinformatics*, 9(1), 51–64.
- Salomons, E., & Housh, M. (2020a). A practical optimization scheme for real-time operation of water distribution systems. *Journal of Water Resources Planning and Management*, 146(4), 04020016.
- Salomons, E., & Housh, M. (2020b). Practical real-time optimization for energy efficient water distribution systems operation. *Journal of Cleaner Production*, 275, 124148.
- Salvador, J. R., Muñoz de la Peña, D., Ramirez, D., & Alamo, T. (2020). Predictive control of a water distribution system based on process historian data. *Optimal Control Applications & Methods*, 41(2), 571–586.
- Sankar, G. S., Kumar, S. M., Narasimhan, S., Narasimhan, S., & Bhallamudi, S. M. (2015). Optimal control of water distribution networks with storage facilities. *Journal of Process Control*, 32, 127–137.
- Scattolini, R. (2009). Architectures for distributed and hierarchical Model Predictive Control – A review. *Journal of Process Control*, 19(5), 723–731. <http://dx.doi.org/10.1016/j.jprocont.2009.02.003>, URL <https://www.sciencedirect.com/science/article/pii/S0959152409000353>.
- Schuurmans, J., Bosgra, O. H., & Brouwer, R. (1995). Open-channel flow model approximation for controller design. *Applied Mathematical Modelling*, 19(9), 525–530. [http://dx.doi.org/10.1016/0307-904X\(95\)00053-M](http://dx.doi.org/10.1016/0307-904X(95)00053-M).
- Schuurmans, J., Clemmens, A. J., Dijkstra, S., Hof, A., & Brouwer, R. (1999). Modeling of irrigation and drainage canals for controller design. *Journal of Irrigation and Drainage Engineering*, 125(6), 338–344.
- Schwenzer, M., Ay, M., Bergs, T., & Abel, D. (2021). Review on model predictive control: an engineering perspective. *International Journal of Advanced Manufacturing Technology*, 117(5), 1327–1349. <http://dx.doi.org/10.1007/s00170-021-07682-3>.
- Segovia, P., Rajaoarisoa, L., Nejjari, F., Duviella, E., & Puig, V. (2019). Model predictive control and moving horizon estimation for water level regulation in inland waterways. *Journal of Process Control*, 76, 1–14. <http://dx.doi.org/10.1016/j.jprocont.2018.12.017>.
- Shahdany, S. M. H., Maestre, J. M., & van Overloop, P. J. (2015). Equitable water distribution in main irrigation canals with constrained water supply. *Water Resources Management*, 29(9), 3315–3328. <http://dx.doi.org/10.1007/s11269-015-1000-4>.
- Shahdany, S. M. H., Majd, E. A., Firoozfar, A., & Maestre, J. M. (2016). Improving operation of a main irrigation canal suffering from inflow fluctuation within a centralized model predictive control system: Case study of Roodasht canal, Iran. *Journal of Irrigation and Drainage Engineering*, 142(11), [http://dx.doi.org/10.1061/\(ASCE\)IR.1943-4774.0001087](http://dx.doi.org/10.1061/(ASCE)IR.1943-4774.0001087).
- Shahdany, S. M. H., Taghvaeian, S., Maestre, J. M., & Firoozfar, A. R. (2019). Developing a centralized automatic control system to increase flexibility of water delivery within predictable and unpredictable irrigation water demands. *Computers and Electronics in Agriculture*, 163, <http://dx.doi.org/10.1016/j.compag.2019.104862>.
- Shamir, U., & Salomons, E. (2008). Optimal real-time operation of urban water distribution systems using reduced models. *Journal of Water Resources Planning and Management*, 134(2), 181–185.
- Shang, C., Chen, W.-H., Stroock, A. D., & You, F. (2020). Robust model predictive control of irrigation systems with active uncertainty learning and data analytics. *IEEE Transactions on Control Systems Technology*, 28(4), 1493–1504. <http://dx.doi.org/10.1109/TCST.2019.2916753>.
- Shishegar, S., Duchesne, S., Pelletier, G., & Ghorbani, R. (2021). A smart predictive framework for system-level stormwater management optimization. *Journal of Environmental Management*, 278, Article 111505.
- Soncini-Sessa, R., Castelletti, A., & Weber, E. (2007). *Integrated and participatory water resources management: Theory*. Elsevier.
- Sreeparathy, V., & Srinivas, V. V. (2022). Global assessment of spatiotemporal variability of wet, normal and dry conditions using multiscale entropy-based approach. *Scientific Reports*, 12(1), 9767. <http://dx.doi.org/10.1038/s41598-022-13830-w>.
- Srivastava, S., Mehta, L., & Naess, L. O. (2022). Increased attention to water is key to adaptation. *Nature Climate Change*, 12(2), 113–114. <http://dx.doi.org/10.1038/s41558-022-01277-w>.
- Stefanizzi, M., Capurso, T., Balacco, G., Binetti, M., Camporeale, S. M., & Torresi, M. (2020). Selection, control and techno-economic feasibility of pumps as Turbines in Water Distribution Networks. *Renewable Energy*, 162, 1292–1306.
- Stevenson, S., Coats, S., Touma, D., Cole, J., Lehner, F., Fasullo, J., et al. (2022). Twenty-first century hydroclimate: A continually changing baseline, with more frequent extremes. *Proceedings of the National Academy of Sciences*, 119(12), Article e2108124119. <http://dx.doi.org/10.1073/pnas.2108124119>, URL <https://www.pnas.org/doi/abs/10.1073/pnas.2108124119>, eprint: <https://www.pnas.org/doi/pdf/10.1073/pnas.2108124119>.
- Sun, C. C., Puig, V., & Cembrano, G. (2016). Combining CSP and MPC for the operational control of water networks. *Engineering Applications of Artificial Intelligence*, 49, 126–140.
- Sun, C., Romero, L., Joseph-Duran, B., Meseguer, J., Muñoz, E., Guasch, R., et al. (2020). Integrated pollution-based real-time control of sanitation systems. *Journal of Environmental Management*, 269, Article 110798.
- Svensen, J. L., Sun, C., Cembrano, G., & Puig, V. (2021). Chance-constrained stochastic MPC of Astlingen urban drainage benchmark network. *Control Engineering Practice*, 115, 104900.
- Tedesco, F., Ocampo-Martinez, C., Casavola, A., & Puig, V. (2016). Centralized and distributed command governor approaches for water supply systems management. *IEEE Transactions on Systems, Man, and Cybernetics: Systems*, 48(4), 586–595.
- Tian, X., Aydin, B. E., Negenborn, R. R., van de Giesen, N., & Maestre, J. M. (2017a). Model predictive control for water level control in the case of spills. *Journal of Irrigation and Drainage Engineering*, 143(3, SI), [http://dx.doi.org/10.1061/\(ASCE\)IR.1943-4774.0001133](http://dx.doi.org/10.1061/(ASCE)IR.1943-4774.0001133).
- Tian, X., Guo, Y., Negenborn, R. R., Wei, L., Lin, N. M., & Maestre, J. M. (2019). Multi-scenario model predictive control based on genetic algorithms for level regulation of open water systems under ensemble forecasts. *Water Resources Management*, 33(9), 3025–3040. <http://dx.doi.org/10.1007/s11269-019-02284-x>.



- Tian, X., Negenborn, R. R., van Overloop, P. J., Maestre, J. M., Sadowska, A., & van de Giesen, N. (2017b). Efficient multi-scenario Model Predictive Control for water resources management with ensemble streamflow forecasts. *Advances in Water Resources*, 109, 58–68. <http://dx.doi.org/10.1016/j.advwatres.2017.08.015>.
- Tian, X., van Overloop, P. J., Negenborn, R. R., & van de Giesen, N. (2015). Operational flood control of a low-lying delta system using large time step Model Predictive Control. *Advances in Water Resources*, 75, 1–13. <http://dx.doi.org/10.1016/j.advwatres.2014.10.010>.
- Trapiello, C., Puig, V., & Cembrano, G. (2021). Reconfiguration of large-scale systems using back-up components. *Computers & Chemical Engineering*, 149, Article 107288.
- Trenberth, K. E., Dai, A., van der Schrier, G., Jones, P. D., Barichivich, J., Briffa, K. R., et al. (2014). Global warming and changes in drought. *Nature Climate Change*, 4(1), 17–22. <http://dx.doi.org/10.1038/nclimate2067>.
- Uysal, G., Alvarado-Montero, R., Schwanenberg, D., & Sensoy, A. (2018a). Real-Time Flood Control by Tree-Based Model Predictive Control Including Forecast Uncertainty: A Case Study Reservoir in Turkey. *Water*, 10(3), <http://dx.doi.org/10.3390/w10030340>.
- Uysal, G., Schwanenberg, D., Alvarado-Montero, R., & Sensoy, A. (2018b). Short Term Optimal Operation of Water Supply Reservoir under Flood Control Stress using Model Predictive Control. *Water Resources Management*, 32(2), 583–597. <http://dx.doi.org/10.1007/s11269-017-1828-x>.
- van der Heijden, T., Lugt, D., van Nooijen, R., Palensky, P., & Abraham, E. (2022). Multi-market demand response from pump-controlled open canal systems: an economic MPC approach to pump-scheduling. *Journal of Hydroinformatics*, 24(4), 838–855. <http://dx.doi.org/10.2166/hydro.2022.018>.
- Van Der Werf, J. A., Kapelan, Z., & Langeveld, J. (2022). Towards the long term implementation of real time control of combined sewer systems: a review of performance and influencing factors. *Water Science and Technology*, 85(4), 1295–1320.
- van Ekeren, H., Negenborn, R. R., van Overloop, P. J., & De Schutter, B. (2013). Time-instant optimization for hybrid model predictive control of the Rhine-Meuse delta. *Journal of Hydroinformatics*, 15(2), 271–292. <http://dx.doi.org/10.2166/hydro.2013.177>.
- van Overloop, P. J., Clemmens, A. J., Strand, R. J., Wagemaker, R. M. J., & Bautista, E. (2010). Real-time implementation of model predictive control on Maricopa-Stanfield irrigation and drainage district's WM canal. *Journal of Irrigation and Drainage Engineering*, 136(11), 747–756. [http://dx.doi.org/10.1061/\(ASCE\)IR.1943-4774.0000256](http://dx.doi.org/10.1061/(ASCE)IR.1943-4774.0000256).
- van Overloop, P. J., Horvath, K., & Aydin, B. E. (2014). Model predictive control based on an integrator resonance model applied to an open water channel. *Control Engineering Practice*, 27, 54–60. <http://dx.doi.org/10.1016/j.conengprac.2014.03.001>.
- van Overloop, P. J., Maestre, J. M., Sadowska, A. D., Camacho, E. F., & De Schutter, B. (2015). Human-in-the-loop model predictive control of an irrigation canal. *IEEE Control Systems Magazine*, 35(4), 19–29. <http://dx.doi.org/10.1109/MCS.2015.2427040>.
- van Overloop, P. J., Miltenburg, I. J., Bombois, X., Clemmens, A. J., Strand, R., & van de Giesen, N. (2010). Identification of resonance waves in open water channels. *Control Engineering Practice*, 18(8), 863–872.
- van Overloop, P. J., Weijs, S., & Dijkstra, S. (2008). Multiple model predictive control on a drainage canal system. *Control Engineering Practice*, 16(5), 531–540. <http://dx.doi.org/10.1016/j.conengprac.2007.06.002>.
- van Ruijven, B. J., De Cian, E., & Sue Wing, I. (2019). Amplification of future energy demand growth due to climate change. *Nature Communications*, 10(1), 2762. <http://dx.doi.org/10.1038/s41467-019-10399-3>.
- Velarde, P., Tian, X., Sadowska, A. D., & Maestre, J. M. (2019). Scenario-based hierarchical and distributed MPC for water resources management with dynamical uncertainty. *Water Resources Management*, 33(2), 677–696. <http://dx.doi.org/10.1007/s11269-018-2130-2>.
- Venturini, M., Alvisi, S., Simani, S., & Manservigi, L. (2017). Energy production by means of pumps as turbines in water distribution networks. *Energies*, 10(10), 1666.
- Wagenpfeil, J., Arnold, E., Linke, H., & Sawodny, O. (2012). Modelling and optimized water management of artificial inland waterway systems. *Journal of Hydroinformatics*, 15(2), 348–365. <http://dx.doi.org/10.2166/hydro.2012.163>.
- Wahlin, B. (2004). Performance of model predictive control on ASCE test canal 1. *Journal of Irrigation and Drainage Engineering*, 130(3), 227–238. [http://dx.doi.org/10.1061/\(ASCE\)0733-9437\(2004\)130:3\(227\)](http://dx.doi.org/10.1061/(ASCE)0733-9437(2004)130:3(227)).
- Wahlin, B. T., & Clemmens, A. J. (2006a). Automatic downstream water-level feedback control of branching canal networks: Simulation results. *Journal of Irrigation and Drainage Engineering*, 132(3), 208–219. [http://dx.doi.org/10.1061/\(ASCE\)0733-9437\(2006\)132:3\(208\)](http://dx.doi.org/10.1061/(ASCE)0733-9437(2006)132:3(208)).
- Wahlin, B. T., & Clemmens, A. J. (2006b). Automatic downstream water-level feedback control of branching canal networks: Theory. *Journal of Irrigation and Drainage Engineering*, 132(3), 198–207. [http://dx.doi.org/10.1061/\(ASCE\)0733-9437\(2006\)132:3\(198\)](http://dx.doi.org/10.1061/(ASCE)0733-9437(2006)132:3(198)).
- Walski, T. M., Chase, D. V., Savic, D. A., Grayman, W., Beckwith, S., & Koelle, E. (2003). Advanced water distribution modeling and management.
- Wan, W., Zhao, J., Lund, J. R., Zhao, T., Lei, X., & Wang, H. (2016). Optimal Hedging Rule for Reservoir Refill. *Journal of Water Resources Planning and Management*, 142(11), [http://dx.doi.org/10.1061/\(ASCE\)WR.1943-5452.0000692](http://dx.doi.org/10.1061/(ASCE)WR.1943-5452.0000692).
- Wang, J. (2010). A new stochastic control approach to multireservoir operation problems with uncertain forecasts. *Water Resources Research*, 46, <http://dx.doi.org/10.1029/2008WR007217>.
- Wang, W.-C., Chau, K.-W., Cheng, C.-T., & Qiu, L. (2009). A comparison of performance of several artificial intelligence methods for forecasting monthly discharge time series. *Journal of Hydrology*, 374(3), 294–306. <http://dx.doi.org/10.1016/j.jhydrol.2009.06.019>, URL <https://www.sciencedirect.com/science/article/pii/S0022169409003527>.
- Wang, L., Koike, T., Ikeda, M., Tinh, D. N., Nyunt, C. T., Saavedra, O., et al. (2014). Optimizing Multidam Releases in Large River Basins by Combining Distributed Hydrological Inflow Predictions with Rolling-Horizon Decision Making. *Journal of Water Resources Planning and Management*, 140(10), [http://dx.doi.org/10.1061/\(ASCE\)WR.1943-5452.0000452](http://dx.doi.org/10.1061/(ASCE)WR.1943-5452.0000452).
- Wang, Y., Ocampo-Martinez, C., & Puig, V. (2016). Stochastic model predictive control based on Gaussian processes applied to drinking water networks. *IET Journal on Control Theory and Applications*, 10(8), 947–955. <http://dx.doi.org/10.1049/iet-cta.2015.0657>.
- Wang, Y., Puig, V., & Cembrano, G. (2017). Non-linear economic model predictive control of water distribution networks. *Journal of Process Control*, 56, 23–34.
- Wang, Y., Salvador, J. R., de la Pena, D. M., Puig, V., & Cembrano, G. (2018). Economic model predictive control based on a periodicity constraint. *Journal of Process Control*, 68, 226–239.
- Wang, S., Taha, A. F., Gatsis, N., & Giacomoni, M. H. (2020). Receding horizon control for drinking water networks: The case for geometric programming. *IEEE Transactions on Control of Network Systems*, 7(3), 1151–1163.
- Wang, X., Tian, W., & Liao, Z. (2021a). Offline optimization of sluice control rules in the urban water system for flooding mitigation. *Water Resources Management*, 35, 949–962.
- Wang, Y., Too Yok, K., Wu, W., Simpson, A. R., Weyer, E., & Manzie, C. (2021b). Minimizing pumping energy cost in real-time operations of water distribution systems using economic model predictive control. *Journal of Water Resources Planning and Management*, 147(7), Article 04021042.
- Wei, X., & Xun, Y. (2019). Evaluation of the effective forecast and decision horizon in optimal hydropower generation considering medium-range precipitation forecasts. *Water Supply*, 19(7), 2147–2155. <http://dx.doi.org/10.2166/ws.2019.095>.
- van der Werf, J. A., Kapelan, Z., & Langeveld, J. (2021). Quantifying the true potential of real time control in urban drainage systems. *Urban Water Journal*, 18(10), 873–884.
- Wetterhall, F., & Di Giuseppe, F. (2018). The benefit of seamless forecasts for hydrological predictions over Europe. *Hydrology and Earth System Sciences*, 22(6), 3409–3420. <http://dx.doi.org/10.5194/hess-22-3409-2018>, URL <https://hess.copernicus.org/articles/22/3409/2018/>.
- Weyer, E. (2001). System identification of an open water channel. *Control Engineering Practice*, 9(12), 1289–1299.
- Wild, T., Reed, P., Loucks, D., Mallen-Cooper, M., & Jensen, E. (2019). Balancing Hydropower Development and Ecological Impacts in the Mekong: Tradeoffs for Sambor Mega Dam. *Journal of Water Resources Planning and Management*, 145(2), Article 05018019.
- Wu, W., Dandy, G. C., & Maier, H. R. (2014). Protocol for developing ANN models and its application to the assessment of the quality of the ANN model development process in drinking water quality modelling. *Environmental Modelling & Software*, 54, 108–127. <http://dx.doi.org/10.1016/j.envsoft.2013.12.016>, URL <https://www.sciencedirect.com/science/article/pii/S1364815213003198>.
- Wu, W., Emerton, R., Duan, Q., Wood, A. W., Wetterhall, F., & Robertson, D. E. (2020). Ensemble flood forecasting: Current status and future opportunities. *WIREs Water*, 7(3), Article e1432. <http://dx.doi.org/10.1002/wat2.1432>, Publisher: John Wiley & Sons, Ltd.
- Wu, W., Maier, H. R., Dandy, G. C., Arora, M., & Castelletti, A. (2020). The changing nature of the water–energy nexus in urban water supply systems: A critical review of changes and responses. *Journal of Water and Climate Change*, 11(4), 1095–1122. <http://dx.doi.org/10.2166/wcc.2020.276>.
- Xu, M. (2017). Model predictive control of an irrigation canal using dynamic target trajectory. *Journal of Irrigation and Drainage Engineering*, 143(3, SI), [http://dx.doi.org/10.1061/\(ASCE\)IR.1943-4774.0001084](http://dx.doi.org/10.1061/(ASCE)IR.1943-4774.0001084).
- Xu, M., Negenborn, R. R., van Overloop, P. J., & van de Giesen, N. C. (2012). De Saint-Venant equations-based model assessment in model predictive control of open channel flow. *Advances in Water Resources*, 49, 37–45. <http://dx.doi.org/10.1016/j.advwatres.2012.07.004>.
- Xu, M., van Overloop, P. J., & van de Giesen, N. C. (2011). On the study of control effectiveness and computational efficiency of reduced Saint-Venant model in model predictive control of open channel flow. *Advances in Water Resources*, 34(2), 282–290. <http://dx.doi.org/10.1016/j.advwatres.2010.11.009>.
- Xu, M., van Overloop, P. J., & van de Giesen, N. C. (2013). Model reduction in model predictive control of combined water quantity and quality in open channels. *Environmental Modelling & Software*, 42, 72–87. <http://dx.doi.org/10.1016/j.envsoft.2012.12.008>.
- Xu, M., & Schwanenberg, D. (2017). Sequential and simultaneous model predictive control of a drainage canal network using an implicit diffusive wave model. *Journal of Irrigation and Drainage Engineering*, 143(3, SI), [http://dx.doi.org/10.1061/\(ASCE\)IR.1943-4774.0001082](http://dx.doi.org/10.1061/(ASCE)IR.1943-4774.0001082).

- Xu, W., Zhao, J., Zhao, T., & Wang, Z. (2015). Adaptive Reservoir Operation Model Incorporating Nonstationary Inflow Prediction. *Journal of Water Resources Planning and Management*, 141(8), Article 04014099. [http://dx.doi.org/10.1061/\(ASCE\)WR.1943-5452.0000502](http://dx.doi.org/10.1061/(ASCE)WR.1943-5452.0000502), URL <https://ascelibrary.org/doi/abs/10.1061/%28ASCE%29WR.1943-5452.0000502>, eprint: <https://ascelibrary.org/doi/pdf/10.1061/%28ASCE%29WR.1943-5452.0000502>.
- Xu, B., Zhong, P.-a., Lu, Q., Zhu, F., Huang, X., Ma, Y., et al. (2020). Multiobjective stochastic programming with recourses for real-time flood water conservation of a multireservoir system under uncertain forecasts. *Journal of Hydrology*, 590, <http://dx.doi.org/10.1016/j.jhydrol.2020.125513>.
- Yeh, W. W.-G. (1985). Reservoir Management and Operations Models: A State-of-the-Art Review. *Water Resources Research*, 21(12), 1797–1818. <http://dx.doi.org/10.1029/WR021i012p01797>, URL <https://agupubs.onlinelibrary.wiley.com/doi/abs/10.1029/WR021i012p01797>, eprint: <https://agupubs.onlinelibrary.wiley.com/doi/pdf/10.1029/WR021i012p01797>.
- Yuan, Z., Olsson, G., Cardell-Oliver, R., van Schagen, K., Marchi, A., Deletic, A., et al. (2019). Sweating the assets—the role of instrumentation, control and automation in urban water systems. *Water Research*, 155, 381–402.
- Zafra-Cabeza, A., Maestre, J. M., Ridao, M. A., Camacho, E. F., & Sanchez, L. (2011). A hierarchical distributed model predictive control approach to irrigation canals: A risk mitigation perspective. *Journal of Process Control*, 21(5, SI), 787–799. <http://dx.doi.org/10.1016/j.jprocont.2010.12.012>.
- Zambelli, M., Soares Filho, S., Toscano, A. E., Santos, E. d., & Silva Filho, D. d. (2011). Newave versus Odin: Comparison of Stochastic and Deterministic Models for the Long Term Hydropower Scheduling of the Interconnected Brazilian System. *Sba: Controle & Automação Sociedade Brasileira de Automatica*, 22(6), 598–609. <http://dx.doi.org/10.1590/S0103-17592011000600005>.
- Zhao, M., & Boll, J. (2022). Adaptation of Water Resources Management under climate change. *Frontiers in Water*, 4, URL <https://www.frontiersin.org/articles/10.3389/frwa.2022.983228>.
- Zhao, P., Wang, Q. J., Wu, W., & Yang, Q. (2021). Which precipitation forecasts to use? Deterministic versus coarser-resolution ensemble NWP models. *Quarterly Journal of the Royal Meteorological Society*, 147(735), 900–913. <http://dx.doi.org/10.1002/qj.3952>, Publisher: John Wiley & Sons, Ltd.
- Zheng, Z., Wang, Z., Zhao, J., & Zheng, H. (2019). Constrained model predictive control algorithm for cascaded irrigation canals. *Journal of Irrigation and Drainage Engineering*, 145(6), [http://dx.doi.org/10.1061/\(ASCE\)IR.1943-4774.0001390](http://dx.doi.org/10.1061/(ASCE)IR.1943-4774.0001390).
- Zhu, Z., Guan, G., Mao, Z., Wang, K., Gu, S., & Chen, G. (2020). Application of model predictive control for large-scale inverted siphon in water distribution system in the case of emergency operation. *Water*, 12(10), <http://dx.doi.org/10.3390/w12102733>.
- Zmijewski, N., Bottacin-Busolin, A., & Worman, A. (2016). Incorporating Hydrologic Routing into Reservoir Operation Models: Implications for Hydropower Production Planning. *Water Resources Management*, 30(2), 623–640. <http://dx.doi.org/10.1007/s11269-015-1181-x>.