

**Personæ**

**Users' evaluation of a music technology education project**

Delle Monache, Stefano; Mandanici, Marcella; Alessandretti, Stefano; Di Filippo, Roberto

**DOI**

[10.1386/jmte\\_00042\\_1](https://doi.org/10.1386/jmte_00042_1)

**Publication date**

2023

**Document Version**

Final published version

**Published in**

Journal of Music, Technology & Education

**Citation (APA)**

Delle Monache, S., Mandanici, M., Alessandretti, S., & Di Filippo, R. (2023). Personæ: Users' evaluation of a music technology education project. *Journal of Music, Technology & Education*, 14(2-3), 231-248. [https://doi.org/10.1386/jmte\\_00042\\_1](https://doi.org/10.1386/jmte_00042_1)

**Important note**

To cite this publication, please use the final published version (if applicable). Please check the document version above.

**Copyright**

Other than for strictly personal use, it is not permitted to download, forward or distribute the text or part of it, without the consent of the author(s) and/or copyright holder(s), unless the work is under an open content license such as Creative Commons.

**Takedown policy**

Please contact us and provide details if you believe this document breaches copyrights. We will remove access to the work immediately and investigate your claim.

***Green Open Access added to TU Delft Institutional Repository***

***'You share, we take care!' - Taverne project***

**<https://www.openaccess.nl/en/you-share-we-take-care>**

Otherwise as indicated in the copyright section: the publisher is the copyright holder of this work and the author uses the Dutch legislation to make this work public.

Journal of Music, Technology & Education  
Volume 14 Numbers 2 & 3

© 2022 (2021) Intellect Ltd Article. English language. [https://doi.org/10.1386/jmte\\_00042\\_1](https://doi.org/10.1386/jmte_00042_1)

Received 18 March 2021; Accepted 21 October 2021

---

**STEFANO DELLE MONACHE**

Delft University of Technology

**MARCELLA MANDANICI**

Music Conservatory of Brescia

**STEFANO ALESSANDRETTI**

Music Conservatory of Brescia

**ROBERTO DI FILIPPO**

Liceo Musicale Veronica Gambarà

# Personæ: Users' evaluation of a music technology education project

## ABSTRACT

*'Personæ' is an interactive large-scale space sound installation designed by the students of the music technology classes of the 'V. Gambarà' music high school in Brescia (Italy). The activities that led to the conception and realization of the installation were part of 'The Discovery of Interactive Spaces' project, a set of extracurricular workshops organized by the authors of this article between spring 2019 and winter 2020 with the support of the Italian National Operation Program (PON). At the end of January 2020, the installation was presented during a public event and an evaluation questionnaire was administered to 79 visitors. The purpose of this research is to assess how the public, students, parents, teachers and classmates received the 'Personæ' installation, and the technology integration within regular study curricula. While the majority of visitors have well received the artistic and communicative value of the installation, the questionnaire reveals*

## KEYWORDS

technology integration  
sound installation  
large-scale responsive  
environments  
interactive spaces  
bodily interaction  
users survey

Delivered by Intellect to:

Marcella Mandanici (33327976)

IP: 5.90.73.43

On: Sat, 18 Feb 2023 07:59:29

*that there is not a similar uniformity of agreement on some aspects of technology integration in school curricula.*

## 1. INTRODUCTION

In the context of this manuscript with the expression ‘interactive spaces’ we mean surfaces or portions of volumes placed within the range of sensors capable of tracking the presence and/or movement of one or more people. Consider for instance the case of a camera hanging from the ceiling and facing parallel to the floor. Depending on the height of the ceiling, the field of view of the camera corresponds to a rectangle of approximately  $3 \times 4$  m, an area large enough for a user to walk through. Computer vision algorithms can process the data coming from the camera, allowing the extraction of various features, such as the presence of one or more users, the speed and direction of their movements.

Another kind of interactive space is the portion of volume produced by the Leap Motion sensor, an infrared light device which is able to track the movements of the hands inside a 3D space corresponding to an inverted pyramid of about 60 cm in height and with the tip placed on the sensor (Leap Motion 2021). These spaces, produced by various motion tracking devices and technologies, can be employed for interactive graphics, virtual reality games, augmented reality applications, media and entertainment (Welch and Foxlin 2002). More recently, off-the-shelf motion tracking devices, such as Kinect (Wikipedia 2021) and Leap Motion, became very popular, thanks to the growth of communities of developers and online forums (Azure Kinect 2021).

When a user enters an interactive space, she can produce an audio and visual output depending on her gestures. The bodily interaction is simple and intuitive, as the sensorimotor action–perception loop shapes learning and facilitates information processing (Gordon et al. 2011). The consequent emotional and cognitive responses are the basis of a number of applications designed for entertainment, communication, games, learning and caring for various disabilities (Mandanici et al. 2018). Furthermore, depending on their size, interactive spaces allow a shared and participatory use, which increases their value in terms of social involvement (De Kort and Ijsselsteijn 2008).

As an example, Figure 1 depicts a large-scale responsive environment with floor projections of a single user game. The remainder of the students are standing along the edges of the playground, looking at the player and suggesting the best next move.

The technologies listed above have a great potential in terms of communication, ease of implementation and expressivity. These characteristics constitute the ideal terrain for teaching technologies and fostering technological integration. For this reason, they were chosen as the focus of ‘The Discovery of Interactive Spaces’ project, a set of workshops for high school music technology classes. The project was achieved through the following actions:

1. introducing the students to the available technologies for motion tracking,
2. providing exemplar cases of sonic and graphic production through bodily interaction,
3. stimulating their creativity by designing and realizing an application.

Delivered by Intellect to:

Marcella Mandanici (33327976)

IP: 5.90.73.43

On: Sat, 18 Feb 2023 07:59:29

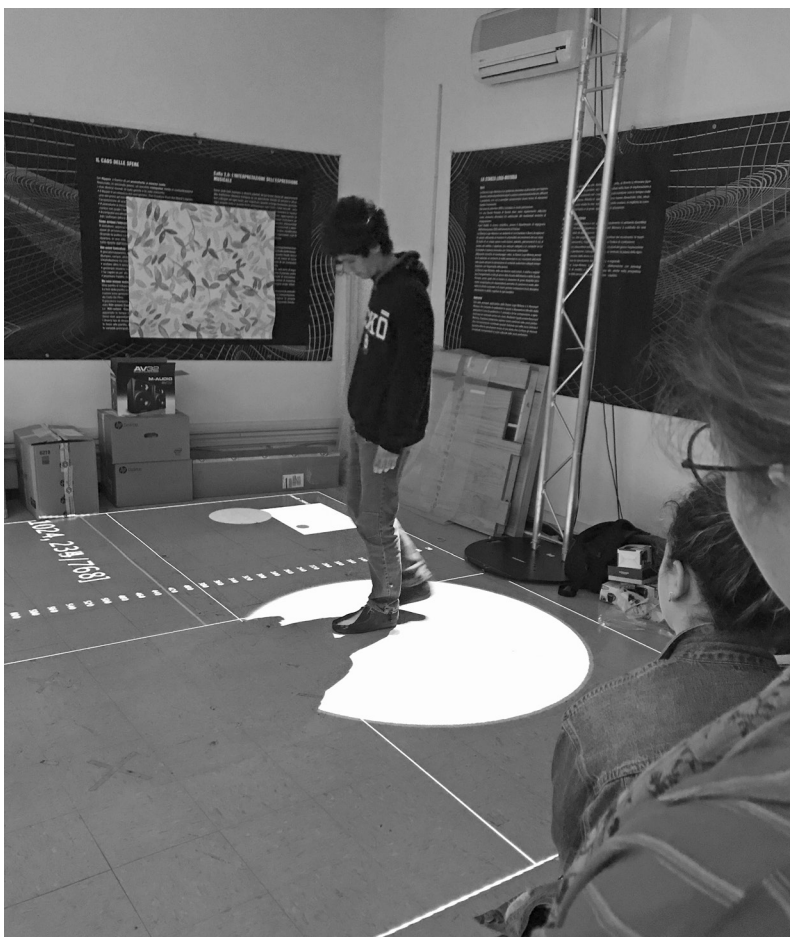

*Figure 1: An example of large-scale responsive environment with floor projections experimented by the participants during a visit to the laboratory of the Sound and Music Computing Group, University of Padua (Italy).*

These activities were aimed at making the students more aware of the links between technological means and social utility. By realizing a concrete collective prototyping activity, the students could experience participatory and creative aspects of technological development. In addition, the project focused on fostering computational thinking, that is, the ability of formulating a problem in a way that a computer can use to solve it. According to Wing (2006) computational thinking is a fundamental ability for the twenty-first-century students and its teaching is crucial as teaching writing and arithmetic.

### **1.1 Project objectives and students' curriculum integration**

According to Educare Digitale, a report from the Italian telecommunications authority AGCOM (Agcom 2019), the Italian schools have yet to complete much of the digitization process that can help the country to improve its 25th place out of 28 European countries for digital performance (DESI 2019).

The gap is not only due to the lack of infrastructure (fast internet connections, computers and other electronic devices), but also to the backwardness of educational approaches and the lack of training of the teaching staff, as evidenced by the fact that only 47 per cent of Italian teachers employ digital devices during their teaching activities. Thus, before the project kick-off, we administered a questionnaire to the participants to analyse their level of digital literacy. The results showed that students use digital tools in a rather limited way, and more at home than during school time. Since they are music technology students, we also investigated the use of music software, such as Digital Audio Workstation (DAW), music editors and music notation software. No programming software such as MAX (Cycling '74 2021) and Pure Data (Puredata 2021) were mentioned by participants (Mandanici et al. 2021).

Open discussions with the students on the pros and cons of digital technologies in the school environment stressed the possibility of accessing a large amount of information, the greater involvement of students in teaching activities, the opportunity to tailor teaching and learning, and more in general the opportunity to prepare the students to live in a world more and more based on technology. On the other hand, very little concern has been expressed by the students about other well-known negative issues related to the use of technologies in schools. It seems that the possible loss of human relationships, distraction and misuse of communication technologies, such as social media blogs and chats, are not at the centre of students' concerns. Rather, many students raised the issue of unsatisfactory teaching in terms of poor interactivity between teachers and students. It is significant that such a strong and precise critique of teachers' teaching has emerged in the context of a discussion on technologies. Thus, if it is certainly true that technology is not the definitive solution for the improvement of teaching (Himonides 2019), from our experience it emerges that students somehow expect a turning point from the use of technologies and that they link the lack of technological integration in schools to an educational style that is inadequate to current times.

With these premises in mind, we addressed the students' activities to offer a creative experience, enhance technological competences, reinforce computational thinking and advance knowledge of music production technologies. A further goal of the project was to promote reflection on the level of technological training offered in the school programmes, in the light of the creative experience realised during the project. Particularly we investigated to what extent students and parents would accept possible changes in the school curriculum, based on their experience of the 'Personæ' installation. In this respect, during the public presentation of the installation, we administered a questionnaire to the visitors.

In the remainder of this article we describe the project activities with particular attention to the explanation of motion tracking technologies and devices. Beyond that, during 'The Discovery of Interactive Spaces' project, elementary programming and digital sound processing techniques were also addressed (Section 2). At the end of these activities the students began a brainstorming process aiming at proposing the design of an original artwork, the interactive installation 'Personæ'. The creation and implementation process of 'Personæ' is thoroughly described in Section 3, while the evaluation questionnaire and its results are presented and discussed in Section 4. Conclusions are drawn in Section 5.

Delivered by Intellect to:

Marcella Mandanici (33327976)

IP: 5.90.73.43

On: Sat, 18 Feb 2023 07:59:29

## 2. THE LEARNING PROCESS IN ‘THE DISCOVERY OF INTERACTIVE SPACES’ PROJECT

1. See <http://csc.dei.unipd.it/>. Accessed 10 February 2021.

The project took place at the music high school ‘V. Gambara’ (Brescia, Italy) between April 2018 and January 2019, with the partnership of the CSC-Sound and Music Computing Group, Department of Information Engineering of the University of Padua (Italy).<sup>1</sup> Twenty-eight students (fourteen females, age  $M = 16.21$ ,  $ST = 1.13$ ) joined the programme on a voluntary basis. ‘The Discovery of Interactive Spaces’ included 90 h of extracurricular workshops, to be held once a week in the afternoon at the music technology laboratory of the school. The project was supported by the National Operation Program (PON) within the framework of ‘Fondo Sociale Europeo (FSE)’, with the aim of ‘developing logical and computational thinking and digital creativity’ (MIUR 2017: 10). For this reason, the project activities focused on providing students with the knowledge and skills to enable autonomous design and prototyping. This pedagogical approach was inspired by learning by design, a form of project-based learning where students acquire skills through a concrete creative experience (Mergendoller et al. 2006).

The project activities were arranged into two subsequent stages lasting 60 and 30 h respectively. In the first stage we took turns in laboratory activities and we introduced the students to the possibilities of motion tracking devices and systems in three different areas of use:

1. social utility and communication,
2. inclusion of disabled people,
3. artistic expression.

For the first area we presented some educational games available on the market such as Wizefloor (Osbornetechnologies 2021) and SMALLab Learning (2021). These are two large scale interactive environments where learning is stimulated through physical involvement. Another similar environment is La Stanza Logomotoria (Zanolla et al. 2010) that has been used for children suffering from dyslexia (second area). Finally, artistic production has been represented by the potentialities expressed by the OpenPTrack system (Openprack 2015), which provides a multi-camera person tracking particularly fit for large spaces.

The characteristics of the technologies employed in these examples were discussed from both the communicative and the technical viewpoints. Particularly, motion data coming from an RGB camera were compared to the depth images produced by the Kinect V1 and V2 sensors (Wasenmüller and Stricker 2017), and some of the main computer vision techniques such as colour tracking, motion and blob detection were presented (Parker 2010).

In addition to the theoretical explanation, students approached some basic concepts of human–computer interaction by analysing installation examples developed at the CSC (see Figure 1). For each installation the students analysed the tracking system and its application in a context of real use, with a focus on the relationships between the user’s movements and the visual and/or audio output produced. Moreover, during the workshops a broad space was devoted to explore the possibilities offered by the interaction of motion tracking technologies and digital sound processing supported by software such as MAX and Pure Data. Simple sound design experiences, environmental sound

recordings and foley activities completed the curriculum of the first stage of the project.

In the second stage the management of the project passed completely into the hands of the students. Here the teachers took on the role of facilitators with the aim of supporting the students in the realisation of their design into the final prototype. This process began with a brainstorming activity where the students proposed a series of original projects based on the possibilities examined during the workshops. The projects are summarised in Table 1.

They are organized into music, multimedia, game, education and communication projects. While it is evident that the students' ideas were biased both by the proposed examples and by their musical background, it should be noted that no proposal concerns explicitly the inclusion of people with disabilities. Probably the theme was too complex, it was not presented in the right way during the workshops or simply other aspects of the project most attracted the attention of students. Despite the teachers' effort to connect design ideas with the effective possibilities of the available technologies, the students were very impressed by the potential of these systems, without often fully realising the technological means necessary to implement them.

After a careful analysis of the proposed projects, the students agreed that the multimedia, game, education and communication projects – even if very appealing – were too demanding from the technological point of view, as they would have required complex systems that the school was unable to provide.

The projects of the music section were found to be too focused on music production. Although the students belonged to the music section of the high school, nevertheless they felt the necessity of involving also the students of the other sections. Thus the need to identify more socially shared themes emerged to maximize the communication and the usefulness of the technologies learned.

*Table 1: The ideas proposed by the students for the realisation of the final prototype of 'The Discovery of Interactive Spaces' project.*

Music	Creation/conduction of a musical composition through the tracking of the position of the hands Real-time interaction between two performers of an acoustic instrument and electronic music using the movements of the hands Improvisation/performance where several students activate different types of sound synthesis processes through gestural interaction employing more than one Kinect Through a free choreography the performer – even if not a musician – controls the parameters of a live electronics performance
Multimedia	Real time foley of a video through gestures Interactive multimedia composition through bodily interaction
Game	Flight simulator controlled through arms movements
Education	History lessons with multimedia controlled through bodily movements Live sonification of paintings through gestures
Communication	Sonification of some historical locations of the ancient part of Brescia through the movements of the users



### 3. PERSONÆ: FREE INTERACTIVE SPACE

After further discussion most of the students agreed on the need to stimulate the public on the theme of multiculturalism. This topic is particularly important for students and citizens, since Brescia is the city where the presence of immigrants from different origins has been one of the most significant since at least the 1990s. Cultural integration and the problems related to civil coexistence create a significant impact in everyday life and are therefore deeply felt within the community. Thus the students' approach aimed at communicating a sense of positive cultural integration by fostering reflection through artistic and sensorial stimuli. This aspect demonstrates that students understood that an interactive installation is not only a mere sum of different communication modes, but that it rather welds the potential of technology and content into a unique expressive artefact.

Soon the characteristics of the installation took the form of a large-scale interactive space where users could enter and trigger the playback of sentences in different languages. The students asked their classmates, teachers and international students to collect tongue twisters or characteristic sayings in ten different languages.

Moreover musical transformations of the collected sentences were designed in order to enhance the richness deriving from the meeting of different cultures. This means that the same audio file would be digitally processed according to some previously studied models, such as Luciano Berio's 'Thema (Omaggio a Joyce)' (Di Scipio 2000), Jonathan Harvey's 'Mortuos Plango, Vivos Voco' (Zattra 2019) and Trevor Wishart's 'Vox 5' (Wishart 1988).

Eventually it was agreed that the title of the installation should be 'Personæ', an ancient Latin term that indicated the theatrical mask. This was a device used to amplify or modify the actor's voice and to give it a particular character 'per-sonum', that is through the sound of the voice. The installation is 'free' because it has been offered for free to everybody and because it is the students' free expression. At last, it is an 'interactive space' since the visitors' movements, their spatial proximity and the resulting audio output represent the poetic and expressive core of the installation itself.

#### 3.1 System description

'Personæ' has been conceived as a large-scale interactive space. When the user enters the active area, she is assigned to a couple of audio tracks of a spoken language. The first is the original recording of a sentence in one of the ten languages, and the second is the processed version of the original recording to obtain a musical effect. The two versions are played according to the proximity of users. Thus the presence of multiple users gives life to a melting pot effect emphasizing the coexistence of different languages in the same space.

Figure 2 depicts the system architecture employed for 'Personæ'. An RGB camera hangs from the ceiling and is oriented perpendicularly to the floor. The range of vision of the camera allows the creation of an active area of 3 × 4 m where the presence of a user can be tracked. The students performed several tracking experiments with candles and little light torches to avoid confusion in the detection of the position of many users, as in the case of their excessive proximity. Using the light beam of mobile phones seemed the best and the most practical solution: In a dark environment the intense light of the torch can be easily detected by the system by tracking the brightness values of the

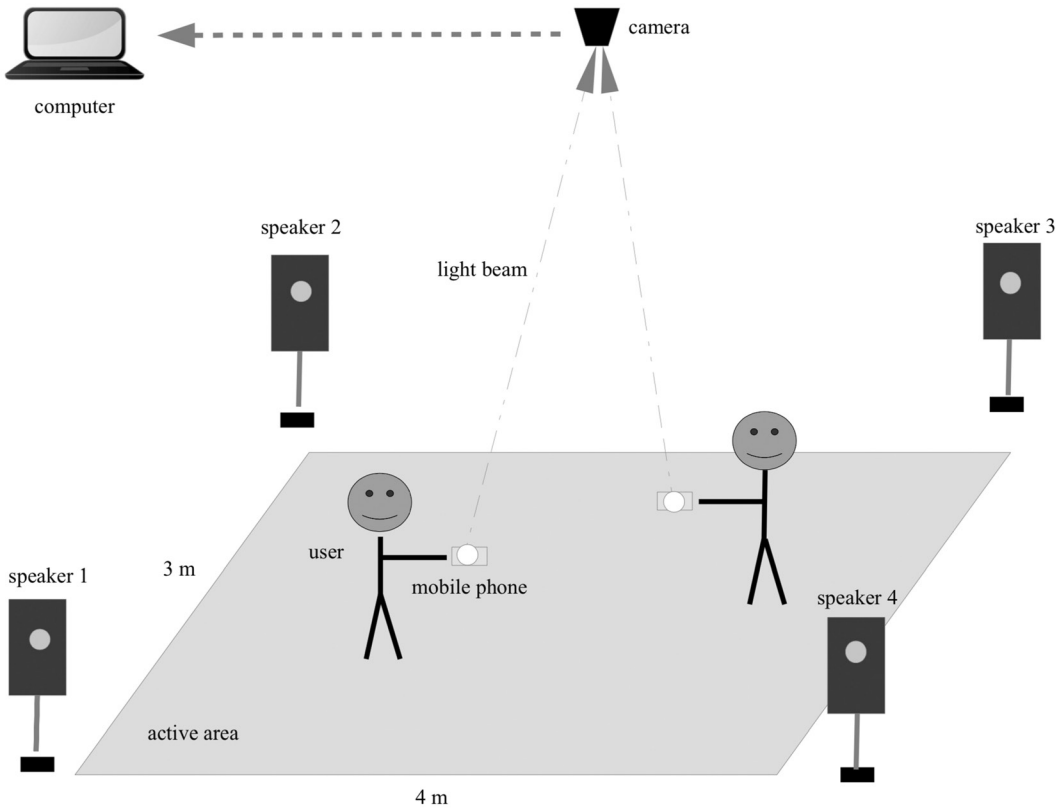

Figure 2: The system architecture of 'Personæ'.

image. The data produced by the blobs of the torch are then processed for audio output and sound spatialization.

### 3.2 Motion tracking and audio files management

The audio/video software was developed into the Cycling '74 MAX environment. The choice of the MAX language was made on the basis of two main advantages:

- using a single programming environment for both video and audio,
- using a programming language that is more understandable to students at their first programming experiences.

The audio/video software was organized in seven different modules (Figure 3): *Inputs*, *Pre-processing*, *Video blob recognition*, *Video blob tracking*, *Audio targeting*, *Audio processing* and *Settings* (audio and video). The *Inputs* module provides the possibility to choose the video source between live webcam, pre-recorded movie file or live LCD drawing. While the first is obviously used during performance or rehearsal, the second and third are useful for testing. The *Pre-processing* module consists of a set of preliminary controls, such as brightness, contrast, saturation and Look Up Table (LUT), particularly

Delivered by Intellect to:

Marcella Mandanici (33327976)

IP: 5.90.73.43

On: Sat, 18 Feb 2023 07:59:29

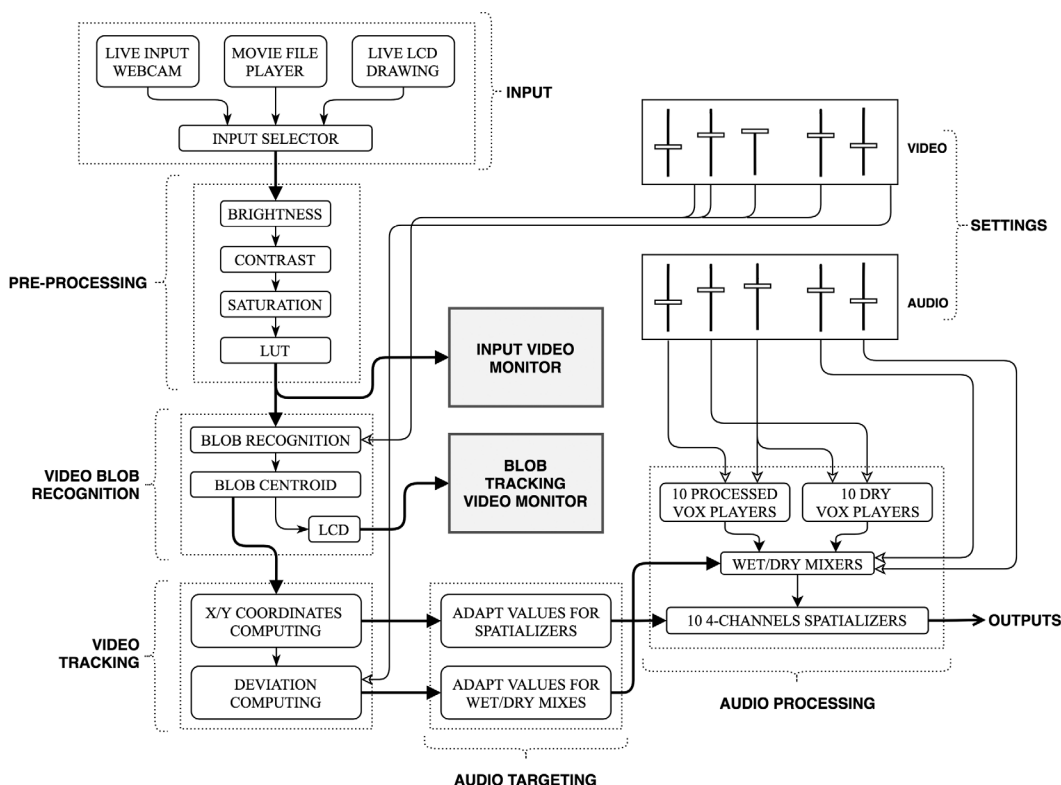

Figure 3: Audio/video software general blocks diagram.

useful for modifying and adapting video signals to the lighting conditions of the room where the performance takes place.

The *Video blob recognition* module converts the video input signal into a binary image and analyses it employing objects from the *cv.jit library* (*cv.jit.label* and *cv.jit.blobs.centroid*) by Jean-Marc Pelletier (2021). The mean and standard deviation for the X–Y coordinates calculated by the *Video tracking* module influence the dry/wet ratio of the tracks being played, following the idea of emphasizing the processed versions in relation to the proximity of people within the performative space. The *Audio targeting* receives the video tracking values and translates them into audio controls of each track being played. In particular, these operations allow to reproduce a language chosen randomly among the ten pre-recorded ones and to assign it to the person who has just entered the playground of the installation. The *Audio processing* module consists of ten instances loaded by the *poly~* object. Each instance reproduces a language in its original version (Vox) and the processed one (Processed Vox), and contains:

- two audio players (with independent time-interpolated gain factor),
- a dry/wet leveller system (for dry signals we mean the original unprocessed speech files, for wet their processed version),
- a quadraphonic spatializer.

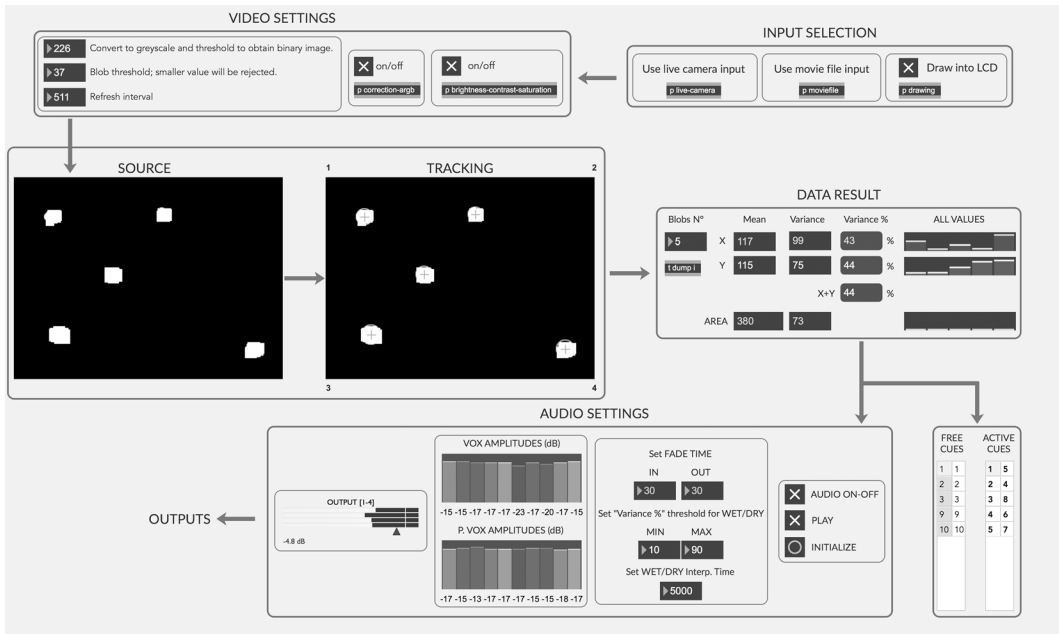

Figure 4: Screenshot of the graphic user interface.

2. See <https://youtu.be/Rffr1XUW74g>. Accessed 10 February 2021.

The *Settings* (audio/video) module allows modification of the fundamental audio and video tracking parameters which are particularly useful for adapting the behaviour of the audio section of the software to the dimensions of the performative space (e.g. the distance between loudspeakers).

As it is entirely programmed as MAX abstraction, the built software can run on any operating system supported by MAX, 32 or 64 bit version. This is particularly useful as each student can use the software having at least MAX 6 runtime installed on their computer. Moreover, the graphic interface (Figure 2a) has been developed to facilitate the direct access to each section of the algorithms (sub-patches), while maintaining clearness and intelligibility that are essential for use by students. In addition to controlling all the parameters, there are two embedded video frames that allow to monitor the incoming video (post *Pre-processing* module) and the tracked blobs.

#### 4. ASSESSMENT

In January 2019 the installation 'Personæ' was premiered at the 'Caffè Letterario' in Brescia.<sup>2</sup> On this occasion we administered an evaluation questionnaire that was filled in by 79 visitors. Four questionnaires were discarded due to compilation errors and thus only 75 of them were analysed.

Out of 75 respondents, 62 per cent were female (age  $M = 35.88$  years,  $SD = 17.98$ ) and the distribution of their degree of education is depicted in Figure 5.

The questionnaire was composed of ten items with close-ended answers on a 1-to-7 Likert scale (see Table 2). The questions were all positive statements concerning the installation evaluation (Q1-5) and students' curriculum integration themes (Q6-10). The participants expressed their opinions on a scale from 1 (strongly disagree) to 7 (strongly agree).

Delivered by Intellect to:

Marcella Mandanici (33327976)

IP: 5.90.73.43

On: Sat, 18 Feb 2023 07:59:29

## Degree of education

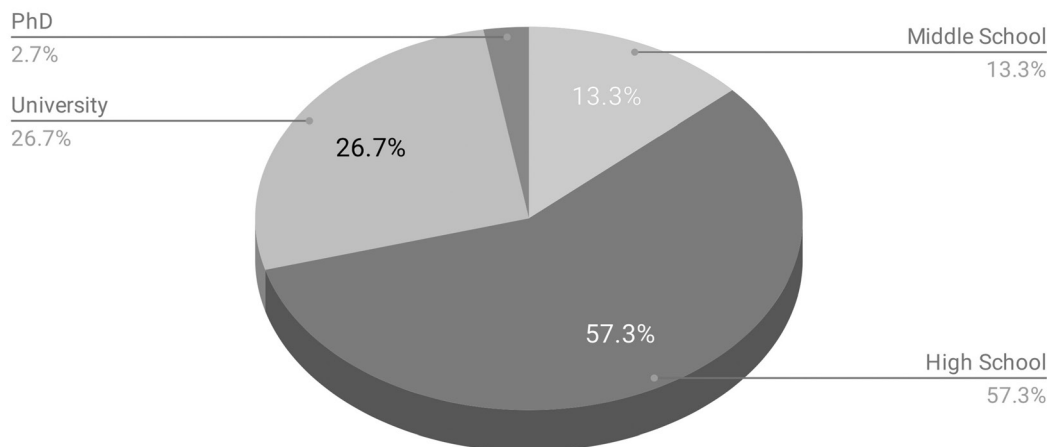

Figure 5: Distribution of degree of education for the respondents to the evaluation questionnaire.

Table 2: Number and text of the questions of the evaluation questionnaire.

Group	Question #	Text
Installation evaluation	Q1	I enjoyed the installation 'Personæ'
	Q2	The message of 'Personæ' is engaging
	Q3	The sound result is engaging
	Q4	The interaction is engaging
	Q5	I had the feeling of changing the sound by exploring the environment
Students' curriculum integration	Q6	Technology contributes to better social communication
	Q7	Experiences like this enrich school life
	Q8	Digital literacy contributes to better student education
	Q9	Current school curricula provide adequate digital literacy
	Q10	Digital literacy should be firmly incorporated into school curricula

Q1 aimed at a general evaluation of the installation, while Q2, Q3 and Q4 focused on particular aspects such as expressivity, sound quality and interaction. Q5 investigated whether the respondents could perceive the relationship between the sound output and the degree of proximity to the other visitors inside the active area, a peculiar design feature of 'Personæ'.

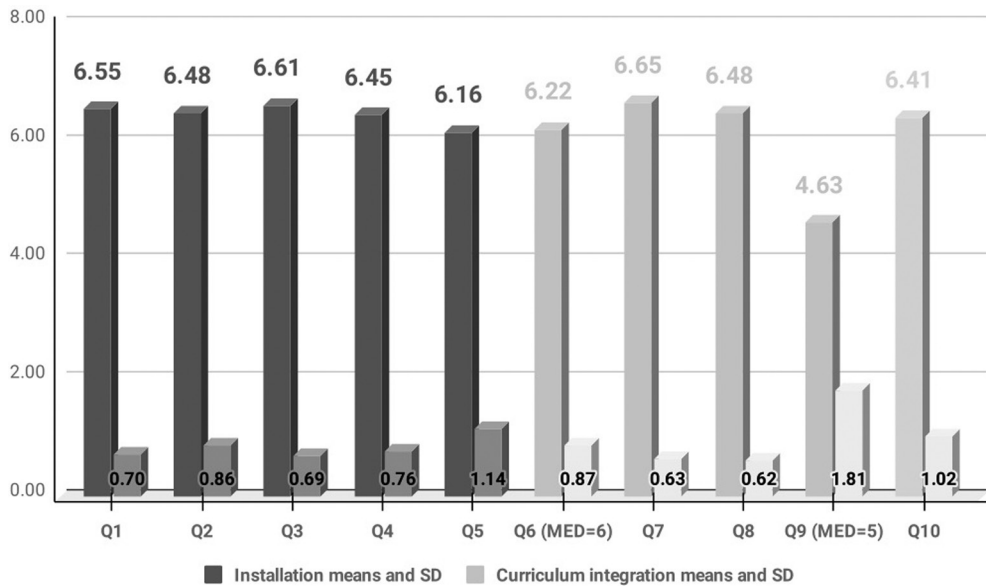

Figure 6: Mean scores and SD for Q1–5 (dark grey) and for Q6–10 (light grey).

The second group of questions concerned wider aspects of technology integration and school curricula. Q6 outlined the potential of technology in the field of social communication, a topic already touched upon in Q2, but here extended to technology in general. Q7 and Q8 pointed out positive aspects of technology integration in schools, while Q9 and Q10 aimed at evaluating some critical insights into current school curricula.

Figure 6 shows the mean scores and standard deviations for Q1–5 (dark grey) and for Q6–10 (light grey).

While the mean scores of Q1–5 are fairly uniform (MED = 7 for all questions), the mean scores of Q6–10 are more varied (MED = 5 for Q9, MED = 6 for Q6 and MED = 7 for all the remaining questions). To verify if the responses to the two groups of questions are statistically significant, we perform a comparison of the total of the means using the Wilcoxon Signed-Rank test, which reports  $z = -4.1362$  and  $p\text{-value} < 0.01$ .

In the second group of questions Q9 is the most critical because it touches the fundamental point of technology integration in school programmes, that is, if current school curricula provide adequate digital literacy. The answers are halfway between a neutral position and a slight agreement, MED = 5 and SD = 1.81, respectively the lowest and the highest values of the sample. Also Q10 (digital literacy should be firmly incorporated into school curricula) obtained MED = 7, with SD = 1.02. The analysis of the mean scores of these two questions compared to the education degree of the respondents shows an opposite trend, as depicted in Figure 7.

#### 4.1 Results discussion

The results presented above seem to indicate that although there is a general consensus about the artistic value of the installation 'Personæ', the opinions

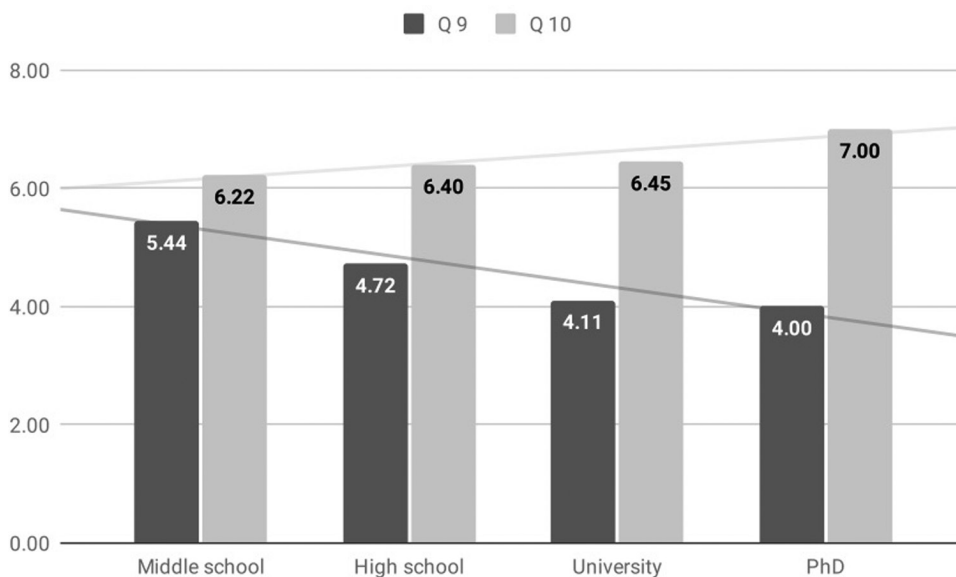

Figure 7: Mean scores for Q9 and 10 subdivided for level of education of the respondents.

about the technology integration themes are rather varied (Q7 and Q9 register respectively the maximum and the minimum of the scores).

Analysing the standard deviations of the answers, we can also discover what are the topics on which the respondents disagree most. In the first group of questions, Q5 has the lowest score of its group and  $SD = 1.14$ . Actually when the installation area was crowded (and this happened most of the time) it was very difficult to make sense of the sound variations produced by proximity of the visitors.

In the second group of questions Q6 and Q9 obtain the lowest median values, while Q9 obtains the lowest mean, median and the highest standard deviation. The theme of social communication (Q6) is a very important topic also in relation to the use of ICT in schools. Although the level of computer and information literacy is higher in students who frequently use the internet and social media (Alkan and Meinck 2016), not all the teachers agree on the use of these technologies in educational contexts (Van Den Beemt et al. 2020). Although Q6 aimed at evaluating the communicative power of 'Personæ', it is possible that respondents interpreted Q6 as a question about the distracting effect of social media in general, and hence they answered accordingly.

The results of Q9 prove that technology integration is still one of the most controversial topics. Actually theories such as TPACK (Technology, Pedagogy and Content Knowledge) describe technology integration as a multifaceted process where content, technology and pedagogy interact at a deep level for the creation of a new form of knowledge (Harris et al. 2009). It is therefore not unlikely that students and teachers will struggle to understand the extent of the changes that technology has brought in teaching and – consequently – agree about the need to revise school curricula accordingly.

From this analysis we can deduce that the general consensus about the installation is not matched by a similar level of uniformity of agreement on some aspects of technology integration. Particularly, the respondents

acknowledge that technology can help enrich school life and improve student education (Q7 and Q8), yet they do not have a clear opinion on the adequacy of school curricula and whether technology should be taught in a stable way, and not occasionally (Q9 and Q10). In this respect, it is worth highlighting the effect of the level of education of the respondents. As depicted in Figure 7, the higher the level of education of respondents, the lower the consensus towards the current grade of technology integration in school curricula. On the other hand, as the educational level increases there is a growing consensus on the need for greater technological integration actions in study programmes. This is not too surprising, given the complexity of the cultural changes brought about by technologies.

#### **4.2 Limitations of the present study and further work**

Designing and realizing a music technology project represented an ideal terrain to stimulate reflection on technological integration, with concrete feedback collected in a real world setting. On the other hand, we acknowledge that this educational experience is a pilot study to define the meaningful themes emerging between the experience and curriculum development. Actually, several relevant issues come into view. The complex relationship between technology integration and teaching approaches highlights the need for novelty in a school routine, which is often perceived as boring and demotivating. To what extent technology can help? How can technology positively impact the crystallised habits of teachers? Conversely, to what extent technology-informed teaching approaches can be considered boring and demotivating?

The lack of students' awareness of some drawbacks in the use of technology at school is not surprising, especially considering that the students who attended the workshops were not accustomed to the use of technology during school time. However, this theme should be further deepened through awareness-raising work by teaching staff.

The workshop participants were all music high school students who have in their curriculum music technology classes, the only subject where the word 'technology' appears. Thus we can assume that these students represent the most advanced group in the use of technologies at school, and it is significant that this happens in connection with music studies. Is it possible to extend this attitude to the study of the arts in general? What are the possibilities of technology integration in other disciplines? How technology integration is perceived in these contexts? These important issues can be further analysed and used to shape more formal assessments in the future.

### **5. CONCLUSION**

In this project, we tried to sensitize the students of a music high school in the use of technologies for social communication, inclusion of disabled people and artistic expression. Exploiting motion tracking devices and technologies, we involved the students in a collective prototyping experience, where they could deal with the complexity of co-designing and realizing a fully working installation. This approach resulted in a successful public presentation of 'Personæ', and very positive inclination and responses by students and parents towards this school experience. Unfortunately the COVID-19 pandemic, that would have come shortly thereafter, has prevented us to present the installation in other contexts, collect further user evaluation data and have follow-up discussions with students and their parents.

Delivered by Intellect to:

Marcella Mandanici (33327976)

IP: 5.90.73.43

On: Sat, 18 Feb 2023 07:59:29



However, the analysis of the questionnaires, fulfilled during the first and only public presentation of 'Personæ', revealed a tension, if not a caution, between the artistic appreciation of the installation and the introduction of possible changes in school curricula, derivable from this educational experience. This is a very important and critical point that denotes an underestimation of the necessity to achieve a higher degree of technology integration in school curricula. Educational activities that involve technology can provide students with effective tools to interpret the future society and should not be further postponed. The reason for the resistance to technology integration can be manifold, ranging probably from the lack of confidence of many teachers to a resilience in the modification of already consolidated teaching practices.

## FUNDING

The project was supported by the National Operation Program (PON) within the framework of 'Fondo Sociale Europeo (FSE)', identification code 10.2.2A-FdRPOC-LO-2018-187.

## REFERENCES

- Agcom (2019), 'Lo stato di sviluppo della scuola digitale', Agcom, 28 February, <https://www.agcom.it/documents/10179/14037496/Studio-Ricerca+28-02-2019/af1e36a5-e866-4027-ab30-5670803a60c2?version=1.0>. Accessed 10 February 2021.
- Alkan, M. and Meinck, S. (2016), 'The relationship between students' use of ICT for social communication and their computer and information literacy', *Large-Scale Assessments in Education*, 4:1, pp. 1–17, <https://doi.org/10.1186/s40536-016-0029-z>. Accessed 10 February 2021.
- Azure Kinect (2021), 'Azure Kinect DK', Azure, <https://azure.microsoft.com/en-us/services/kinect-dk/>. Accessed 10 February 2021.
- Van Den Beemt, A., Thurlings, M. and Willems, M. (2020), 'Towards an understanding of social media use in the classroom: A literature review', *Technology, Pedagogy and Education*, 29:1, pp. 35–55, <https://doi.org/10.1080/1475939X.2019.1695657>. Accessed 10 February 2021.
- Cycling74 (2021), 'Cycling '74', Cycling74, <https://cycling74.com/>. Accessed 10 February 2021.
- European Commission (2019), 'The Digital Economy and Society Index (DESI)', European Commission, <https://digital-strategy.ec.europa.eu/en/library/digital-economy-and-society-index-desi-2019>. Accessed 10 February 2021.
- Gordon, G., Kaplan, D., Lankow, B., Little, D., Sherwin, J., Suter, B. and Thaler, L. (2011), 'Toward an integrated approach to perception and action: Conference report and future directions', *Frontiers in Systems Neuroscience*, 20: 5, <https://doi.org/10.3389/fnsys.2011.00020>. Accessed 10 February 2021.
- Harris, J. M., Mishra, P. and Koehler, M. (2009), 'Teachers' technological pedagogical content knowledge and learning activity types: Curriculum-based technology integration reframed', *Journal of Research on Technology in Education*, 41:4, pp. 393–416, <https://doi.org/10.1080/15391523.2009.10782536>. Accessed 10 February 2021.
- Himonides, E. (2019), 'The misunderstanding of music-technology education: A meta perspective', in G. E. McPherson and G. F. Welch (eds), *Creativities, Technologies, and Media in Music Learning and Teaching: An Oxford Handbook of Music Education*, vol. 5, Oxford: Oxford University Press, <https://doi.org/>

- org/10.1093/oxfordhb/9780199928019.013.0029\_update\_001. Accessed 10 February 2021.
- De Kort, Y. and Ijsselstein, W. (2008), 'People, places, and play: Player experience in a socio-spatial context', *Computers in Entertainment*, 6:2, pp. 1–11, <https://doi.org/10.1145/1371216.1371221>. Accessed 10 February 2021.
- Leap Motion (2021), 'LEAP motion/developer', Leap Motion, <https://developer.leapmotion.com/>. Accessed 10 February 2021.
- Mandanici, M., Altieri, F., Rodà, A. and Canazza, S. (2018), 'Inclusive sound and music serious games in a large-scale responsive environment', *British Journal of Educational Technology*, 49:4, pp. 620–35, <https://doi.org/10.1111/bjet.12630>. Accessed 10 February 2021.
- Mandanici, M., Filippo, R. Di and Delle Monache, S. (2021), 'The discovery of interactive spaces: Learning by design in high school music technology classes', *Technology, Knowledge and Learning*, 26:4, pp. 1131–51, <https://doi.org/10.1007/s10758-020-09464-4>. Accessed 10 February 2021.
- Mergendoller, J., Maxwell, N. and Bellissimo, Y. (2006), 'The effectiveness of problem-based instruction: A comparative study of instructional methods and student characteristics', *Interdisciplinary Journal of Problem-Based Learning*, 1:2, pp. 49–69, <https://doi.org/10.7771/1541-5015.1026>. Accessed 10 February 2021.
- MIUR (2015), 'Piano Nazionale Scuola Digitale (PNSD 2015)', MIUR, <https://www.miur.gov.it/scuola-digitale>. Accessed 10 February 2021.
- MIUR (2017), 'Il programma operativo nazionale 2014–2020', MIUR, 31 January, <http://3.flcgil.stgy.it/files/pdf/20170426/nota-950-del-31-gennaio-2017-avviso-quadro-pon-per-la-scuola.pdf>. Accessed 10 February 2021.
- OpenPTrack (2015), 'Arts: OpenPTrack', Openptrack, <http://openptrack.org/arts/>. Accessed 10 February 2021.
- OsborneTechnologies (2021), 'WizeFloor: Interactive floor for education', OsborneTechnologies, <https://www.osbornetechnologies.co.uk/wizefloor/>. Accessed 10 February 2021.
- Parker, J. (2010), *Algorithms for Image Processing and Computer Vision*, Indianapolis, IN: Wiley Publishing.
- Pelletier, J. M. (2021), 'Computer vision for Jitter', Jean-Marc Pelletier: Media Art, <https://jmpelletier.com/cvjit/>. Accessed 10 February 2021.
- Pure Data (2021), 'Pure Data: Pd community site', Pure Data, <https://puredata.info>. Accessed 10 February 2021.
- Scipio, A. Di (2000), 'Da un'esperienza in ascolto di Phonè e Logos: Testo, suono e struttura in Thema (Omaggio a Joyce) di Berio', *Saggiatore musicale*, 7:2, pp. 325–59.
- SMALLab Learning (2021), 'SMALLab: This is engaged learning', <https://www.smallablearning.com/>. Accessed 10 February 2021.
- Wasenmüller, O. and Stricker, D. (2017), 'Comparison of Kinect v1 and v2 depth images in terms of accuracy and precision', in C. S. Chen, J. Lu, K. K. Ma (eds), *Computer Vision: ACCV 2016 Workshops: ACCV 2016*, Lecture Notes in Computer Science, vol. 10117, Cham: Springer, pp. 34–45, [https://doi.org/10.1007/978-3-319-54427-4\\_3](https://doi.org/10.1007/978-3-319-54427-4_3). Accessed 10 February 2021.
- Welch, G. and Foxlin, E. (2002), 'Motion tracking: No silver bullet, but a respectable arsenal', *IEEE Computer Graphics and Applications*, 22:6, pp. 24–38, <https://doi.org/10.1109/MCG.2002.1046626>. Accessed 10 February 2021.

- Wikipedia (n.d.), 'Microsoft Kinect', Wikipedia, [https://it.wikipedia.org/wiki/Microsoft\\_Kinect](https://it.wikipedia.org/wiki/Microsoft_Kinect). Accessed 10 February 2021.
- Wing, J. (2006), 'Computational thinking', *Communications of the ACM*, 49:3, pp. 33–35, <https://doi.org/10.1145/1118178.1118215>. Accessed 10 February 2021.
- Wishart, T. (1988), 'The composition of "Vox-5"', *Computer Music Journal*, 12:4, pp. 21–27, <https://doi.org/10.2307/3680150>. Accessed 10 February 2021.
- Camurri, A., Volpe, G., Canazza, S., Canepa, C., Roda, A., Zanolta, S. and Foresti, G. L. (2010), 'The "Stanza Logo-Motoria": An interactive environment for learning and communication', in *Proceedings of Sound and Music Computing Conference*, virtual conference, 29 June–1 July, pp. 353–60.
- Zattra, L. (2019), 'Symmetrical collaborations. Jonathan Harvey and his computer music designers', in C. Felici and S. L. Vallauri (eds), *Nuove Musiche*, vol. 4, Pisa: Pisa University Press, pp. 29–57, <https://doi.org/10.12871/97888333922572>. Accessed 10 February 2021.

### SUGGESTED CITATION

Delle Monache, Stefano, Mandanici, Marcella, Alessandretti, Stefano and Di Filippo, Roberto (2022 [2021]), 'Personæ: Users' evaluation of a music technology education project', *Journal of Music, Technology & Education*, 14:2&3, pp. 231–48, [https://doi.org/10.1386/jmte\\_00042\\_1](https://doi.org/10.1386/jmte_00042_1)

### CONTRIBUTOR DETAILS

Stefano Delle Monache received his Ph.D. in science of design in 2012 from Iuav University of Venice. He is currently post-doctoral researcher at the Department of Human-Centered Design, Faculty of Industrial Design Engineering, as well as a Marie Skłodowska-Curie Research Fellow. Stefano has been involved in several EU research projects (FP6-NEST Closing the Loop of Sound Evaluation and Design 2006–09, COST Action on Sonic Interaction Design 2007–11, FP7-FET Sketching Audio Technologies using Vocalizations and Gestures 2014–16, Erasmus+ KA2 INTERactive Environment for MUSIC learning and practicing 2017–20), H2020-MSCA-IF Participatory Designing with Sound 2020–22). His research interests span practices, methods and representations in collaborative sound-driven design, evaluation of sound in interaction and interactive sound models for computational artefacts.

Contact: Delft University of Technology, Landbergstraat 15, 2628 CE Delft, the Netherlands.

E-mail: [s.dellemonache@tudelft.nl](mailto:s.dellemonache@tudelft.nl)

 <https://orcid.org/0000-0003-2210-8410>

Marcella Mandanici is music composer, researcher and full professor of music education at the Music Conservatory of Brescia (Italy). She graduated in piano, harpsichord and composition. She obtained a M.Sc. in music technology (2012) and a Ph.D. in information engineering (2016). She has authored more than 25 papers for international journals, conferences and books. Her research areas are computer-supported music education; sound and music computing; interfaces for music production, education and rehabilitation.

Contact: Music Conservatory 'L. Marenzio', p.tta A.B. Michelangeli 1, 25121  
Brescia, Italy.  
E-mail: marcella.mandanici@consbs.it

 <https://orcid.org/0000-0003-1863-4178>

Stefano Alessandretti is a composer, live electronics interpreter and professor of musical informatics at 'Luca Marenzio' Conservatory of Music in Brescia. He graduated with honour in composition and in sound direction and live electronics at the Conservatory of Venice and in electronic music at the Conservatory of Florence. He is a member and artistic director of ensemble\_Codec and member of the editorial board of *Musica/Tecnologia*. His research interests include live electronics, transmedia composition and digital sound processing.

Contact: Music Conservatory 'L. Marenzio', p.tta A.B. Michelangeli 1, 25121  
Brescia, Italy.  
E-mail: stefano.alessandretti@consbs.it

 <https://orcid.org/0000-0001-5411-7376>

Roberto Di Filippo obtained cum laude the II level academic diploma in sound technology with a focus on composition at the G.Verdi Conservatory in Milan; graduated in piano with Maria Isabella De Carli and in music didactics at the Luca Marenzio. He is active in the fields of electronic music, multimedia, art installations, video art, cinema and theatre and teaches music technologies at the Veronica Gambara Musical High School in Brescia where he carries out research activities in the field of technologies for music and teaching.

Contact: Liceo Musicale Veronica Gambara, Via Veronica Gambara 3, 25121  
Brescia, Italy.  
E-mail: roberto.difilippo@liceogambara.edu.it

 <https://orcid.org/0000-0002-0504-8463>

Stefano Delle Monache, Marcella Mandanici, Stefano Alessandretti and Roberto Di Filippo have asserted their right under the Copyright, Designs and Patents Act, 1988, to be identified as the authors of this work in the format that was submitted to Intellect Ltd.

---