

A Comparative Techno-Economic Assessment of Alternative Fuels in SOFC Systems for Cruise Ships

Pina, E.A.; van Veldhuizen, B.N.; Maréchal, François; van Herle, J.

DOI

[10.1149/11106.2459ecst](https://doi.org/10.1149/11106.2459ecst)

Publication date

2023

Document Version

Final published version

Published in

ECS Transactions

Citation (APA)

Pina, E. A., van Veldhuizen, B. N., Maréchal, F., & van Herle, J. (2023). A Comparative Techno-Economic Assessment of Alternative Fuels in SOFC Systems for Cruise Ships. *ECS Transactions*, 111(6), 2459-2472. <https://doi.org/10.1149/11106.2459ecst>

Important note

To cite this publication, please use the final published version (if applicable). Please check the document version above.

Copyright

Other than for strictly personal use, it is not permitted to download, forward or distribute the text or part of it, without the consent of the author(s) and/or copyright holder(s), unless the work is under an open content license such as Creative Commons.

Takedown policy

Please contact us and provide details if you believe this document breaches copyrights. We will remove access to the work immediately and investigate your claim.

Green Open Access added to TU Delft Institutional Repository

'You share, we take care!' - Taverne project

<https://www.openaccess.nl/en/you-share-we-take-care>

Otherwise as indicated in the copyright section: the publisher is the copyright holder of this work and the author uses the Dutch legislation to make this work public.

A Comparative Techno-Economic Assessment of Alternative Fuels in SOFC Systems for Cruise Ships

To cite this article: Eduardo Antonio Pina *et al* 2023 *ECS Trans.* 111 2459

View the [article online](#) for updates and enhancements.

You may also like

- [Modeling and analysis of the solar photovoltaic levelized cost of electricity \(LCoE\) - case study in Kupang](#)
Rusman Sinaga, Nonce F. Tuati, Marthen D.E. Beily *et al.*
- [Pentacene Coated Atop of Ultrathin InN Gas Sensor Device for the Selective Sensing of Ammonia Gas for Liver Malfunction Application](#)
Sujeet Kumar Rai, Fushan Yang, K. W. Kao *et al.*
- [Plasma catalytic ammonia synthesis: state of the art and future directions](#)
Maria L Carreon



245th ECS Meeting • May 26-30, 2024 • San Francisco, CA

[Learn more & submit!](#)

Present your work at the leading electrochemistry & solid-state science conference.

Network with academic, government, and industry influencers!

Submit abstracts by December 1, 2023



A Comparative Techno-Economic Assessment of Alternative Fuels in SOFC Systems for Cruise Ships

E. A. Pina^{a,b,c}, B. N. van Veldhuizen^d, F. Maréchal^a, and J. van Herle^b

^a Industrial Process and Energy Systems Engineering, Faculty of Engineering Sciences, École Polytechnique Fédérale de Lausanne, Sion, Valais 1950, Switzerland

^b Group of Energy Materials, Faculty of Engineering Sciences, École Polytechnique Fédérale de Lausanne, Sion, Valais 1950, Switzerland

^c Group of Thermal Engineering and Energy Systems, Aragón Institute of Engineering Research, Department of Mechanical Engineering, University of Zaragoza, Zaragoza, 50009, Spain

^d Department of Marine Technology, Delft University of Technology, Mekelweg 5, 2628 CD Delft, Netherlands

This study presents the techno-economic analysis of a 100 kW_e Solid Oxide Fuel Cell (SOFC) system for maritime applications fueled by methane, methanol, diesel, ammonia, and hydrogen. Two system configurations are considered for each fuel considering cathode off-gas recirculation (COGR) implementation to improve waste heat recovery both in terms of quantity and quality. The economic benefit of COGR is verified for all fuels, especially for methanol, hydrogen, and diesel, which present Levelized Cost of Exergy (LCOEx) reductions of about 10%, 9%, and 6%, respectively. Ammonia and methanol have the lowest LCOEx of about 0.260 EUR/kWh and 0.270 EUR/kWh, respectively, while hydrogen has the highest LCOEx of about 0.430 EUR/kWh. The sensitivity analyses suggest that fuel purchase cost, stack lifetime, and annual interest rate are the three parameters with the highest influence on the system cost. Overall, ammonia and methanol are the most promising fuels.

Introduction

Maritime transportation accounts for about 2.9% of global greenhouse gas (GHG) emissions, according to the fourth GHG study by the International Maritime Organization (IMO) (1). In the period from 2012 to 2018, shipping emissions have increased by almost 10%. Facing growing political and societal pressure, the IMO has established GHG emissions reduction targets consistent with the Paris Agreement temperature goals, aiming to reduce the total annual GHG emissions by at least 50% by 2050 compared to 2008 levels. Furthermore, in 2016, IMO added stringent limits on NO_x emissions in dedicated Emission Control Areas and, since 2020, the IMO set a limit on the sulfur content of the used fuel of 0.5% (2,3). In this context, alternative fuels and novel power generation technologies are needed to allow the maritime industry to comply with forthcoming regulations, as well as to fulfil decarbonization targets within the European and global markets.

Solid Oxide Fuel Cell (SOFC) systems are considered a high-potential solution for reducing carbon and pollutant emissions in ships, especially for long-distance shipping, for which batteries or hydrogen are not able to satisfy the range requirements (4). Since the conversion efficiency of SOFC is higher than for traditional marine engines, even when fueled with natural gas, GHG emissions can be significantly reduced. Furthermore, there are virtually no NO_x, SO_x, particulate matter, or methane emissions. Fuel flexibility is another advantage of SOFCs. Alternative marine fuels offer a way to reduce or even phase out GHG emissions and other air pollutants. In preceding research, van Veldhuizen et al. concluded from a multi-criteria analysis covering availability, technical feasibility, operability, cost, and environmental impact that methane, methanol, diesel, ammonia, and hydrogen can be considered as potential fuels for marine SOFC systems (5).

To evaluate whether SOFC power plants can offer a feasible solution to reduce ship emissions, a techno-economic assessment is necessary. Kirstner et al. compared internal combustion engines (ICEs) and LNG-fueled SOFCs for a large cruise ship (6). The analysis included investment, fuel, and maintenance costs. The total annual cost, the power plant size and the reduction in emissions were used as performance indicators. It was concluded that the SOFC technology is viable from an economic perspective because the high conversion efficiency results in a reduction of total cost of ownership. The analysis did not include, however, heat integration. Baldi et al. suggest that matching the heat supply of the SOFC and the heat demand of the ship is also necessary to successfully assess the effectiveness of a marine SOFC power plant, especially for applications with high heat demand, such as cruise ships (4). Rivarolo et al. compared ICE, Polymer Electrolyte Fuel Cell (PEFC) and SOFC for reducing the emissions of a small passenger ship and a cruise ship (7). Marine diesel oil, hydrogen, LNG, methanol, and ammonia were included as fuels. They developed a multi-criteria scoring system based on volume, weight, cost and emissions for the energy storage and power production. Korberg et al. (8) made a techno-economic assessment of ICE, SOFC, PEFC and batteries for four different ship types using different non-fossil fuels. The total cost of ownership per year was used as indicator, which included fuel production, propulsion system, and onboard fuel storage. The volume of the propulsion system was also included in the cost as reduced cargo space.

Cathode off-gas recirculation (COGR) could offer significant advantages for marine SOFC systems. It was found by van Veldhuizen et al. that employing COGR resulted in a lower primary airflow, from 19.1% to 63.7% depending on the selected fuel (9). This reduces the size of the air pre-heater, which is the largest heat exchanger in the system. Moreover, a lower primary airflow reduces the size of air ducting and exhaust piping. Finally, since less air needs to be heated, the exhaust gas after the combustor is of a higher quality, which improves the heat recovery capacity. Since the systems proposed herein are evaluated for cruise ships, which are limited in space and have high heat demands, it is proposed to include COGR in the present analysis to assess its potential advantage.

Although several techno-economic analyses were already performed for ships powered with SOFCs, the number of fuels that were compared for SOFCs specifically is limited. Different scopes, assumptions, and application cases make it difficult to compare the different assessments, even more because no uniform performance indicator is used. This study contributes by systematically assessing the cost performance of various SOFC systems consuming different fuels. The objective of this study is thus to perform a detailed techno-economic assessment of 100 kW_e SOFC systems for five fuels (i.e. methane,

methanol, diesel, ammonia, and hydrogen). Two scenarios are considered regarding the implementation or not of COGR. The analysis is based on several Key Performance Indicators (KPIs), including the total annual cost, capital expenditures, operational expenditures, and leveled cost of exergy.

System description

The techno-economic assessment carried out in this study is based on a modular 100 kW_e SOFC system. The different systems for the five selected fuels are shown in Figure 1. In addition, COGR was proposed to improve heat regeneration both in terms of quantity (kWh) and quality (°C). As a result, a total of 10 SOFC systems were evaluated: for each fuel, one system with COGR and one system without it. A schematic overview of COGR implementation is shown in Figure 2.

The systems are composed of an SOFC stack and Balance of Plant (BoP) components. The BoP accounts for all pieces of equipment that are required to run the SOFC stack. The fuel is supplied by a pump or a compressor, heated, and fed to the anode. Air is supplied with a blower, preheated, and fed to the cathode. Co-flow planar SOFCs convert the fuel into power and flue gas. The anode and cathode outlets flow directly into a combustor. Its exhaust leads through the counterflow heat exchangers that preheat the fuel and air. Remaining heat is recovered from the exhaust stream to produce both saturated steam (180 °C) and hot water (90 °C). Additional components are required for the specific fuels, such as evaporators, reformers, and heat exchangers. The main technical parameters of the components are shown in TABLE I. It is worth noting that the stack lifetime was estimated considering a 50,000-h stack lifetime and nominal operation throughout the year (8760 h).

In previous work, a 1D SOFC model and the software Cycle Tempo were used to thermodynamically simulate the system for the five different fuels (9). An extensive description of the SOFC systems and models used is provided in that study. TABLE II and TABLE III provide the main operation parameters for systems without and with COGR, respectively. It is important to highlight that the systems produce different amounts of electricity, steam, and hot water. Further details can be found in (9).

TABLE I. Main technical data of components.

Parameter	Symbol	Unit	Value
<i>SOFC stack</i>			
Cell area	A_{stack}	m ²	31.76
Stack lifetime	$n_{yr,stack}$	yr	5
Cell voltage	V_{ref}	V	0.80
<i>Blower</i>			
Mechanical efficiency	η_{blower}	-	0.80
<i>Pump</i>			
Mechanical efficiency	η_{pump}	-	0.60
<i>After Burner</i>			
Pressure ratio P_{out}/P_{in}	P_r	-	0.99

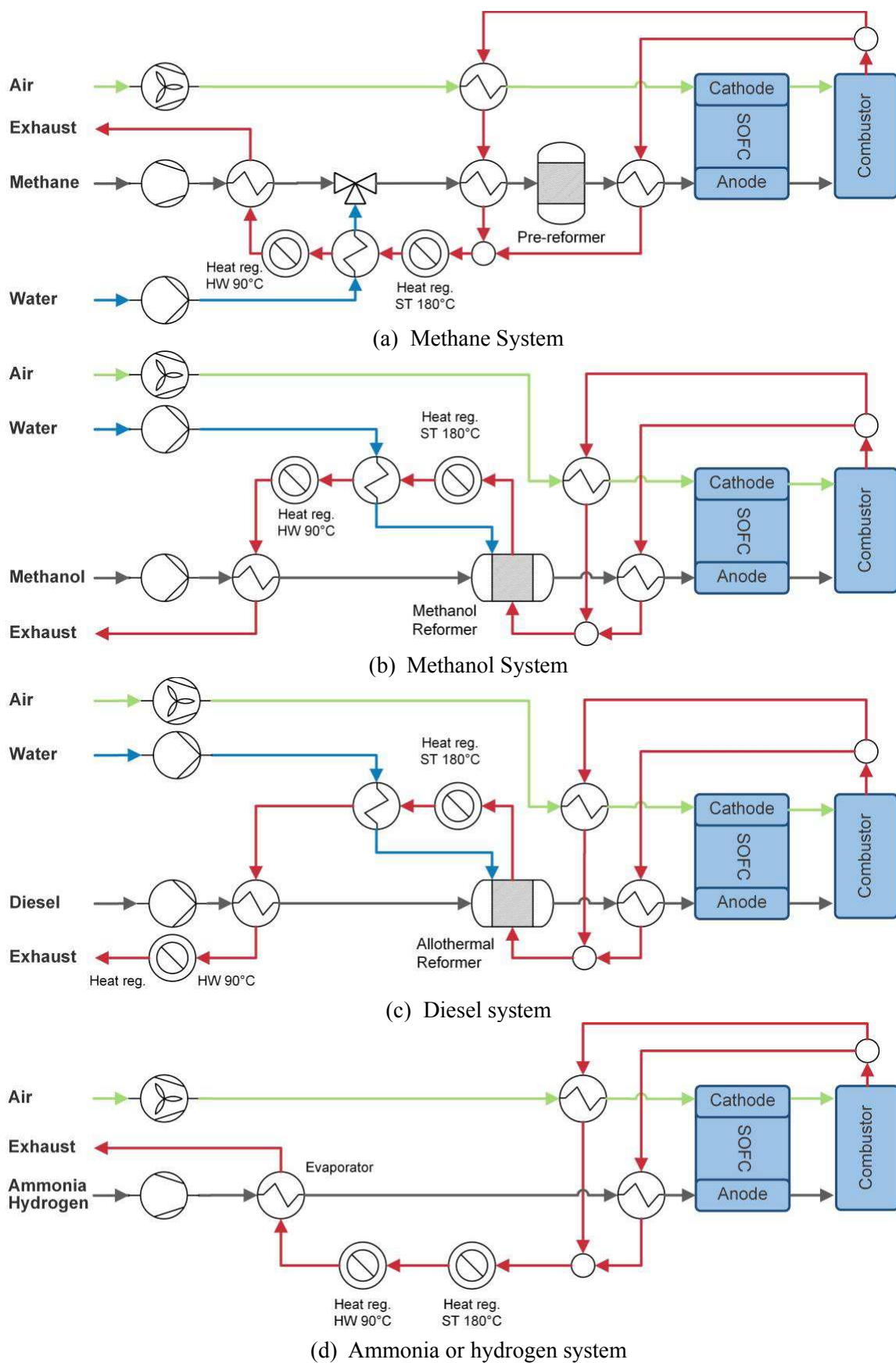

Figure 1. Schematic overview of SOFC systems for various fuels. Source: (9).

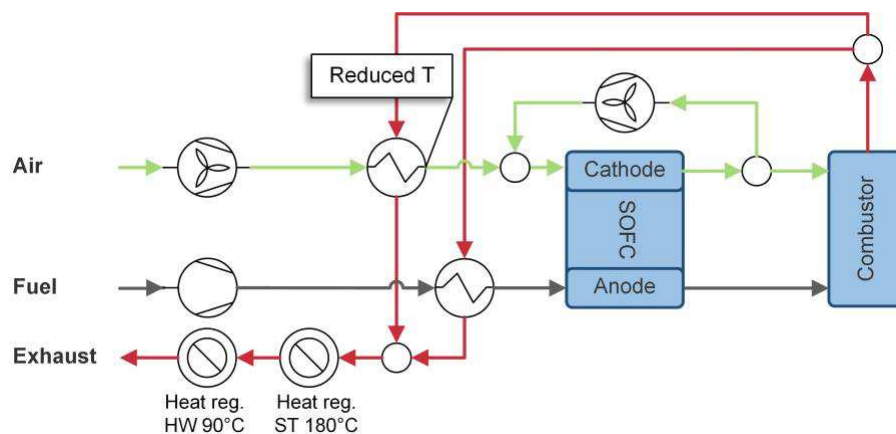

Figure 2. Schematic overview of applied cathode recirculation loop. Source: (9).

Economic model

TABLE IV provides the general parameters used for all systems. The results of the techno-economic analysis performed in this work are expressed in terms of the total annual cost (TOTEX) and the levelized cost of exergy (LCOEX). All costs are given in Euros (EUR) and are updated to the year 2021. Whenever necessary, the factor f_{EUR} was used to convert from U.S. Dollar into Euro.

TABLE II. Main operation parameters for systems without COGR.

Parameter	Symbol	Unit	S1 Methane	S2 Methanol	S3 Diesel	S4 Ammonia	S5 Hydrogen
<i>System</i>							
SOFC net power production	W_{SOFC}	kW _e	83.48	79.90	79.76	97.57	96.10
Steam production	Q_{ST}	kW	14.33	-	-	18.25	-
Hot water production	Q_{HTW}	kW	5.22	24.4	19.94	30.22	52.17
Fuel consumption	F_{fuel}	kW	143.75	163.53	154.48	177.11	204.00
Fuel mass flow rate entering	m_{Fuel}	kg/s	0.003	0.008	0.004	0.009	0.002
Electrical efficiency of the system	η_e	-	0.591	0.526	0.5293	0.5612	0.4902
<i>SOFC</i>							
Current density	J_{ref}	A/cm ²	0.3483	0.3526	0.3352	0.4075	0.4010
<i>Blower</i>							
Air blower power	$W_{blower,air}$	kW _e	1.47	5.98	1.98	1.82	3.89
Fuel blower power	$W_{blower,fuel}$	kW _e	0.02	-	-	-	0.02
<i>Pump</i>							
Fuel pump power	$W_{pump,fuel}$	kW _e	-	0.13	0.01	-	-
Water pump power	$W_{pump,water}$	kW _e	-	-	0.02	-	-
<i>After Burner</i>							
Outlet exhaust mass flow rate	$m_{ab,exhaust}$	kg/s	0.256	0.553	0.350	0.314	0.652
Outlet exhaust temperature	$T_{ab,exhaust}$	°C	874.6	816.2	842.8	884.0	814.0

TABLE III. Main operation parameters for systems with COGR.

Parameter	Symbol	Unit	S6	S7	S8	S9	S10
			Methane	Methanol	Diesel	Ammonia	Hydrogen
<i>System</i>							
SOFC net power production	W_{SOFC}	kW _e	82.96	79.45	83.21	96.84	93.96
Steam production	Q_{ST}	kW	21.38	39.85	2.29	30.72	59.61
Hot water production	Q_{HTW}	kW	0.94	8.88	16.6	23.2	23.12
Fuel consumption	F_{fuel}	kW	142.98	160.67	144.92	176.02	200.96
Fuel mass flow rate entering	m_{Fuel}	kg/s	0.003	0.008	0.003	0.009	0.002
Electrical efficiency of the system	η_e	-	0.591	0.526	0.589	0.561	0.490
<i>SOFC</i>							
Current density	J_{ref}	A/cm ²	0.3465	0.3464	0.3450	0.4049	0.4039
<i>Blower</i>							
Air blower power	$W_{blower,air}$	kW _e	1.19	2.44	1.17	1.36	1.41
Fuel blower power	$W_{blower,fuel}$	kW _e	0.02	-	-	-	0.02
COGR power	$W_{blower,COG}$	kW _e	0.36	2.49	0.97	0.57	3.13
<i>Pump</i>							
Fuel pump power	$W_{pump,fuel}$	kW _e	-	0.14	0.01	-	-
Water pump power	$W_{pump,water}$	kW _e	-	-	0.01	-	-
<i>After Burner</i>							
Outlet exhaust mass flow rate	$m_{ab,exhaust}$	kg/s	0.209	0.207	0.209	0.238	0.237
Outlet exhaust temperature	$T_{ab,exhaust}$	°C	898.0	900.7	900.9	899.5	899.6

TABLE IV. Main input parameters used for all systems.

Parameter	Symbol	Unit	Value	Reference
System lifetime	nyr	yr	25	(10)
Annual operating hours	N_h	h	8760	-
Annual production volume	P_{annual}	m ²	15,000	-
Annual interest rate	i	yr ⁻¹	0.07	(11)
Capital Recovery Factor	CRF	yr ⁻¹	0.086	-
Current year for equipment cost update	-	-	2021	-
Total module factor	$f_{TotalModule}$	-	1.18	(12)
Grassroots factor	$f_{GrassRoots}$	-	0.35	(12)
Maintenance factor	f_{main}	-	1.06	(11)
Exchange rate from USD to EUR	f_{EUR}	-	0.949	(13)

The total annual cost $TOTEX$ is calculated as the sum of the annual investment cost $CAPEX$ and the annual operation cost $OPEX$. The $CAPEX$ is obtained by multiplying the capital recovery factor CRF by the sum of the grassroots cost C_{GR} (or total plant investment cost) and the stack replacement cost C_{SR} (Eq. 1). The CRF is a function of the annual interest rate i and the system lifetime nyr (Eq. 2). The grassroots cost C_{GR} corresponds to the cost for a new installation, which is calculated by adjusting the bare module cost C_{BM} for both total module factor $f_{TotalModule}$ and grassroots factor $f_{Grassroots}$ (Eq. 3). The $f_{TotalModule}$ can include different cost components, such as contingency and legal fees. The C_{BM} of the plant is calculated as the sum of the bare module cost $C_{BM,t}$ of each piece of equipment t (Eq. 4). In turn, the $C_{BM,t}$ corresponds to the sum of direct and indirect costs and is calculated by multiplying the equipment purchase cost $C_{eq,t}$ by a bare module factor $f_{BM,t}$ that accounts

for indirect costs (e.g. freight, construction overhead, contractor engineering) and installation costs (Eq. 5). The purchase cost $C_{eq,t}$ of each piece of equipment t is calculated using cost functions obtained from the scientific literature. For the stack replacement cost C_{SR} , the bare module cost of the SOFC is multiplied by the number of stack replacements n_{stacks} required for the project duration (Eq. 6). The n_{stacks} is estimated based on the system lifetime nyr of 25 years and the SOFC stack lifetime nyr_{stack} of 5 years; thus, 4 stacks are required ($n_{stacks} = 4$) to replace the first one initially installed and accounted for in the C_{GR} .

$$CAPEX = CRF \cdot (C_{GR} + C_{SR}) \quad \text{Eq. 1}$$

$$CRF = \frac{i \cdot (1 + i)^{nyr}}{(1 + i)^{nyr} - 1} \quad \text{Eq. 2}$$

$$C_{GR} = (f_{TotalModule} + f_{Grassroots}) \cdot C_{BM} \quad \text{Eq. 3}$$

$$C_{BM} = \sum_t C_{BM,t} \quad \text{Eq. 4}$$

$$C_{BM,t} = f_{BM,t} \cdot C_{eq,t} \quad \text{Eq. 5}$$

$$C_{SR} = n_{stacks} \cdot C_{BM,SOFC} \quad \text{Eq. 6}$$

Cost functions for the equipment purchase cost $C_{eq,t}$ were collected from the literature, mainly from classical chemical engineering handbooks (12), and project reports (14–16), in the case of the SOFC. The $C_{eq,t}$ is formulated considering: (i) the size of the component, which may be given in any relevant functional unit, such as area (m^2) for the heat exchangers or power capacity (kW_e) for the SOFC; and (ii) the level or scenario representing the maturity of the technology. In the case of the SOFC, its maturity level was represented by the annual production volume of SOFC P_{annual} in m^2 . By contrast, BoP components were assumed to be commercially available, and the cost estimation was carried out with the six-tenth rule and/or cost functions obtained from the literature.

Given that the purchase costs of the components are obtained from various sources published in different years, the $C_{eq,t}$ must be updated to the current year. This work uses the Chemical Engineering Plant Cost Index (CEPCI). For each piece of equipment, its cost is updated through the $f_{CEPCI,t}$ factor, which is calculated as the ratio of the CEPCI in the current year to the CEPCI in the reference year.

The OPEX is calculated as the sum of the fuel consumption cost C_{fuel} and the maintenance cost C_{main} (Eq. 7). The C_{fuel} is expressed by Eq. 8, where N_h is the annual operating hours of the system, c_{fuel} is the unit cost of fuel, \dot{m}_{fuel} is the mass flow rate of fuel, and LHV_{fuel} is the lower heating value of the fuel. The C_{main} is estimated through a maintenance factor f_{main} that multiplies the total equipment investment cost of the plant, and by dividing the result by the plant lifetime nyr (Eq. 9).

$$OPEX = C_{main} + C_{fuel} \quad \text{Eq. 7}$$

$$C_{fuel} = N_h \cdot c_{fuel} \cdot \dot{m}_{fuel} \cdot LHV_{fuel} \quad \text{Eq. 8}$$

$$C_{main} = f_{main} \cdot \frac{\sum_t C_{eq,t}}{nyr} \quad \text{Eq. 9}$$

The fuel price and Lower Heating Value (LHV) of the fuels are shown in TABLE V. It must be noted that the values considered for ammonia and hydrogen correspond to green ammonia (solar and wind energy sources) and green hydrogen (wind electrolysis).

TABLE V. Purchase price and Lower Heating Value of selected fuels.

Fuel	Fuel price [EUR/kWh]	Cost reference	LHV [kJ/kg]
Methane	0.087	(17), (18)	50,000
Methanol	0.068	(17)	19,900
Diesel	0.083	(17)	42,600
Ammonia	0.088	(19)	18,650
Hydrogen	0.150	(20)	120,210

The LCOEx is a good alternative to the typically used levelized cost of electricity for systems that produce different types of energy services (e.g. electricity and thermal energy at different temperature levels). Exergy can be defined as the maximum amount of useful work that can be obtained from a system as it is brought into thermodynamic equilibrium with a specified reference environment. Therefore, exergy is a measure of the usefulness, value, or quality of an energy form. The *LCOEx* can be evaluated as the ratio of the *TOTEX* to the total annual exergy produced (Eq. 10). In the case of electricity, its exergy content is equal to its energy content. By contrast, for thermal energy flows, the relationship between exergy and energy is given by the Carnot factor, which is a function of the average thermodynamic temperature of the energy flow and the reference ambient temperature (21).

$$LCOEx = \frac{TOTEX}{\dot{W}_{net} + \dot{Q}_{ST}^b + \dot{Q}_{HTW}^b} \quad \text{Eq. 10}$$

where \dot{W}_{net} , \dot{Q}_{ST}^b , and \dot{Q}_{HTW}^b represent the annual net electricity, steam, and hot water production in terms of exergy.

Results and discussion

Fuel and COGR evaluation

This section reports the results of the techno-economic analysis of the 100 kW_e SOFC modules described in Section 2. The main results for systems without and with COGR are provided in TABLE VI and TABLE VII, respectively. From the *TOTEX* perspective, the best fuels were methanol and diesel, while hydrogen performed the worst. The *LCOEx* ranged between 0.260 EUR/kWh (S9) and 0.430 EUR/kWh (S5). After S9, the two systems with the most competitive *LCOEx* were S7 and S8. The tables also present the specific equipment purchase cost of each system. It is interesting to note that, when considering the specific investment cost in EUR/kW_e, S9 and S10 were the ones with the best economic performances, which can be explained by the absence of reformer.

TABLE VI. Main results for systems without COGR.

Result	S1	S2	S3	S4	S5
	Methane	Methanol	Diesel	Ammonia	Hydrogen
Grassroots cost, EUR	638,889.26	659,678.60	585,745.87	495,251.05	602,411.57
Stack replacement cost, EUR	678,923.35	678,923.35	678,923.35	678,923.35	678,923.35
CAPEX, EUR/yr	113,082.18	114,866.13	108,521.92	100,756.51	109,952.01
Fuel, EUR/yr	109,554.75	97,411.55	112,319.32	136,530.56	268,056.00
Maintenance, EUR/yr	5,585.92	5,687.89	5,079.23	4,832.17	5,698.49
OPEX, EUR/yr	115,140.67	103,099.44	117,398.55	141,362.72	273,754.49
TOTEX, EUR/yr	228,222.86	217,965.57	225,920.47	242,119.24	383,706.50
LCOEx, EUR/kWh	0.30	0.30	0.31	0.26	0.43
Specific investment cost C_{eq} , EUR/kW _e	1,578.14	1,678.95	1,501.92	1,168.05	1,398.53
Exergy production, kWh	87.04	82.60	81.96	104.71	101.87

TABLE VII. Main results for systems with COGR.

Result	S6	S7	S8	S9	S10
	Methane	Methanol	Diesel	Ammonia	Hydrogen
Grassroots cost, EUR	639,021.84	591,239.54	577,713.80	492,029.92	508,419.88
Stack replacement cost, EUR	678,923.35	678,923.35	678,923.35	678,923.35	678,923.35
CAPEX, EUR/yr	113,093.56	108,993.33	107,832.68	100,480.11	101,886.54
Fuel, EUR/yr	108,967.92	95,707.91	105,368.43	135,690.30	264,061.44
Maintenance, EUR/yr	5,512.38	4,900.87	4,834.00	4,703.01	4,712.61
OPEX, EUR/yr	114,480.30	100,608.78	110,202.43	140,393.31	268,774.05
TOTEX, EUR/yr	227,573.86	209,602.11	218,035.12	240,873.41	370,660.59
LCOEx, EUR/kWh	0.30	0.27	0.29	0.26	0.39
Specific investment cost C_{eq} , EUR/kW _e	1,567.13	1,454.83	1,370.14	1,145.39	1,182.91
Exergy production, kWh	87.52	88.73	85.52	105.80	108.93

Looking into the *TOTEX* composition, *CAPEX* and *OPEX* were about equally distributed for methane, methanol, and diesel; on the other hand, hydrogen and ammonia showed higher shares of *OPEX*, meaning that those systems would be more susceptible to variations in fuel purchase prices, such as the decrease in green hydrogen and green ammonia production costs. In addition, the *OPEX* of the systems were dominated by fuel purchase cost. Considering the *CAPEX*, the stack replacement cost was the same for all systems, as the stack lifetime of 5 years did not change. By contrast, the grassroots costs did vary according to the fuel and to the presence of COGR.

Figure 3 depicts the breakdown of the bare module cost of the system into its components. The SOFC was the component with the highest share in all cases, ranging between about 60% (S2 methanol) and 80% (S4 and S9 ammonia) of the total bare module cost, followed by the reformer, which is only present for systems fueled with methane, methanol and diesel, and the heat exchangers. It is interesting to note the trade-off between the configurations without and with COGR, where the additional cost of the COGR blower is more than compensated by reduction in the cost of the heat exchangers.

Figure 4 shows, for each system, the relation between the exergy produced and the corresponding *TOTEX*. This figure highlights the role of COGR on reducing the *TOTEX* and increasing the exergy production for all systems. This effect is especially noticeable for hydrogen, methanol, and diesel, respectively.

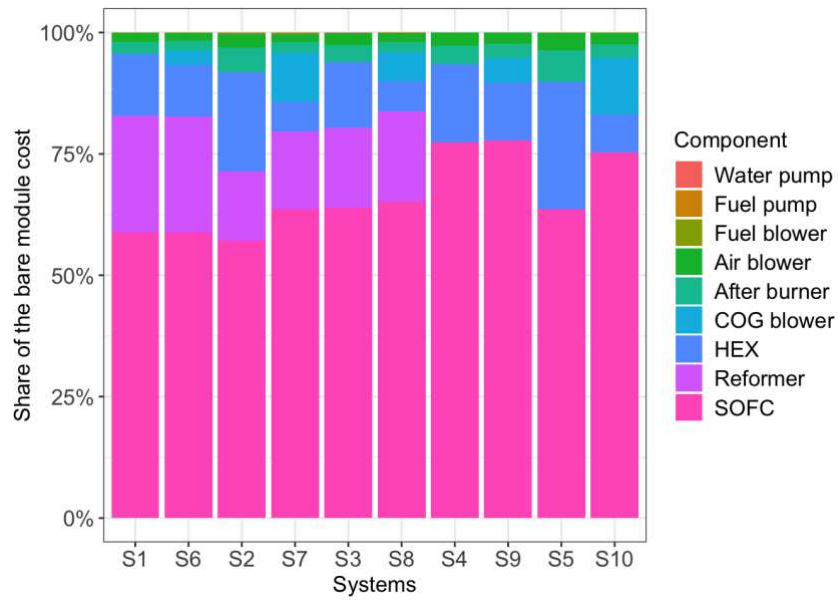

Figure 3. Component's share in the bare module cost of each system.

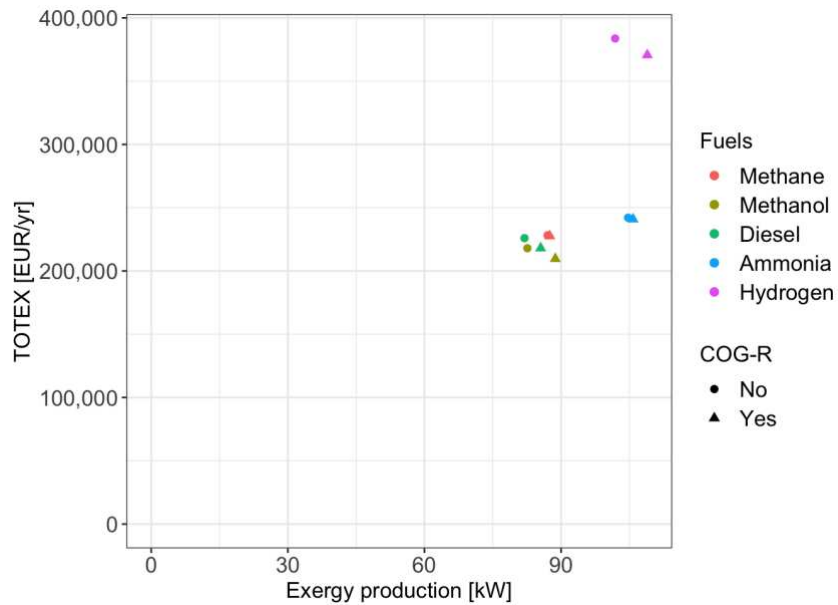

Figure 4. Total annual cost and exergy production for each system.

Sensitivity analysis for systems with COGR

For the sensitivity analysis, the following parameters were varied to evaluate their influence on the *LCOEx* of the SOFC systems: (i) fuel price; (ii) annual interest rate; and (iii) SOFC stack lifetime. For the sake of conciseness, the analysis will focus on the systems with COGR, given their technical and economic attractiveness.

Figure 5 (a) depicts the impact of varying the fuel purchase price c_{fuel} within a range of $\pm 50\%$ on the system *LCOEx*. Changing this parameter affects the *OPEX* of the system, so that the higher the share of *OPEX* in the *TOTEX*, the higher the impact of c_{fuel} . The greatest

range of $LCOEx$ was obtained for S10 (hydrogen), $\pm 35\%$ with respect to baseline, while S7 (methanol) showed the lowest variation, $\pm 22\%$ with respect to baseline. S9 (ammonia) remained the most competitive system, although for very high c_{fuel} , S7 (methanol) became more interesting. Figure 5 (b) represents the sensitivity to the annual interest rate i , which was also varied within $\pm 50\%$. Modifying this parameter mainly affects the system $CAPEX$ through the CRF . The greatest impacts were observed for systems with higher shares of $CAPEX$ in their $TOTEX$. Indeed, S7 (methanol) presented the highest variations of $\pm 16\%$, while S10 (hydrogen) ranged between $\pm 8\%$. It is interesting to note that for low i values, methanol became competitive with ammonia. Figure 5 (c) shows the influence of varying the stack lifetime n_{yr_stack} from 3 to 15 years on the system $LCOEx$. As observed for the i , the impact of n_{yr_stack} is also marked by the share of $CAPEX$ (particularly, the stack replacement cost) in $TOTEX$. The greatest effect was obtained for S7 (methanol), with $LCOEx$ between -21% and 28% with respect to baseline, while S10 (hydrogen) is the least impacted one, with $LCOEx$ between -12% and 16% with respect to baseline. Doubling the n_{yr_stack} from 5 to 10 years for S7 (methanol) would reduce $LCOEx$ by 14% .

Conclusions

A detailed cost assessment was performed for 100 kW_e SOFC modules driven by methane, methanol, diesel, ammonia, and hydrogen. The SOFC module was composed of an SOFC stack and BoP components (e.g. blower, reformer, heat exchangers, after burner, pumps). Cost functions were collected from the literature to determine equipment purchase cost. The total annual cost (composed of $CAPEX$ and $OPEX$) and the $LCOEx$ were used to evaluate and compare the systems, including the total annual cost. In this regard, the $LCOEx$ was selected as it accounts for energy products having different qualities (e.g. electricity, and thermal energy at different temperature levels). Sensitivity analyses were performed to evaluate the impact of key parameters on the results.

Implementing COGR had a positive impact on the cost of the system. The higher cost of installing the COGR blower was compensated by investment and operation cost reductions. The lowest $LCOEx$ were found for ammonia with COGR, 0.260 EUR/kWh , and methanol with COGR, 0.270 EUR/kWh , while hydrogen had the highest $LCOEx$, 0.430 EUR/kWh . When only investment costs were considered, ammonia- and hydrogen-fueled systems had the lowest specific investment costs, about 1145 EUR/kW_e and 1183 EUR/kW_e , respectively. It is worth noting that the SOFC stack was always the component with the highest share in the $CAPEX$ of the system. The sensitivity analyses suggested that the fuel purchase cost, stack lifetime, and annual interest rate could have important impacts on the system cost, depending on the share of $CAPEX$ and $OPEX$ in the $TOTEX$ of the system. Overall, the most promising fuels were ammonia and methanol.

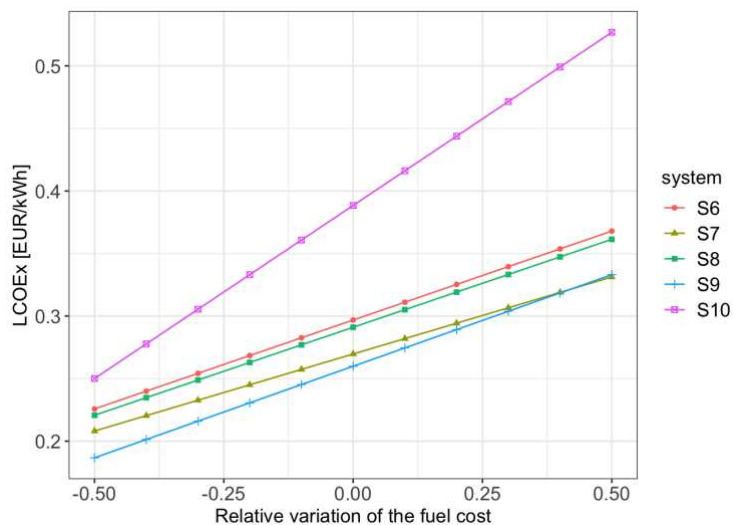

(a) Sensitivity to fuel purchase price

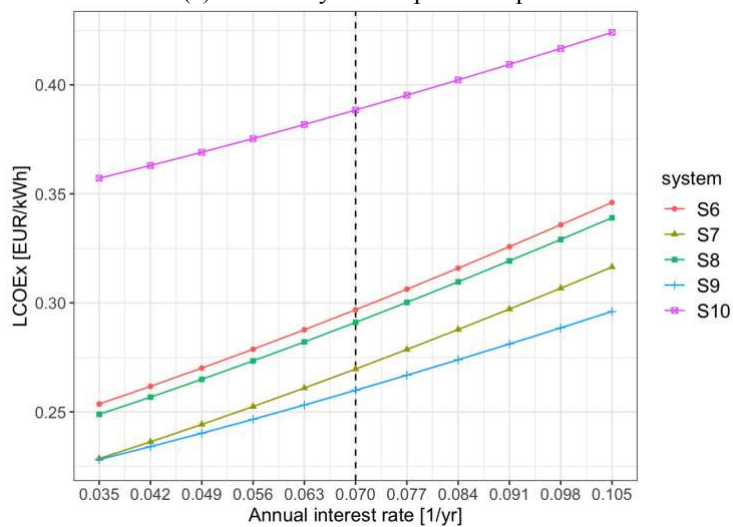

(b) Sensitivity to annual interest rate

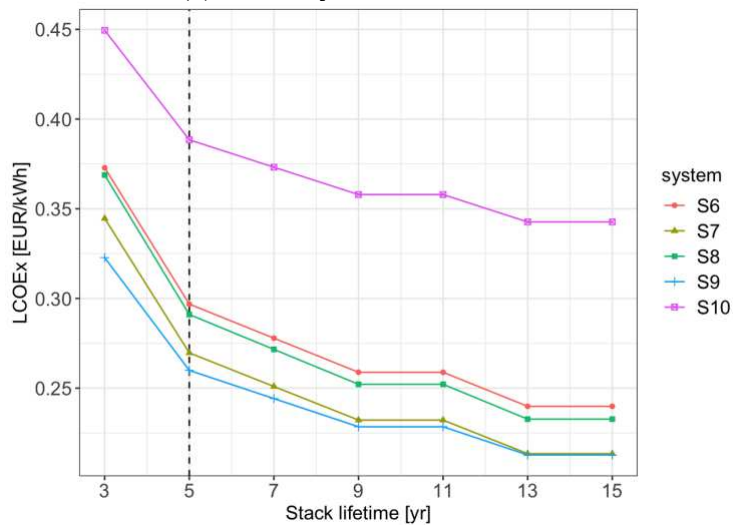

(c) Sensitivity to stack lifetime

Figure 5. Sensitivity analyses of key parameters.

Acknowledgments

This research result is part of a NAUTILUS project that has received funding from the European Union's Horizon 2020 research and innovation programme under grant agreement No 861647. The Nautilus Project aims at developing, evaluating and validating a highly efficient and dynamic integrated SOFC fuelled by LNG for long-haul passenger ships. The authors declare that they have no known competing financial interests or personal relationships that could have appeared to influence the work reported in this paper. The first author acknowledges the funding received from the Ministry of Science, Innovation and Universities of Spain and the European Union "Next Generation EU" under the Margarita Salas Grant.

References

1. IMO. *Fourth IMO GHG Study*. (2020).
2. IMO. *Sulphur oxides (SOx) – Regulation 14*. (2020).
3. IMO. *Nitrogen oxides (NOx) – Regulation 13*. (2020).
4. F. Baldi, S. Moret, K. Tammi, and F. Maréchal, The role of solid oxide fuel cells in future ship energy systems. *Energy*, **194**, 116811 (2020).
5. B.N. van Veldhuizen, L. van Biert, K. Visser, and H. Hopman, Comparative Analysis of Alternative Fuels for Marine SOFC Systems, *PRADS*, 1240–1258 (2022).
6. L. Kistner, F. L. Schubert, C. Minke, A. Bensmann, and R. Hanke-Rauschenbach, Techno-economic and Environmental Comparison of Internal Combustion Engines and Solid Oxide Fuel Cells for Ship Applications, *Journal of Power Sources*, **508**, 230328 (2021).
7. M. Rivarolo, D. Rattazzi, L. Magistri, and A. F. Massardo, Multi-criteria comparison of power generation and fuel storage solutions for maritime application, *Energy Conversion and Management*, **244**, 114506 (2021).
8. A.D. Korberg, S. Brynolf, M. Grahn, I. R. Skov. Techno-economic assessment of advanced fuels and propulsion systems in future fossil-free ships. *Renewable and Sustainable Energy Reviews*, **142**, 110861, (2021).
9. B. N. van Veldhuizen, L. van Biert, A. Amladi, T. Woudstra, K. Visser, and P. V. Aravind, The effects of fuel type and cathode off-gas recirculation on combined heat and power generation of marine SOFC systems, *Energy Conversion and Management*, **276**, 116498 (2023).
10. J. Kersey, N.D. Popovich, A.A. Phadke, Rapid battery cost declines accelerate the prospects of all-electric interregional container shipping. *Nature Energy*, **7**, 664–74, (2022).
11. Battelle Memorial Institute. Manufacturing Cost Analysis of 100 and 250 kW Fuel Cell Systems for Primary Power and Combined Heat and Power Applications. (2016).
12. R. Turton, J.A. Shaeiwitz, D. Bhattacharyya, W.B. Whiting. Analysis, Synthesis, and Design of Chemical Processes. *Prentice Hall*, (2018).
13. ECB. *Euro foreign exchange reference rates* [Internet]. (2023). Available from: https://www.ecb.europa.eu/stats/policy_and_exchange_rates/euro_reference_exchange_rates/html/index.en.html.
14. W. Ligang, Y. Hangyu. Flow-sheet layout initial version. *WASTE2WATTS*, (2022).

15. W. Ligang. Converting WASTE to offer flexible GRID balancing Services with highly-integrated, efficient solid-oxide plants. *WASTE2GRIDS*, (2019).
16. J. Cren. D3.5 PtG/PtL components cost estimate. *ECo - Efficient Co-Electrolyser for Efficient Renewable Energy Storage*, (2019).
17. Ship & Bunker. *Rotterdam Bunker Prices* [Internet]. (2023). Available from: <https://shipandbunker.com/prices/emea/nwe/nl-rtm-rotterdam>.
18. Trading Economics. *Natural gas* [Internet]. (2023). Available from: <https://tradingeconomics.com/commodity/natural-gas>.
19. K.H.R. Rouwenhorst, G. Castellanos. Innovation Outlook: Renewable Ammonia. *IRENA*, (2022).
20. M. Ji, J. Wang. Review and comparison of various hydrogen production methods based on costs and life cycle impact assessment indicators. *International Journal of Hydrogen Energy*, **46**, 38612–35, (2021).
21. M.A. Lozano, L.S. Serra, E.A. Pina. Optimal design of trigeneration systems for buildings considering cooperative game theory for allocating production cost to energy services. *Energy*, **261**, 125299, (2022).