

## **Bromate removal in an ozone - granular activated carbon filtration process for organic micropollutants removal from wastewater**

van der Hoek, Jan Peter; Deng, Tianyi; Spit, Tiza; Luimstra, Veerle; de Kreuk, Merle; van Halem, Doris

**DOI**

[10.1016/j.jwpe.2024.104877](https://doi.org/10.1016/j.jwpe.2024.104877)

**Publication date**

2024

**Document Version**

Final published version

**Published in**

Journal of Water Process Engineering

**Citation (APA)**

van der Hoek, J. P., Deng, T., Spit, T., Luimstra, V., de Kreuk, M., & van Halem, D. (2024). Bromate removal in an ozone - granular activated carbon filtration process for organic micropollutants removal from wastewater. *Journal of Water Process Engineering*, 58, Article 104877.  
<https://doi.org/10.1016/j.jwpe.2024.104877>

**Important note**

To cite this publication, please use the final published version (if applicable).  
Please check the document version above.

**Copyright**

Other than for strictly personal use, it is not permitted to download, forward or distribute the text or part of it, without the consent of the author(s) and/or copyright holder(s), unless the work is under an open content license such as Creative Commons.

**Takedown policy**

Please contact us and provide details if you believe this document breaches copyrights.  
We will remove access to the work immediately and investigate your claim.



## Bromate removal in an ozone - granular activated carbon filtration process for organic micropollutants removal from wastewater

Jan Peter van der Hoek<sup>a,b,\*</sup>, Tianyi Deng<sup>a,c,1</sup>, Tiza Spit<sup>c</sup>, Veerle Luimstra<sup>c</sup>, Merle de Kreuk<sup>a</sup>, Doris van Halem<sup>a</sup>

<sup>a</sup> Delft University of Technology, Department of Water Management, Stevinweg 1, 2628CN Delft, the Netherlands

<sup>b</sup> Waternet, Korte Ouderkerkerdijk 7, 1096AC Amsterdam, the Netherlands

<sup>c</sup> Witteveen+Bos, Leeuwenbrug 8, 7411TJ Deventer, the Netherlands

### ARTICLE INFO

Editor: H.H. Ngo

#### Keywords:

Bromate  
Denitrification  
Nitrate  
Organic micropollutants  
Ozone – granular activated carbon filtration

### ABSTRACT

Organic micropollutants (OMPs) enter the aquatic environment via municipal wastewater treatment plants (WWTPs). As conventional WWTPs have limited capacity for the removal of OMPs, additional processes are required, like ozone - granular activated carbon (GAC) filtration. A specific lay-out of this process is the O3-STEP® process, in which the removal of suspended solids, OMPs, phosphate and nitrate is combined. However, ozonation may result in formation of bromate, a compound with a strict water quality standard of 1 µg/L for surface waters in The Netherlands. This limits the applicability of ozonation in wastewater treatment. This study examined biological bromate removal associated with denitrification processes in the GAC filter of the O3-STEP® process. In this GAC filter methanol is dosed for nitrate removal by biological denitrification. In column experiments, bromate and nitrate were removed simultaneously under both anoxic and oxic conditions. Depletion of oxygen within the biofilm surrounding the GAC granules most probably is the reason for denitrification under oxic bulk conditions, although aerobic denitrification cannot be excluded. In batch experiments, the presence of nitrate did not affect bromate removal, whereas the presence of dissolved oxygen had a slight inhibitory effect on bromate removal and nitrate removal. Addition of methanol increased both nitrate and bromate removal, which is hypothesized to occur through an increased availability of electron donors in the water. The results show that a denitrifying GAC filter in the ozone - GAC filtration process mitigates the bromate formation, which broadens the applicability of this process for OMP removal from wastewater.

### 1. Introduction

In the past years the presence of organic micropollutants (OMPs) in the aquatic environment, such as pesticides, pharmaceuticals, and personal care products, has received a lot of attention [1–3]. It has been shown that the presence of these compounds can have negative effects on the aquatic environment and human health [4,5]. Many of these OMPs enter the aquatic environment via municipal wastewater treatment plants (WWTPs) [6], as traditional WWTPs are not specifically designed for the removal of OMPs [7]. The average removal efficiency of OMPs in WWTPs ranges from 30 % to 65 % [8]. Therefore, many investigations into OMP removal technologies for wastewater treatment, including adsorption [9,10], filtration [11], membrane processes [12], advanced oxidation [13–15], biodegradation [11,16] and combined

processes [12,17,18] have been carried out. Full-scale application for OMP removal is already in place in several WWTPs [19,20]. In addition, in the recast of the European Urban Wastewater Treatment Directive a removal standard of 80 % will be introduced for these compounds in WWTP effluent, further necessitating the introduction of quaternary treatment.

An attractive combined process is ozonation followed by granular activated carbon (GAC) filtration. Some OMPs are removed more effectively by ozone while others are better removed by activated carbon [21]. As such, combining the two methods broadens the range of substances that can be removed. Reungot et al. [9] concluded that the main ozonation followed by activated carbon adsorption in a full-scale reclamation plant treating secondary treated wastewater played a key role in decreasing the concentration of many organic micropollutants to

\* Corresponding author at: Delft University of Technology, Department of Water Management, Stevinweg 1, 2628CN Delft, the Netherlands.

E-mail address: [j.p.vanderhoek@tudelft.nl](mailto:j.p.vanderhoek@tudelft.nl) (J.P. van der Hoek).

<sup>1</sup> Shared first authorship.

below the level of detection. The ozonation step resulted in a decreased micropollutant concentration to <20 % of the influent concentration for caffeine, carbamazepine, codeine, diclofenac, doxylamine, erythromycin, frusemide, gemfibrozil, hydrochlorothiazide, metoprolol, paracetamol, ranitidine, roxithromycin, sulphamethoxazole, tramadol, trimethoprim and venlafaxine. The subsequent GAC filtration further decreased the compound concentrations to levels below the level of quantification except for gabapentin and roxithromycin. However, an important concern with ozonation is the formation of bromate which is considered a human carcinogen [22]. Enhanced treatment of wastewater by ozone may result in the formation of bromate, depending on water quality parameters such as bromide and DOC (Dissolved Organic Carbon) concentrations, and process settings such as contact time and ozone dose, expressed as g O<sub>3</sub>/g DOC [23]. In The Netherlands, the standard for bromate in surface waters is 1 µg/L [24,25], which may limit the application of ozone or the combination of ozone with GAC filtration. At high bromate concentrations in the treated wastewater effluent, discharge into the surface water may result in exceedance of this standard.

However, bromate may be removed biologically, a phenomenon that has already been recognized in drinking water treatment. Hijnen et al. [26,27] studied the removal of bromate in a denitrifying bioreactor supplemented with methanol, used for nitrate removal from drinking water. They concluded that bromate was reduced to bromide by a mixed bacterial population. Nitrate was the preferred electron acceptor for the bromate reducing bacteria, and bromate reduction only occurred when nitrate was almost completely removed. Wang et al. [28] studied the removal of bromate as a by-product of ozonation in subsequent managed aquifer recharge systems, specifically in anoxic nitrate-reducing zones. A drastic increase in bromate degradation was observed in the sudden absence of nitrate in both batch reactors and columns, indicating that bromate and nitrate competed for biodegradation by denitrifying bacteria. Nitrate was preferred as an electron acceptor under the simultaneous presence of nitrate and bromate. However, within 75 days' absence of nitrate in an anoxic column, bromate removal gradually decreased, indicating that the presence of nitrate is a precondition for denitrifying bacteria to reduce bromate in nitrate-reducing anoxic zones. Hübner et al. [29] studied the removal of DOC and assessed formation and stability of the by-product bromate in combined ozonation and managed aquifer recharge systems. During oxic infiltration, no significant bromate removal could be observed. However, under anoxic conditions, the bromate concentration was efficiently reduced. Additional biodegradation tests in small-scale columns indicated a simultaneous consumption of nitrate and bromate which functioned as electron acceptors.

In the application of combined ozonation - granular activated carbon filtration for the removal of OMPs from wastewater effluent, the O3-STEP® process is a specific system that combines the removal of suspended solids, nutrients and OMPs [30]. GAC filtration removes suspended solids, the combination of ozone and GAC filtration removes OMPs, phosphate is removed by inline coagulation and filtration in the GAC filter, and nitrate is removed by biological denitrification through methanol dosing to the GAC filter. During the ozonation bromate formation is possible, but the presence of a denitrifying GAC filter after the ozonation may have a positive effect on the bromate removal. Although GAC has been studied to determine its feasibility for bromate removal by adsorption, the presence of moderate to high levels of DOC, as is the case in wastewater treatment, resulted in poor bromate removal because of the competition for GAC's adsorptive sites [31]. Also Kirisits et al. [32] concluded that the presence of natural organic matter (NOM) and other anions were responsible for reducing the efficacy of GAC for bromate removal. As mentioned above, in drinking water treatment the removal of bromate under denitrifying conditions has been shown [26–28]. Hence, bromate may also be removed in biologically active filters used in wastewater treatment. Jahan et al. [33] concluded that microbial ecology developed in a biologically activated carbon (BAC) filtration

and presence of DOC might play a significant role in bromate reduction. The denitrifying GAC filter in the O3-STEP® process can be considered a form of BAC filtration. Lee et al. [34] tested the biological bromate mitigation after ozonation in enhanced wastewater treatment and found that the produced bromate at 0.3, 0.5 and 0.7 g O<sub>3</sub>/g DOC decreased by 8–21 % by biodegradation. Chuang and Mitch [35] showed >90 % removal of bromate by post-BAC treatment during wastewater effluent ozonation. Kirisits et al. [36] also observed bromate removal in a biologically active carbon filter, but showed that bromate removal decreased as the influent nitrate concentration was increased from 0.3 to 42.3 mg/L. With a 26-min EBCT bromate removal dropped from 86 % to 49 %, while with a 51-min EBCT it decreased from 95 % to 79 % only. Unfortunately, the redox conditions in the biologically active carbon filters were not specified in these studies which makes it difficult to understand the removal mechanism. Jahan et al. [33] recommended further research into bromate reduction in biofilters to understand the influencing or mitigation methods to reduce bromate concentrations and to successfully apply bromate reduction in large-scale systems. Therefore, the aim of this study was to investigate whether the GAC filter in the O3-STEP® process can remove bromate formed during the preceding ozonation step, thereby increasing the applicability of this process in wastewater treatment plants. The focus was on biological bromate reduction in the GAC filter, especially its interconnection with the denitrification process. The main research questions were: 1) where do denitrification and bromate removal take place in the GAC filter; 2) does the presence of nitrate inhibit bromate removal; 3) does dissolved oxygen, present in the ozonated water, affect nitrate and bromate reduction; and 4) does the addition of methanol enhance bromate and nitrate removal? Bromate and nitrate removal were analysed in the GAC filter of a O3-STEP® process on pilot plant scale treating effluent of the Dutch WWTP Horstermeer. In addition, batch experiments were performed using GAC from this GAC filter to further study the relation between denitrification and bromate reduction, and how this was related to oxygen and organic carbon concentrations.

## 2. Materials and methods

### 2.1. O3-STEP® pilot plant

Fig. 1 shows the process set-up of the O3-STEP® pilot plant. The 1-STEP® filter is the GAC filter in the O3-STEP® process. The feed water of the pilot plant was treated wastewater from the WWTP Horstermeer (capacity 150,000 p.e.), The Netherlands, consisting of a primary settling, biological treatment and secondary settling.

Table 1 shows the composition of the effluent from the secondary clarifier, which was the feed water of the O3-STEP® pilot plant.

Column experiments were performed using the GAC filter (1-STEP® filter) of the O3-STEP® pilot plant. Fig. 2 shows this GAC filter. The filter unit had a height of 4 m and a diameter of 0.52 m. Norit GAC 612 WFD was used as GAC, with a grain size of 1.70–3.35 mm. The GAC bed height was 2 m, and a supernatant of 1.1 m was maintained. By using a control valve in the effluent pipe a constant flow rate of 3 m<sup>3</sup>/h was maintained. The filter was operated in downflow mode. The filter was backwashed upflow every 260 min using water from the filtrate buffer tank. A more intensive backwash was done once every three backwashes where both air and water were flushed from the bottom of the filter. Substantial filter bed expansion was observed during backwashing. Sampling ports were present in the supernatant (SNT), in the GAC filter bed (FB1–FB4) and in the filter outlet (Outlet). Water samples were also taken at the filter inlet. Water samples from the inlet and all sampling ports were analysed for DO, NO<sub>3</sub><sup>-</sup>, NO<sub>2</sub><sup>-</sup> and BrO<sub>3</sub><sup>-</sup> to create concentration profiles over the filter height. Preceding these sampling campaigns, the effluent of the ozonation and the effluent of the GAC filter of the O3-STEP® was analysed for BrO<sub>3</sub><sup>-</sup> over a period of 11 months at an ozone dose of 0.4 g O<sub>3</sub>/g DOC.

Table 2 summarizes the process conditions of the O3-STEP® pilot

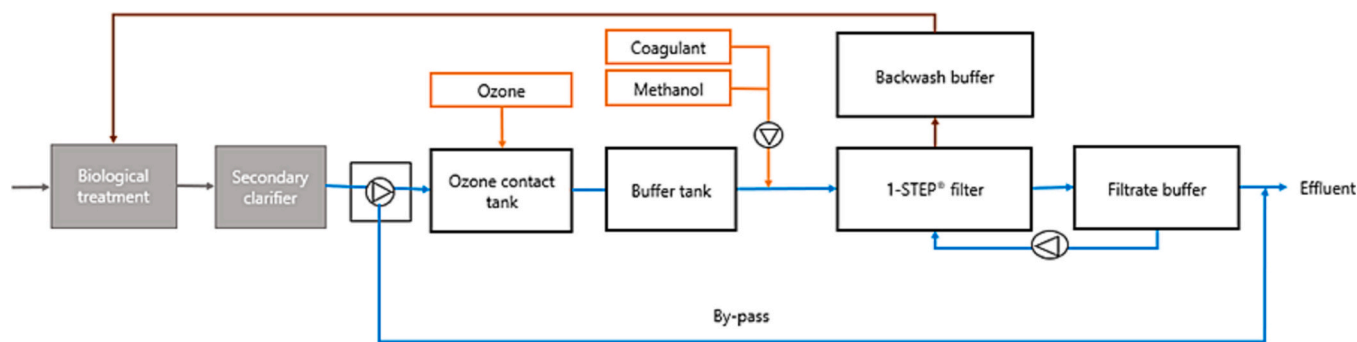

Fig. 1. Process scheme of the O3-STEP® pilot plant at WWTP Horstermeer. Treated wastewater from the full scale WWTP (biological treatment – secondary clarifier) was used as influent for the ozonation – GAC filtration pilot plant.

Table 1

Water quality of the effluent of the secondary clarifier of WWTP Horstermeer, which served as the influent of the O3-STEP® pilot plant. Data shown concern the experimental period July 2021–September 2022.

Parameter	Concentration in influent O3-STEP® pilot plant (average ± standard deviation)
COD <sup>a</sup> (mg/L)	29.5 ± 6.1
N-total (mg/L)	6.0 ± 2.0
NO <sub>3</sub> -N (mg/L)	2.9 ± 0.9
NO <sub>2</sub> -N (mg/L)	0.3 ± 0.3
P-total (mg/L)	0.3 ± 0.2
PO <sub>4</sub> -P (mg/L)	0.1 ± 0.04
DOC <sup>b</sup> (mg/L)	8.3 ± 1.7

<sup>a</sup> Chemical oxygen demand

<sup>b</sup> Dissolved organic carbon.

Table 2

Process conditions of the O3-STEP® pilot plant during the sampling campaigns to obtain DO, NO<sub>3</sub><sup>-</sup>, NO<sub>2</sub><sup>-</sup> and BrO<sub>3</sub><sup>-</sup> to create concentration profiles over the filter height.

Parameter	Value
Ozonation	
Ozone dose (mg O <sub>3</sub> /L)	5.5–12.1
Relative ozone dose (g O <sub>3</sub> /g DOC)	1.1
Ozone contact time (min)	25
GAC filtration	
Coagulant dose (mg/L)	0
Methanol dose (mg/L)	20–25
Relative methanol dose	1.2 kg COD/kg O <sub>2</sub> and 4.1 kg COD/kg NO <sub>3</sub> -N
Flow rate (m <sup>3</sup> /h)	3
Filtration rate (m/h)	13.8
Empty Bed Contact Time (min)	17.4
Backwash flow rate (m <sup>3</sup> /h)	11.3
Backwash duration water (sec)	400
Backwash duration air (sec)	120

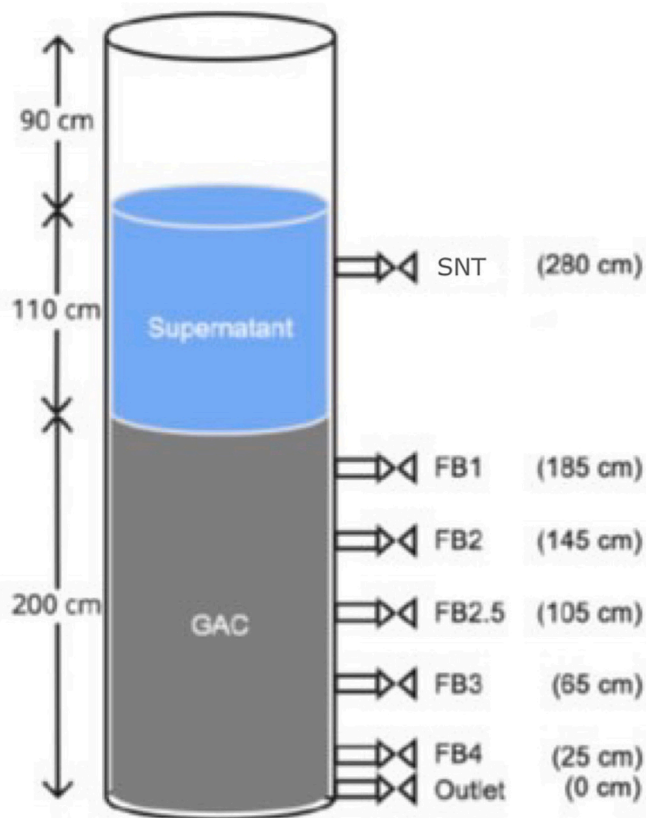

Fig. 2. The GAC filter (1-STEP® filter) in the O3-STEP® pilot plant at WWTP Horstermeer.

plant during the sampling campaigns to obtain the profiles. The ozone dose was set at 1.1 g O<sub>3</sub>/g DOC. With a DOC concentration in the influent of the O3-STEP® pilot plant between 5 and 11 mg/L (average 8.3 mg/L) the absolute ozone dose varied between 5.5 and 12.1 mg/L (average 9.1 mg/L). During the experiments a relatively high ozone dose of 1.1 g O<sub>3</sub>/g DOC was applied to enhance the formation of bromate. This is higher than the normally applied dose of 0.4 g O<sub>3</sub>/g DOC in the pilot plant [37]. Methanol was dosed for oxygen consumption of the oversaturated water after ozonation and as carbon source for the heterotrophic denitrifying bacteria in the GAC filter, based on 1.2 kg COD/kg O<sub>2</sub> and 4.1 kg COD/kg NO<sub>3</sub>-N. The absolute methanol dose varied between 20 and 25 mg/L. During the experimental period no coagulant was dosed due to the low phosphate level in the WWTP effluent. 1 mg/L bromide was dosed to the influent of the O3-STEP® pilot plant to increase bromate formation for experimental purposes.

2.2. Batch experiments

Four series of batch experiments (A, B, C and D) were conducted,

Table 3

Configuration of batch experiments.

Batch series	GAC dosage (g/L)	NO <sub>3</sub> <sup>-</sup> dosage (mg/L)	BrO <sub>3</sub> <sup>-</sup> dosage (µg/L)	Dissolved oxygen (mg/L)	Water source
A	120	12	100	<0.5	FB4
B	200	0	100	<0.5	FB4
C	120	9	100	>8	FB4
D	120	9	100	>8	FB1

summarized in Table 3. All batch experiments were performed in 2 L and 4 L bottles at room temperature (22–25 °C). For all batch experiments, GAC was collected from the top 50 cm of the filter bed of the GAC filter of the O3-STEP® pilot plant at WWTP Horstermeer using a scoop sampler, and transferred to the laboratory. To enhance mixing conditions, all batches were stirred on a shaker at 150 rpm. All batches were spiked with 100 µg/L bromate. All batch experiments were conducted in duplicate.

In batch experiments A and B the influence of the presence of nitrate on bromate removal under low DO (dissolved oxygen) concentrations was examined. In batch A, nitrate was spiked (12 mg/L) while in batch B no nitrate was spiked. Water was taken from sampling port FB4 of the GAC filter (bottom of the filter, see Fig. 2, water with a low DO). The average COD concentration of water samples taken from FB4 was 25 mg O<sub>2</sub>/L. The DO was further decreased to ≤0.5 mg/L by sparging nitrogen gas and sealing the bottles with caps and rubber stoppers to prevent any gas transfer between the bottles and atmosphere. The batches were sampled every hour for 8 h.

In batch C the influence of high DO concentrations on nitrate removal and bromate removal was examined. 9 mg/L nitrate was spiked to this series. As this batch was compared with batch A, also for batch C water was taken from FB4 (bottom of the filter). The DO concentration was kept above 8 mg/L by using aeration stones. The batches were sampled every 15 min for a period of 2 h.

In batch D, the influence of methanol on nitrate and bromate removal under oxic conditions was examined. Water was taken from sampling port FB1 of the GAC filter (top of the filter). The average COD level of water samples taken from FB1 was 70 mg O<sub>2</sub>/L. The higher methanol concentration in this water from sampling port FB1 accounted for the higher COD concentration in sampling port FB1 compared to sampling port FB4. The aeration method was the same as in series C and the DO concentration was kept above 8 mg/L. The batches were sampled every hour for 8 h.

Because batch series A, C and D were spiked with nitrate, less GAC containing biomass was used as compared to batch series B (no nitrate spiking), 120 g/L and 200 g/L respectively. In a preliminary experiment nitrate spiking in combination with a GAC dosage of 200 g/L showed too rapid nitrate consumption in the time span of 8 h.

Water samples from the batches were analysed for Br<sup>-</sup>, NO<sub>3</sub><sup>-</sup>, NO<sub>2</sub><sup>-</sup> and COD concentrations. The bromide concentration was used in the batch experiments as the indicator for bromate reduction. Previous studies suggest that bromide can be produced by bacteria almost stoichiometrically from bromate reduction [31,38]. To verify this hypothesis, bromate concentrations were measured for series A. This analysis showed that increased bromide concentrations accounted for 77 % of the decreased bromate concentrations, as can be seen in Table S2.1 (Supplemental Information 2). Either there may have been some bromate adsorption on the GAC, or intermediate products may have been formed during biological bromate reduction, such as BrO<sub>2</sub><sup>-</sup> [27]. However, bromate adsorption is very unlikely as the GAC filter was already in operation for one year at the time of this research, without reactivation. Huang et al. [39] reported that already after an operational period of 9 months no bromate removal was observed in a GAC filter. Thus, most likely the increase in bromide concentration resulted from biological bromate reduction and hence bromide was used as indicator for biological bromate reduction.

### 2.3. Chemicals

Sodium bromate (NaBrO<sub>3</sub>) and potassium nitrate (KNO<sub>3</sub>) reagents were used to prepare the spiking solutions. Both were purchased from Sigma Aldrich (St. Louis, MO, United States) and were of analytical grade. The spike solutions were prepared using ultrapure water produced by a Mill-Q Gradient water purification system (18 MΩ·cm, Veolia). Pure nitrogen gas was used for flushing the wastewater to reduce the DO level to ≤0.1 mg/L.

### 2.4. Analytical methods

DO measurements were conducted in aqueous phases and were analysed onsite or directly from the samples taken from the batches with a multimeter (Multi 340i WTW, Germany). DO in the filter column was measured in a way that prevented the aeration created by the water flow from the sampling port to the containers. The DO probe was placed diagonally in a beaker and measured continuously for 10 min while the water was flowing through the beaker. Values were recorded after 10 min. The bromate concentration was analysed by Het Waterlaboratorium (Haarlem, The Netherlands) using ion chromatography (IC), following the procedure described by NEN-EN-ISO 11206. The detection limit was 0.2 µg/L. COD concentrations were analysed using a HACH Lange DR3900 spectrophotometer using HACH kits. Nitrate, nitrite and bromide concentrations were analysed using a Profic 15 - AnCat ion chromatography (Metrohm 881 anion suppressed system) (Metrohm, Switzerland) in the Waterlab of the faculty of Civil Engineering and Geosciences, Delft University of Technology. The A Supp 150/4.0 anion column was used for the anion measurement with 3.2 mM Na<sub>2</sub>CO<sub>3</sub> and 1 mM NaHCO<sub>3</sub> eluent (runs at 0.7 mL/min). The suppressor was fed with 50 mM H<sub>2</sub>SO<sub>4</sub> reagent. A 100 µL sample loop was used. All samples analysed with the IC were filtered through 0.45 µm filters (Whatman, Germany) before analysis. The conductivity data were translated to concentration using the MagIC Net software.

## 3. Results

### 3.1. Nitrate and bromate removal in the GAC filter

Fig. 3 shows the bromate concentrations after ozonation at an ozone dose of 0.4 g O<sub>3</sub>/g DOC and after the GAC filtration, over a period of 11 months. In this period, the GAC filter was operated under denitrifying conditions and similar redox conditions as during the subsequent sampling campaigns to create DO, NO<sub>3</sub><sup>-</sup>, NO<sub>2</sub><sup>-</sup> and BrO<sub>3</sub><sup>-</sup> profiles over the filter height. A clear decrease in bromate was observed. Based on this decrease, two sampling campaigns were performed at an elevated ozone dose of 1.1 g O<sub>3</sub>/g DOC. The elevated ozone dose was applied to enhance bromate formation during ozonation.

To assess the removal of nitrate and bromate in the GAC filter bed, concentration profiles were measured along a gradient. Concentration profiles over the GAC filter bed height were measured 30 min before backwashing (PreBW) and 20 min after backwashing (PostBW). Fig. 4(I, II, III) shows the profiles of DO, nitrite and nitrate. Oxygen concentrations in the influent and in the supernatant water were very high, up to

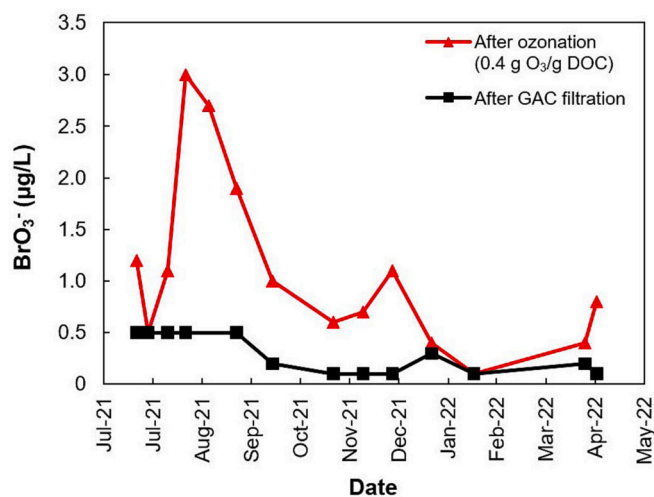

Fig. 3. Bromate concentrations after ozonation and after GAC filtration in the O3-STEP® pilot plant at an ozone dose of 0.4 g O<sub>3</sub>/g DOC.

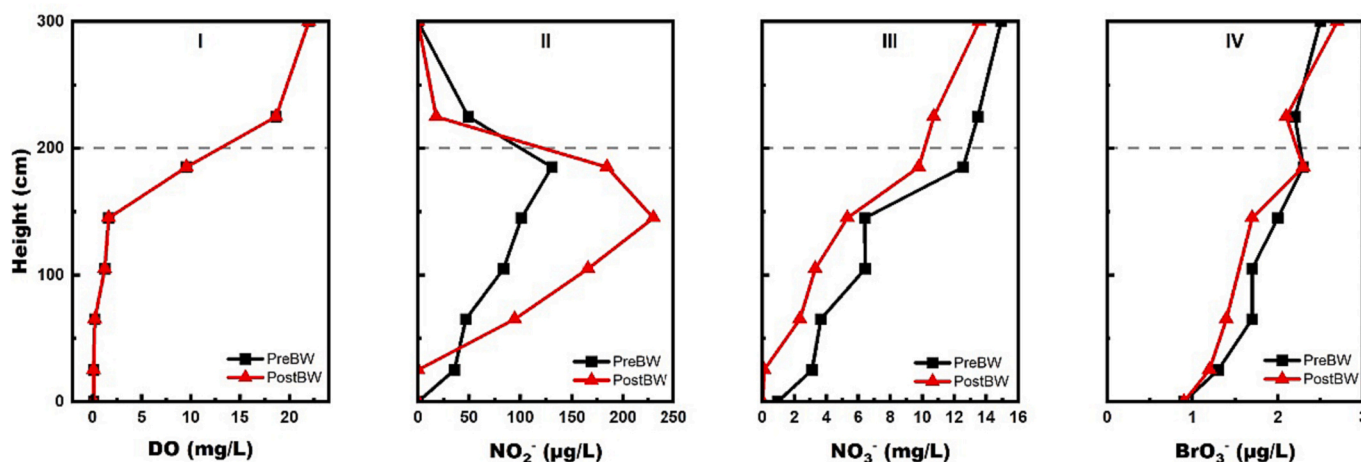

Fig. 4. Concentration profiles over the height of the GAC filter of the O3-STEP® pilot plant at WWTP Horstermeer: (I) DO; (II) nitrite; (III) nitrate and (IV) bromate profiles before (PreBW) and after (PostBW) a backwash. The grey dash lines represent the height of the top surface of the GAC filter bed. Above this line is the supernatant water and below this line the GAC filter bed.

22 mg/L due to the preceding ozonation. Two sections could be distinguished in the filter bed: an oxic zone from 145 cm to 200 cm where oxygen decreased from relatively high concentrations to 1.65 mg/L, and an anoxic zone from 0 to 145 cm. The supernatant from 200 to 300 cm also contained high oxygen concentrations, although DO did decrease in the supernatant, probably due to biological activity. Nitrate concentrations also decreased in the supernatant, as well as in the oxic zone despite the presence of oxygen. 59 % of the influent nitrate was removed in the supernatant and the oxic zone, while in the anoxic zone nitrate was further decreased to the detection limit. Nitrite, as intermediate product of denitrification, was formed up to a concentration of 235 µg/L and then decreases to 0 in the filter effluent.

Fig. 4(III, IV) shows the nitrate profiles and bromate profiles over the GAC filter bed before and after a backwash. When comparing the bromate profile with the nitrate profile, significant similarities in their trends were found. Like nitrate concentrations, bromate concentrations kept decreasing over the filter height, and an average of 65 % was removed in the GAC filter.

### 3.2. Bromate and nitrate removal in batch experiments

In batch experiments A and B the influence of the presence of nitrate

on bromate removal under low DO concentration was examined. Fig. 5 shows the nitrate removal and bromide formation as indicator for biological bromate removal in batch experiments A and B. In both the DO was below 0.5 mg/L. In batch A, both nitrate and bromate were present while in batch B only bromate was present.

Bromide formation profiles in batch experiments A and B were similar. In the absence of nitrate, bromide formation in the first 60 min in batch B was almost the same as in batch A, 22 µg/L (corrected for the higher GAC dosage in batch B (200 g/L instead of 120 g/L) by a factor 120/200) and 19 µg/L respectively. The maximum bromide formation after 300 min was also similar for batch experiments B and A, 31 µg/L (corrected for the higher GAC dosage in batch B) and 35 µg/L respectively. Thus, the presence of nitrate did not affect the bromide formation. A decrease in bromide concentrations was observed from the 5th to 7th hour in both batches.

In batch experiments A and C the influence of high DO concentrations on nitrate and bromate removal was examined. Fig. 6 shows the nitrate removal and bromide formation in batch experiments A (anoxic) and C (oxic at a DO >8 mg/L). In both batches nitrate and bromate were added. The bromide profiles in batch experiments A and C during the first 2 h were similar, but under anoxic conditions (A) bromide formation was 26 µg/L while under oxic conditions (C) bromide formation was

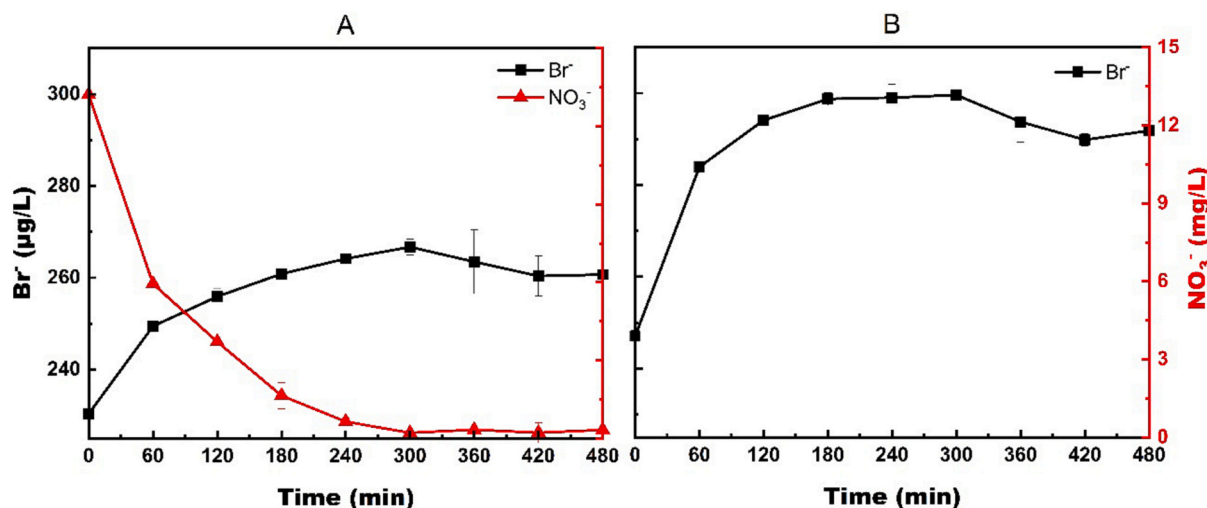

Fig. 5. Nitrate removal and bromide formation in batch experiments A and B at a DO concentration < 0.5 mg/L. Batch A was spiked with nitrate and bromate, batch B was spiked with only bromate.

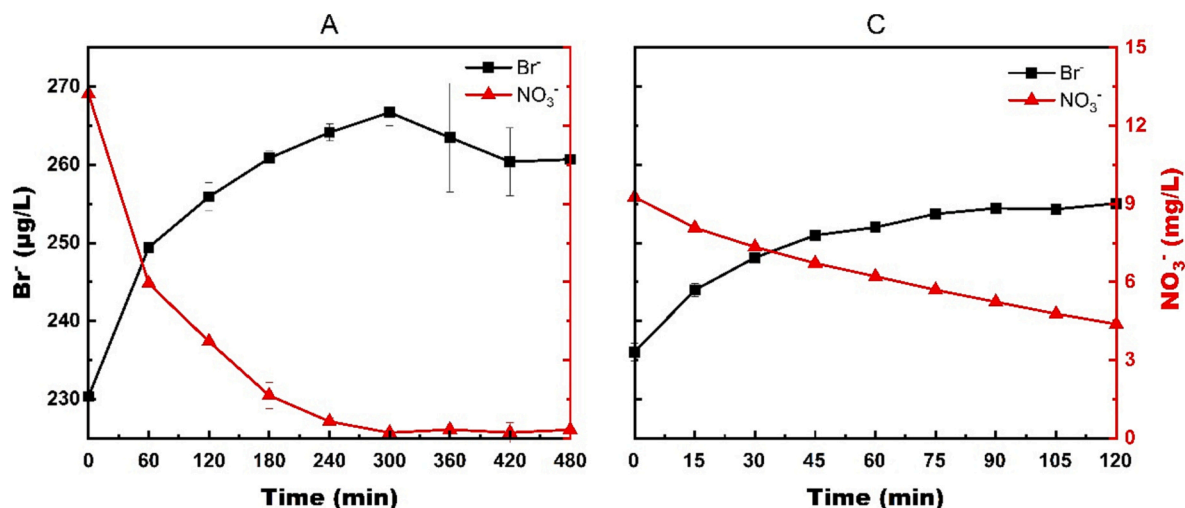

Fig. 6. Nitrate removal and bromide formation in batch experiments A and C. Both batches A and C were spiked with nitrate and bromate, batch A was anoxic (DO <0.5 mg/L), batch C was oxic (DO >8 mg/L).

slightly lower, 19 µg/L. Also, the nitrate removal under oxic conditions (C) appeared to be lower than under anoxic conditions (A) during the first 2 h, 4.9 mg/L and 9.5 mg/L respectively. Thus, anoxic conditions resulted in higher bromide formation and higher nitrate removal.

In batch experiments C and D the role of an additional carbon source on nitrate and bromate removal under oxic conditions was examined. Fig. 7 compares nitrate removal and bromide formation in batch experiments C and D. Both were operated under oxic conditions with a DO >8 mg/L, but in batch D methanol was added as additional carbon source.

In the presence of methanol bromide formation was higher in the first 2 h. In batch C (without methanol addition) bromide formation was 19 µg/L while in batch D (with methanol addition) it was 56 µg/L. Nitrate removal in the presence of methanol in the first 2 h was also higher: 4.9 mg/L without methanol addition (batch C) and 9.7 mg/L with methanol addition (batch D). Methanol addition both enhanced bromide formation and nitrate removal.

#### 4. Discussion

It is commonly accepted that denitrification predominantly occurs under anoxic conditions [40–42]. Previous studies on biological

bromate removal suggest a strong connection with the denitrification process [28,43–46]. In addition, many studies have demonstrated that bromate reduction occurs when the nitrate concentration is low [27,28,33]. The findings in this study were not all in agreement with these observations of other studies.

##### 4.1. Nitrate removal in the presence of oxygen

In contrast to previous research, the nitrate and DO profiles along a gradient of the GAC filter clearly indicate nitrate removal in the supernatant and in the oxic zone of the filter bed (top 145–200 cm), from 15 mg/L to 5.5 mg/L (Fig. 4). Nitrate concentrations further decreased to below the detection limit in the anoxic zone of the GAC filter (bottom 145 cm). A similar phenomenon was observed in batch experiments C and D (Figs. 6 and 7): in these experiments denitrification took place at a DO concentration > 8 mg/L when GAC from the top 50 cm of the GAC filter (the oxic zone) was incubated with water from the GAC filter spiked with nitrate. However, DO slightly inhibited denitrification and bromide formation. During the first 2 h, in batch C (oxic) nitrate removal was half of the nitrate removal in batch A (anoxic) and bromate formation in batch C was lower as in batch A, 19 µg/L and 26 µg/L respectively (Fig. 6). Almost complete removal of approximately 10 mg/

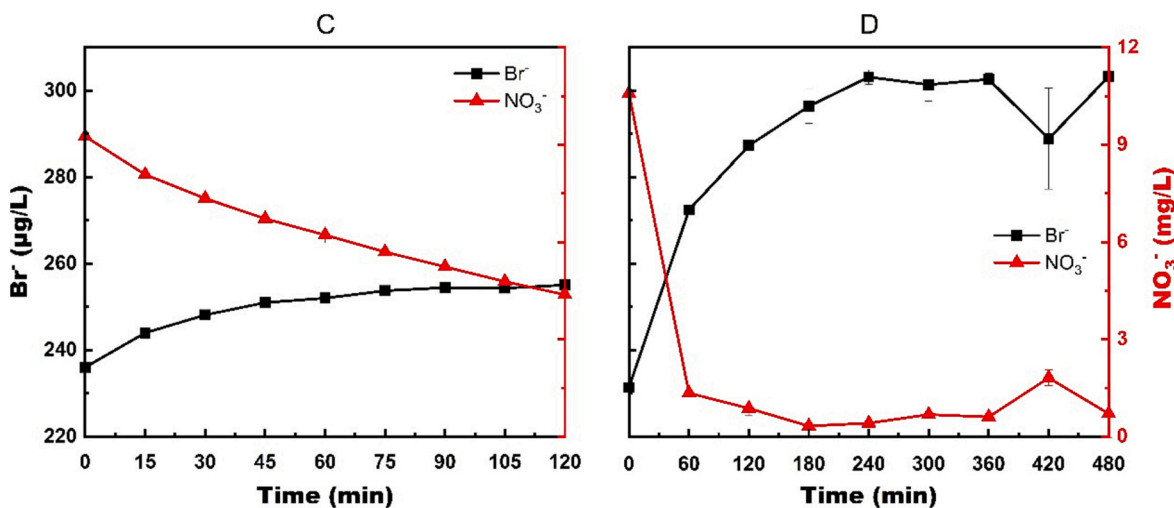

Fig. 7. Nitrate removal and bromide formation in batch experiments C and D. Both batches C and D contained nitrate and bromate and were oxic (DO >8 mg/L), in batch D methanol was added.

L nitrate was achieved in aerated water within 3 h in batch experiment D (Fig. 7). The additional methanol in batch D resulted in a twice as high nitrate removal in batch D compared to batch C during the first 2 h, and also a higher bromide formation, 56  $\mu\text{g/L}$  in batch D and 19  $\mu\text{g/L}$  in batch C. Five hypotheses may explain the nitrate removal under oxic conditions. Firstly, nitrate may have functioned as a nitrogen source for aerobic cell growth, particularly in the absence of ammonium [47]. In the GAC filter of the O3-STEP® pilot plant, a high methanol dosage is required to compensate for the high oxygen concentration following ozonation and to create anoxic conditions. Aerobic biomass uses methanol as carbon source and oxygen as electron acceptor. In the GAC filter, the rate of nitrate removal slowed down at a height of 150 cm, correlating with the deceleration of oxygen depletion. Given that aerobic bacterial growth typically exhibits higher rates compared to anaerobic growth, it is reasonable to consider that the higher nitrate consumption rate observed in the aerobic zone might have resulted from nitrogen serving as a nitrogen source for aerobic cell growth. However, the exclusive utilization of nitrate for aerobic cell growth in the filter's aerobic zone would necessitate an exceptionally high bacterial growth rate of 250 mg VSS/(L·h) (volatile suspended solids). Such a high growth rate conflicts with the actual bacterial growth rate observed in the filter (calculation included in the Supplemental Information 3). A second explanation may be that nitrate was adsorbed on the GAC. However, as with bromate, adsorption is very unlikely to occur, especially after a prolonged running time of the GAC filter [32,39]. Wang et al. [48] conducted a study using scanning electron microscope (SEM) photographs of virgin GAC surface and GAC surface after one and eight years of operation. The results revealed that only a few pores were discernible on the GAC surface after one and eight years of use. This suggests that biological conversion, rather than adsorption, played a dominant role in water quality purification after one year of operation. A third explanation for denitrification in the supernatant and in the oxic zone of the GAC filter, and in batch experiments C and D at a high DO level, may be depletion of oxygen within the biofilm that grows around the GAC granules. Fig. 8 shows a microscopic photograph of the cross-section of an activated carbon granule from the oxic zone of the GAC filter of the O3-STEP® pilot plant at WWTP Horstermeer. Possibly the outside layer of the biofilm creates an anoxic environment closer to the granule, that facilitates nitrate utilization by denitrifying bacteria. These granules were also used in the batch experiments. In accordance, this mechanism of oxygen depletion in biofilms has been observed in previous studies

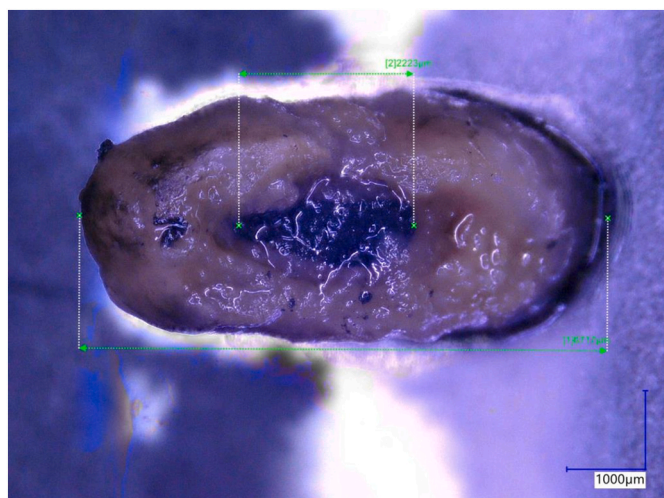

Fig. 8. Cross-section of a GAC granule in the oxic zone of the GAC filter. The black core of the granule is activated carbon with a diameter of appr. 2 mm. The pink-brownish layer surrounding the black core is the biofilm, with a thickness of appr. 2 mm. (For interpretation of the references to color in this figure legend, the reader is referred to the web version of this article.)

using GAC filters. For instance, Liang et al. [49] demonstrated denitrification in an immobilized microbial community at DO levels higher than 6 mg/L. Similarly, denitrification under aerobic conditions was observed in a draft tube spouted bed reactor with GAC dosage as supporting material for microbial growth [50]. Fig. S4.1 (Supplemental Information 4) shows that biomass was also present in the supernatant of the GAC filter as brown granules and on the filter wall, responsible for oxygen and nitrate consumption in this part of the GAC filter. Also here depletion of oxygen within the biofilm may have taken place. The higher nitrate removal and bromide formation in batch C (anoxic) compared to batch A (oxic) supports the anoxic removal as dominant mechanism. Also the higher nitrate removal and bromide formation in batch D (additional methanol) compared to batch C supports the anoxic removal as dominant mechanism: the additional methanol results in oxygen depletion and anoxic conditions deeper in the biofilm surrounding the GAC granules.

The fourth possible explanation for nitrate degradation under aerobic conditions is aerobic denitrification. Aerobic denitrification represents a specific group of bacteria capable of performing denitrification even in oxygen-rich conditions. This concept was first proposed by Robertson and Kuenen in 1984 [47]. Some aerobic denitrifying bacteria have been identified within the genus *Pseudomonas*, amongst which species capable of bromate reduction [51,52]. Studies have suggested that intermittent aeration is necessary to enrich aerobic denitrifying bacteria [47,51,53,54]. In the GAC filter described in this study, alternating oxic-anoxic conditions were present as the filter was backwashed every 260 min, and every three backwashes a more intensive backwash was applied by flushing both water and air from the bottom of the filter. However, consensus has not yet been reached on the mechanisms of aerobic denitrification [55]. A fifth explanation may be that denitrifying bacteria (and their active enzymes) were mixed through the entire filter during the frequent backwashing. However, there was a stratification in the GAC filter bed: on top large granules with a thick biofilm and relatively low density due to excessive biomass growth (oxygen consumption by aerobic heterotrophic bacteria, also visible in Fig. 4(I)), in the deeper layers carbon granules covered with much less biofilm and thus a higher density. The biofilm morphology and size of the granules from the oxic zone and anoxic zone are shown in the Supplemental Information S4 (Fig. S4.2). After backwashing still a stratification was present. Therefore, complete mixing after backwashing was not the case. Based on these considerations, the third explanation of oxygen depletion within the biofilm seems plausible for the denitrification under oxic conditions, but additional research is necessary to exclude aerobic denitrification.

## 4.2. Effect of water quality parameters on bromate reduction

### 4.2.1. Influence of nitrate on bromate reduction

Both in the GAC filter experiments (Fig. 4(IV)) and in the batch experiments (Figs. 5 and 6) bromate removal c.q. bromide formation took place in the presence of nitrate, while some studies showed that the absence of nitrate is required. The bromate removal measured in the GAC filter of the O3-STEP® pilot plant over an 11-months period (Fig. 3) suggests that the bromate removal is sustainable. With respect to the batch experiments, bromate removal c.q. bromide formation in the presence of nitrate was both the case for anoxic (Fig. 5) and oxic conditions (Fig. 6). In literature, the effect of nitrate on biological bromate reduction is not conclusive. In many studies of biological bromate reduction by denitrifying bacteria nitrate was found to inhibit bromate reduction [27,28,36]. In the batch experiments described in this study, in which only bromate was added, bromate removal was observed without the presence of nitrate. However, the experiments were performed with fresh biomass from the GAC filter, hence no conclusion can be drawn on the bromate removal capacity in the long-term absence of nitrate. Also related to a managed aquifer recharge system, Hübner et al. [29] studied the simultaneous consumption of nitrate and bromate in



anoxic columns. No effect of nitrate concentration on the removal of bromate was observed, both at high (22 mg/L) and low (4 mg/L) nitrate concentrations. In the GAC filter described in this study, the bromate reduction rate remained relatively constant, even as the nitrate concentration decreased (Fig. 4). In the batch experiments the bromide formation profiles were similar, and the bromide formation in the first 60 min in batch experiment A (where nitrate was present) was very similar to batch experiment B (where nitrate was not present): 19 µg/L and 22 µg bromide/L (corrected for the higher GAC dosage in batch B) respectively. In addition, the maximum bromide formation was very similar in batch experiments A and B, 35 µg/L and 31 µg/L (corrected for the higher GAC dosage in batch B) respectively. The similarity shows that the presence of nitrate did not seem to inhibit bromate reduction.

#### 4.2.2. Influence of DO on bromate reduction

In the GAC filter of the O3-STEP® pilot plant, the DO concentration did not seem to affect bromate removal. Bromate concentrations decreased both in the oxic zone (top 145–200 cm) and in the anoxic zone (bottom 0–145 cm), although the removal rate was slightly higher in the anoxic zone, especially for the pre-backwash profile (Fig. 4). In the batch experiments, the anoxic group (A) showed a bromide formation of 26 µg/L after the first 2 h while under oxic conditions (C) bromide formation was a lower, 19 µg/L. This may indicate a partial inhibitory effect of DO on bromate reduction. The literature indicates that bromate removal is possible in the presence of DO and also indicates the importance of the level of DO and the presence of a carbon source. For instance, Kirisits et al. [36] studied an aerobic BAC filter for drinking water treatment and observed that the bromate removal decreased from 40 % to 11 % when DO was increased from 2.1 to 13.6 mg/L, indicating a negative impact of DO on bromate reduction. Liu et al. [52] showed that almost complete bromate removal was achieved on influent containing bromate (as 60 µg/L Br<sup>-</sup>) under high DO conditions (8.0 mg/L) when sodium acetate (1 mg/L) was added as exogenous carbon source. DO was reduced from 8 mg/L in the influent to 5.5–6.0 mg/L in the effluent, so oxic conditions prevailed. No bromate removal was observed in a control system in which the BAC had been sterilized before the start-up. This means that the bromate was biologically reduced to bromide in the BAC filter, most likely in anoxic zones within the filter, e.g. in the deeper biofilm surrounding the GAC granules. The carbon source supplied in the influent was utilized as the electron donor for both the reduction of oxygen and bromate.

#### 4.2.3. Influence of methanol on bromate removal under oxic conditions

The addition of methanol increased the bromide formation (i.e. increased bromate reduction) in batch experiment D under oxic conditions. As Fig. 7 shows, when methanol was added bromide formation reached 56 µg/L (batch D) after the first 2 h while without methanol addition (batch C, oxic conditions) bromide formation reached only 19 µg/L. Methanol addition also had a positive effect on the denitrification. These findings are supported by results of Wang et al. [28], who observed a slight but significantly higher nitrate and bromate reduction in batch and column experiments through the addition of acetate as carbon source. Kirisits et al. [36] showed that the increase in DOC as result of addition of an external carbon source resulted in an increased bromate reduction in a BAC filter. The promoting effect of added methanol in the experiments performed in this study may be attributed to the increased availability of electron donors in the batches, allowing for increased reduction of the electron acceptors bromate and nitrate. Addition of methanol enhances both denitrification and bromate reduction, but will result in additional operational costs in practice. This has been evaluated for a full-scale application of the O3-STEP® process (Supplemental Information S5).

## 5. Conclusions

This study focused on the removal of bromate, formed during

ozonation, in a denitrifying GAC filter following ozonation. The combination of ozonation and GAC filtration is applied in the O3-STEP® process, used for removal of nutrients, suspended solids and OMPs from WWTP effluent. The risk of bromate formation during the ozonation may limit the application of this process in practice due to strict regulations for bromate in surface waters, which complicates discharge of treated effluent that contains bromate. In the column and batch experiments described in this study, denitrification took place both under oxic and anoxic conditions. Depletion of oxygen within the biofilm surrounding the GAC granules most probably is the reason for denitrification under oxic bulk conditions, although aerobic denitrification cannot be excluded. The presence of nitrate did not affect bromate removal, whereas the presence of DO had a slight inhibitory effect on bromate removal and nitrate removal. Increase of methanol addition increased both the nitrate and bromate removal, which is hypothesized to occur through an increased availability of electron donors in the water. Ozone - granular activated carbon filtration is an effective process for OMP removal from secondary WWTP effluent as it combines oxidation and adsorption. The denitrifying GAC filter, present in the O3-STEP® process, removes bromate and thus mitigates bromate formation during ozonation. This expands the potential of this process for full scale application. However, this bromate mitigation solution is only applicable in case simultaneous denitrification is required, and should be balanced against additional costs due to the methanol dosing and a more frequent backwashing of the GAC filter due to biomass production. In addition, the formation of oxidation by-products and transformation products by ozonation, such as NDMA [56–58] has not been addressed in this study. This formation, and the subsequent removal during GAC filtration, is a topic for further research into the O3-STEP® process.

## CRedit authorship contribution statement

**Jan Peter van der Hoek:** Writing – review & editing, Writing – original draft, Supervision, Methodology. **Tianyi Deng:** Writing – original draft, Investigation. **Tiza Spit:** Writing – review & editing, Supervision, Investigation. **Veerle Luimstra:** Writing – review & editing, Supervision, Investigation. **Merle de Kreuk:** Writing – review & editing, Supervision. **Doris van Halem:** Writing – review & editing, Supervision.

## Declaration of competing interest

The authors declare that they have no competing financial interests or personal relationships that could have appeared to influence the work reported in this paper.

## Data availability

Data will be made available on request.

## Appendix A. Supplementary data

Supplementary data to this article can be found online at <https://doi.org/10.1016/j.jwpe.2024.104877>.

## References

- [1] Y. Luo, W. Guo, H.H. Ngo, L.D. Nghiem, F.I. Hai, J. Zhang, S. Liang, X.C. Wang, A review on the occurrence of micropollutants in the aquatic environment and their fate and removal during wastewater treatment, *Sci. Total Environ.* 473–474 (2014) 619–641, <https://doi.org/10.1016/j.scitotenv.2013.12.065>.
- [2] A.P. van Wezel, T.L. ter Laak, A. Fischer, P. Bäuerlein, J. Munthe, L. Posthuma, Mitigation options for chemicals of emerging concern in surface waters; operationalising solution-focused risk assessment, *Environmental Science–Water Research & Technology* 3 (2017) 403–414, <https://doi.org/10.1039/C7EW00077D>.
- [3] A. Fischer, T. ter Laak, J. Bronders, N. Desmet, E. Christoffels, A. van Wezel, J. P. van der Hoek, Decision support for water quality management of contaminants of emerging concern, *J. Environ. Manage.* 193 (2017) 360–372, <https://doi.org/10.1016/j.jenvman.2017.02.002>.

- [4] M.O. Barbosa, N.F.F. Moreira, A.R. Ribeiro, M.F.R. Pereira, A.M.T. Silva, Occurrence and removal of organic micropollutants: an overview of the watch list of EU Decision 2015/495, *Water Res.* 94 (2016) 257–279, <https://doi.org/10.1016/j.watres.2016.02.047>.
- [5] C.J. Houtman, J. Kroesbergen, K. Lekkerkerker-Teunissen, J.P. van der Hoek, Human health risk assessment of the mixture of pharmaceuticals in Dutch drinking water and its sources based on frequent monitoring data, *Sci. Total Environ.* 496 (2014) 54–62, <https://doi.org/10.1016/j.scitotenv.2014.07.022>.
- [6] R. Loos, R. Carvalho, D.C. António, S. Comerio, G. Locoro, S. Tavazzi, B. Paracchini, M. Ghiani, T. Lettieri, L. Blaha, B. Jarosova, S. Voorspoels, K. Servaes, P. Haglund, J. Fick, R.H. Lindberg, D. Schwesig, B.M. Gawlik, EU-wide monitoring survey on emerging polar organic contaminants in wastewater treatment plant effluents, *Water Res.* 47 (17) (2013) 6475–6487, <https://doi.org/10.1016/j.watres.2013.08.024>.
- [7] P.R. Rout, T.C. Zhang, P. Bhunia, R.Y. Surampalli, Treatment technologies for emerging contaminants in wastewater treatment plants: a review, *Sci. Total Environ.* 753 (2020) 141990, <https://doi.org/10.1016/j.scitotenv.2020.141990>.
- [8] N. Bolong, A.F. Ismail, M.R. Salim, T. Matsuura, A review of the effects of emerging contaminants in wastewater and options for their removal, *Desalination* 239 (1–3) (2009) 229–246, <https://doi.org/10.1016/j.desal.2008.03.020>.
- [9] J. Reungoat, M. Macova, B.I. Escher, S. Carswell, J.F. Mueller, J. Keller, Removal of micropollutants and reduction of biological activity in a full scale reclamation plant using ozone and activated carbon filtration, *Water Res.* 44 (2010) 625–637, <https://doi.org/10.1016/j.watres.2009.09.048>.
- [10] Y. Tong, P.J. McNamara, B.K. Mayer, Adsorption of organic micropollutants onto biochar: a review of relevant kinetics, mechanisms and equilibrium, *Environ. Sci.: Water Res. Technol.* 5 (2019) 821–838, <https://doi.org/10.1039/C8EW00938D>.
- [11] J. Wang, D. de Ridder, A. van der Wal, N.B. Sutton, Harnessing biodegradation potential of rapid sand filtration for organic micropollutant removal from drinking water: a review, *Crit. Rev. Environ. Sci. Technol.* 51 (18) (2020) 2086–2118, <https://doi.org/10.1080/10643389.2020.1771888>.
- [12] S. Choi, H. Yoom, H. Son, C. Seo, K. Kim, Y. Lee, Y.M. Kin, Removal efficiency of organic micropollutants in successive wastewater treatment steps in a full-scale wastewater treatment plant: bench-scale application of tertiary treatment processes to improve removal of organic micropollutants persisting after secondary treatment, *Chemosphere* 288 (3) (2022) 132629, <https://doi.org/10.1016/j.chemosphere.2021.132629>.
- [13] D.B. Miklos, C. Remy, M. Jekel, K.G. Linden, J.E. Drewes, U. Hübner, Evaluation of advanced oxidation processes for water and wastewater treatment - a critical review, *Water Res.* 139 (2018) 118–131, <https://doi.org/10.1016/j.watres.2018.03.042>.
- [14] J. Hollender, S.G. Zimmermann, S. Koepke, M. Kraus, C.S. McArdell, C. Ort, H. Singer, U. von Gunten, H. Siegrist, Elimination of organic micropollutants in a municipal wastewater treatment plant upgraded with a full-scale post-ozonation followed by sand filtration, *Environ. Sci. Technol.* 43 (20) (2009) 7862–7869, <https://doi.org/10.1021/es9014629>.
- [15] W. Yang, H. Zhou, N. Cicek, Treatment of organic micropollutants in water and wastewater by UV-based processes: a literature review, *Crit. Rev. Environ. Sci. Technol.* 44 (13) (2014) 1443–1476, <https://doi.org/10.1080/10643389.2013.790745>.
- [16] J. Wang, B.A.J. Poursat, J. Feng, D. de Ridder, C. Zhang, A. van der Wal, N. B. Sutton, Exploring organic micropollutant biodegradation under dynamic substrate loading in rapid sand filters, *Water Res.* 22 (2022) 118831, <https://doi.org/10.1016/j.watres.2022.118832>.
- [17] C. Echevarría, C. Valderrama, J.L. Cortina, I. Martín, M. Arnaiz, X. Bernat, A. de la Cal, M.R. Boleda, A. Vega, A. Teuler, E. Castellví, Techno-economic evaluation and comparison of PAC-MBR and ozonation-UV revamping for organic micropollutants removal from urban reclaimed wastewater, *Sci. Total Environ.* 671 (2019) 288–298, <https://doi.org/10.1016/j.scitotenv.2019.03.365>.
- [18] M. Fu, B. Heijman, J.P. van der Hoek, Removal of organic micropollutants from wastewater effluent: selective adsorption by a fixed-bed granular zeolite filter followed by in-situ ozone-based regeneration, *Sep. Purif. Technol.* 303 (2022) 122303, <https://doi.org/10.1016/j.seppur.2022.122303>.
- [19] F. Nilsson, M. Ekblad, J. la Cour Jansen, K. Jönsson, Removal of pharmaceuticals with ozone at 10 Swedish wastewater treatment plants, *Water Practice & Technology* 12 (4) (2017) 871–881, <https://doi.org/10.2166/wpt.2017.087>.
- [20] S. Choi, H. Yoom, H. Son, C. Seo, K. Kim, Y. Lee, Y.M. Kim, Removal efficiency of organic micropollutants in successive wastewater treatment steps in a full-scale wastewater treatment plant: Bench-scale application of tertiary treatment processes to improve removal of organic micropollutants persisting after secondary treatment, *Chemosphere* 288 (Part 3) (2022) 132629, <https://doi.org/10.1016/j.chemosphere.2021.132629>.
- [21] J. Margot, C. Kienle, A. Magnet, M. Weil, L. Rossi, L.F. de Alencastro, C. Abegglen, D. Thoney, N. Chèvre, M. Schäfer, D.A. Barry, Treatment of micropollutants in municipal wastewater: ozone or powdered activated carbon? *Sci. Total Environ.* 461–462 (2013) 480–498, <https://doi.org/10.1016/j.scitotenv.2013.05.034>.
- [22] U. von Gunten, Ozonation of drinking water: part II. Disinfection and by-product formation in the presence of bromide, iodide and chlorine, *Water Res.* 37 (7) (2003) 1469–1487, [https://doi.org/10.1016/S0043-1354\(02\)00458-X](https://doi.org/10.1016/S0043-1354(02)00458-X).
- [23] Y. Schindler Wildhaber, H. Mestankova, M. Schäfer, K. Schirmer, E. Salhi, U. von Gunten, Novel test procedure to evaluate the treatability of wastewater with ozone, *Water Res.* 75 (2015) 324–335, <https://doi.org/10.1016/j.watres.2015.02.030>.
- [24] RIVM, National Institute for Public Health and the Environment, Risk limits for bromate in surface water - determined according to the methodology of the water framework directive, RIVM-briefrapport 2021-0101, Bilthoven, The Netherlands. (2021), <https://doi.org/10.21945/RIVM-2021-0101>.
- [25] Water Forum, Ministry of Infrastructure and Water Sets a Standard for Bromate in Surface Water: 1 Microgram Per Liter, Available, [https://urldefense.com/v3/\\_https://www.waterforum.net/ministerie-ienw-stelt-norm-voor-bromaat-in-oppeervlaktewater-vast-1-microgram-per-liter/\\_!::PAKc-5URQll-zT280dusbnm-Nrf5Dp-bIA92MLajD2yMAA2Gm7uYAUrSNuEPowmnYmgIEAOA1HFIIIPx4o1-0bW9L5it3MTr0QUo5Qs](https://urldefense.com/v3/_https://www.waterforum.net/ministerie-ienw-stelt-norm-voor-bromaat-in-oppeervlaktewater-vast-1-microgram-per-liter/_!::PAKc-5URQll-zT280dusbnm-Nrf5Dp-bIA92MLajD2yMAA2Gm7uYAUrSNuEPowmnYmgIEAOA1HFIIIPx4o1-0bW9L5it3MTr0QUo5Qs), 2022 (Accessed 31 July 2023).
- [26] W.A.M. Hijnen, R. Jong, D. van der Kooij, Bromate removal in a denitrifying bioreactor used in water treatment, *Water Res.* 33 (4) (1999) 1049–1053, [https://doi.org/10.1016/S0043-1354\(98\)00306-6](https://doi.org/10.1016/S0043-1354(98)00306-6).
- [27] W.A.M. Hijnen, R. Voogt, H.R. Veenendaal, H. van der Jagt, D. van der Kooij, Bromate reduction by denitrifying bacteria, *Appl. Environ. Microbiol.* 61 (1) (1995) 239–244, <https://doi.org/10.1128/aem.61.1.239-244.1995>.
- [28] F. Wang, D. van Halem, L. Ding, Y. Bai, K. Lekkerkerker-Teunissen, J.P. van der Hoek, Effective removal of bromate in nitrate-reducing anoxic zones during managed aquifer recharge for drinking water treatment: laboratory-scale simulations, *Water Res.* 130 (2018) 88–97, <https://doi.org/10.1016/j.watres.2017.11.052>.
- [29] U. Hübner, S. Kuhn, M. Jekel, J.E. Drewes, Fate of bulk organic carbon and bromate during indirect water reuse involving ozone and subsequent aquifer recharge, *Journal of Water Reuse and Desalination* 6 (3) (2016) 413–420, <https://doi.org/10.2166/wrd.2015.222>.
- [30] C.Y. de Jong, A.F. van Nieuwenhuijzen, A. Dekker, T.K. Liu, S.J.S. de Smet, Proof of concept and laboratory research removal micropollutants from WWTP effluent with the O3-STEP® filter. Stowa report 2018-67, ISBN 978.90.5773.826.5, Stowa, Amersfoort, The Netherlands (2018) (in Dutch).
- [31] M.L. Bao, O. Griffini, D. Santianni, K. Barbieri, D. Burrini, F. Pantani, Removal of bromate ion from water using granular activated carbon, *Water Res.* 33 (13) (1999) 2959–2970, [https://doi.org/10.1016/S0043-1354\(99\)00015-9](https://doi.org/10.1016/S0043-1354(99)00015-9).
- [32] M.J. Kirisitis, V.L. Snoeyink, J.C. Kruithof, The reduction of bromate by granular activated carbon, *Water Res.* 34 (17) (2000) 4250–4260, [https://doi.org/10.1016/S0043-1354\(00\)00189-5](https://doi.org/10.1016/S0043-1354(00)00189-5).
- [33] B.N. Jahan, L. Li, K.R. Pagilla, Fate and reduction of bromate formed in advanced water treatment ozonation systems: a critical review, *Chemosphere* 266 (2021) 128964, <https://doi.org/10.1016/j.chemosphere.2020.128964>.
- [34] W. Lee, S. Choi, H. Kim, W. Lee, M. Lee, H. Son, C. Lee, M. Cho, Y. Lee, Efficiency of ozonation and O<sub>3</sub>/H<sub>2</sub>O<sub>2</sub> as enhanced wastewater treatment processes for micropollutant abatement and disinfection with minimized byproduct formation, *J. Hazard. Mater.* 454 (2023) 131436, <https://doi.org/10.1016/j.jhazmat.2023.131436>.
- [35] Y.H. Chuang, W.A. Mitch, Effect of ozonation and biological activated carbon treatment of wastewater effluents on formation of N-nitrosomonas and halogenated disinfection by-products, *Environ. Sci. Technol.* 51 (2017) 2329–2338, <https://doi.org/10.1021/acs.est.6b04693>.
- [36] M.J. Kirisitis, V.L. Snoeyink, H. Inan, J.C. Chee-sanford, L. Raskin, J.C. Brown, Water quality factors affecting bromate reduction in biologically active carbon filters, *Water Res.* 35 (4) (2001) 891–900, [https://doi.org/10.1016/S0043-1354\(00\)00334-1](https://doi.org/10.1016/S0043-1354(00)00334-1).
- [37] STOWA Foundation for Applied Water Research, Pilot plant research O3-STEP. Report 2023–24 STOWA, ISBN 978.94.6479.044.3, Amersfoort, The Netherlands (in Dutch), <https://www.stowa.nl/onderwerpen/waterkwaliteit/nieuwe-stoffen/pilotonderzoek-o3-step-ipmv>, 2023.
- [38] M.J. Kirisitis, V.L. Snoeyink, Reduction of bromate in a BAC filter, *J. Am. Water Works Assoc.* 91 (8) (1999) 74–84, <https://doi.org/10.1002/j.1551-8833.1999.tb08684.x>.
- [39] W.J. Huang, H.S. Peng, M.Y. Peng, L.Y. Cheng, Removal of bromate and assimilable organic carbon from drinking water using granular activated carbon, *Water Science & Technology* 50 (8) (2004) 73–80, <https://doi.org/10.2166/wst.2004.0492>.
- [40] S. Seitzinger, J.A. Harrison, J.K. Böhlke, A.F. Bouwma, R. Lowrance, B. Peterson, C. Tobias, G. Van Drecht, Denitrification across landscapes and waterscapes: a synthesis, *Ecol. Appl.* 16 (6) (2006) 2064–2090, [https://doi.org/10.1890/1051-0761\(2006\)016\[2064:DALAWA\]2.0.CO;2](https://doi.org/10.1890/1051-0761(2006)016[2064:DALAWA]2.0.CO;2).
- [41] M.J. Kampschreur, H. Temmink, R. Kleerebezem, M.S. Jetten, M.C.M. van Loosdrecht, Nitrous oxide emission during wastewater treatment, *Water Res.* 43 (2009) 4093–4103, <https://doi.org/10.1016/j.watres.2009.03.001>.
- [42] X. Liu, Y. Wu, R. Sum, S. Hu, Z. Qiao, S. Wang, X. Mi, NH<sub>4</sub><sup>+</sup>-N/NO<sub>3</sub><sup>-</sup>-N ratio controlling nitrogen transformation accompanied with NO<sub>2</sub><sup>-</sup>-N accumulation in the oxic-anoxic transition zone, *Environ. Res.* 189 (2020) 109962, <https://doi.org/10.1016/j.envres.2020.109962>.
- [43] S.F. Korom, Natural denitrification in the saturated zone: a review, *Water Research* 28 (6) (1992) 1657–1668, <https://doi.org/10.1029/92WR00252>.
- [44] J.H. Luo, M. Wu, Z. Yuan, J. Guo, Biological bromate reduction driven by methane in a membrane biofilm reactor, *Environ. Sci. Technol. Lett.* 4 (12) (2017) 562–566, <https://doi.org/10.1021/acs.estlett.7b00488>.
- [45] H. Ridley, C.A. Watts, D.J. Richardson, C.S. Butler, Resolution of distinct membrane-bound enzymes from *Enterobacter cloacae* SLD1a-1 that are responsible for selective reduction of nitrate and selenate oxyanions, *Appl. Environ. Microbiol.* 72 (8) (2006) 5173–5180, <https://doi.org/10.1128/aem.00568-06>.
- [46] Y. Zhong, Q. Yang, G. Fu, Y. Xu, Y. Cheng, C. Chen, R. Xiang, T. Wen, X. Li, G. Zeng, Denitrifying microbial community with the ability to bromate reduction in a rotating biofilm-electrode reactor, *J. Hazard. Mater.* 342 (2018) 150–157, <https://doi.org/10.1016/j.jhazmat.2017.08.019>.
- [47] L.A. Robertson, J.G. Kuenen, Aerobic denitrification – old wine in new bottles? *Antonie Van Leeuwenhoek* 50 (5–6) (1984) 525–544, <https://doi.org/10.1007/BF02386224>.

- [48] F. Wang, J. Pan, Y. Hu, J. Zhou, H. Wang, X. Huang, W. Chu, J.P. van der Hoek, Effects of biological activated carbon filter running time on disinfection by-product precursor removal, *Sci. Total Environ.* 838 (2022) 155936, <https://doi.org/10.1016/j.scitotenv.2022.155936>.
- [49] Z. Liang, Q. Tu, X. Su, X. Yang, J. Chen, Y. Chen, H. Li, C. Liu, Q. He, Formation, extracellular polymeric substances, and structural stability of aerobic granules enhanced by granular activated carbon, *Environ. Sci. Pollut. Res.* 26 (6) (2019) 6123–6132, <https://doi.org/10.1007/s11356-018-04101-1>.
- [50] K. Joshi, N. Lokeshwari, G. Srinikethan, M.B. Saidutta, Denitrification under aerobic condition in draft tube spouted bed reactor, in: B. Mohan, R., Srinikethan, G., Meikap, B. (Eds.), *Materials, Energy and Environment Engineering*, Springer, Singapore, 2017, pp. 85–92, [https://doi.org/10.1007/978-981-10-2675-1\\_10](https://doi.org/10.1007/978-981-10-2675-1_10).
- [51] B. Ji, K. Yang, L. Zhu, Y. Jiang, H. Wang, J. Zhou, H. Zhang, Aerobic denitrification: a review of important advances of the last 30 years, *Biotechnol. Bioprocess Eng.* 20 (4) (2015) 643–651, <https://doi.org/10.1007/s12257-015-0009-0>.
- [52] J. Liu, J. Yu, D. Li, Y. Zhang, M. Yang, Reduction of bromate in a biological activated carbon filter under high bulk dissolved oxygen conditions and characterization of bromate-reducing isolates, *Biochem. Eng. J.* 65 (2012) 44–50, <https://doi.org/10.1016/j.bej.2012.04.004>.
- [53] B. Ji, H. Wang, K. Yang, Tolerance of an aerobic denitrifier (*Pseudomonas stutzeri*) to high O<sub>2</sub> concentrations, *Biotechnol. Lett.* 36 (2014) 719–722, <https://doi.org/10.1007/S10529-013-1417-X>.
- [54] H.K. Marchant, S. Ahmerkamp, G. Lavik, H.E. Tegetmeyer, J. Graf, J.M. Klatt, M. Holtappels, E. Walpersdorf, M.M.M. Kuypers, Denitrifying community in coastal sediments performs aerobic and anaerobic respiration simultaneously, *ISME J.* 11 (2017) 1799–1812, <https://doi.org/10.1038/ismej.2017.51>.
- [55] Z.-L. Hao, A. Ali, Y. Ren, J.-F. Su, Z. Wang, A mechanistic review o aerobic denitrification for nitrogen removal in water treatment, *Sci. Total Environ.* 847 (2022) 157452, <https://doi.org/10.1016/j.scitotenv.2022.157452>.
- [56] Y. Song, S. Feng, W. Qin, J. Li, C. Guan, Y. Zhou, Y. Gao, Z. Zhang, J. Jiang, Formation mechanism and control strategies for N-nitrosodimethylamine (NDMA) formation during ozonation, *Sci. Total Environ.* 823 (2022) 153679, <https://doi.org/10.1016/j.scitotenv.2022.153679>.
- [57] E. Borowska, M. Bourgin, J. Hollender, C. Kienle, C.S. McArdell, U. von Gunten, Oxidation of cetirizine, fexofenadine and hydrochlorothiazide during ozonation: kinetics and formation of transformation products, *Water Res.* 94 (2016) 350–362, <https://doi.org/10.1016/j.watres.2016.02.020>.
- [58] R. Gulde, M. Rutsch, B. Clerc, J.E. Schollée, U. von Gunten, C.S. McArdell, Formation of transformation products during ozonation of secondary wastewater effluent and their fate in post-treatment: from laboratory- to full-scale, *Water Res.* 200 (2021) 117200, <https://doi.org/10.1016/j.watres.2021.117200>.