

**Advancements and insights in thermal and water management of proton exchange membrane fuel cells
Challenges and prospects**

Zhang, Zhenya; Mao, Jia; Liu, Zhengxuan

DOI

[10.1016/j.icheatmasstransfer.2024.107376](https://doi.org/10.1016/j.icheatmasstransfer.2024.107376)

Publication date

2024

Document Version

Final published version

Published in

International Communications in Heat and Mass Transfer

Citation (APA)

Zhang, Z., Mao, J., & Liu, Z. (2024). Advancements and insights in thermal and water management of proton exchange membrane fuel cells: Challenges and prospects. *International Communications in Heat and Mass Transfer*, 153, Article 107376. <https://doi.org/10.1016/j.icheatmasstransfer.2024.107376>

Important note

To cite this publication, please use the final published version (if applicable).
Please check the document version above.

Copyright

Other than for strictly personal use, it is not permitted to download, forward or distribute the text or part of it, without the consent of the author(s) and/or copyright holder(s), unless the work is under an open content license such as Creative Commons.

Takedown policy

Please contact us and provide details if you believe this document breaches copyrights.
We will remove access to the work immediately and investigate your claim.



Advancements and insights in thermal and water management of proton exchange membrane fuel cells: Challenges and prospects

Zhenya Zhang^a, Jia Mao^a, Zhengxuan Liu^{b,*}

^a School of Energy and Power Engineering, Zhengzhou University of Light Industry, Zhengzhou 450001, China

^b Faculty of Architecture and the Built Environment, Delft University of Technology, Julianalaan 134, 2628 BL Delft, Netherlands

ARTICLE INFO

Keywords:

Proton exchange membrane fuel cells (PEMFCs)
Thermal management
Water management
High-power heat dissipation
Clean energy

ABSTRACT

In response to the growing global demand for clean and sustainable energy solutions, proton exchange membrane fuel cells (PEMFCs) have emerged as vital components in diverse decarbonization strategies. Despite their increasing importance, a comprehensive synthesis of recent advancements, challenges, and future prospects in thermal and water management within this domain remains notably scarce. This paper aims to bridge this gap by conducting a meticulous literature review focused on thermal and water management in PEMFCs. Primarily, this study encapsulates the underlying mechanisms governing thermal and water generation in PEMFCs, intricately analyzing thermal and water generation analyses. Secondly, a multifaceted exploration of thermal and water transfer mechanisms, alongside their pivotal influencing factors, is presented. Furthermore, the discourse delves into sophisticated strategies for refining water and thermal management in PEMFCs. As well as delving into the complexities of high-power heat dissipation and water balance, especially water management for cold start and high temperature operating conditions. The culmination of this investigation yields valuable insights into the intricate dynamics of thermal and water management within PEMFCs, thereby culminating in forward-looking recommendations for future research trajectories. These findings not only offer scholars a vantage point to discern emerging research frontiers and trends but also extend theoretical precepts and reference points for technology innovators and product developers.

1. Introduction

With the increasingly serious problems of environmental pollution and energy shortage, it is of great significance to explore the use of renewable energy to replace the conventional fossil fuel energy sources. In this context, the proportion of clean and sustainable energy in the practical applications of energy systems is gradually increasing [1]. Hydrogen energy is an efficient and clean renewable energy with distinct advantages such as wide sources, transport and storage options, high utilization efficiency and energy density [2–4], which has been extensively explored and studied in recent years.

The utilization of hydrogen energy includes four stages: production, storage, transportation and utilization [5]. Among them, the efficient conversion and utilization of hydrogen energy plays a crucial role. As an integral part of the utilization of hydrogen energy, proton exchange membrane fuel cell (PEMFC) is a device that converts chemical energy into electrical energy. The PEMFC has the characteristics of fast startup speed, high power generation efficiency and high-power density, also

including the working process without being limited by Carnot cycle. Its energy conversion efficiency can reach 40% ~ 60%, with reaction products of no pollution for environment, which is suitable for new energy vehicles, fixed power stations, and other fields [6–8]. The optimal operating temperature range for a low temperature PEMFC typically falls within 60–80 °C [9]. Operating at lower temperatures can pose challenges in starting PEMFCs, particularly in environments reaching 0 °C, as water freezing can lead to ice blockage. Conversely, higher temperatures accelerate the degradation of both the PEM and catalyst layer (CL), consequently reducing the operational lifespan of the fuel cell. Furthermore, a low water content diminishes the conductivity of the proton exchange membrane. Conversely, excessive water content within the fuel cell can result in flooding, leading to increased diffusion resistance [10,11]. Thus, the reliability of the water and thermal management system is of utmost importance to ensure the safe, stable, and efficient operation of PEMFC.

In recent years, numerous researchers have carried out extensive studies on the thermal and water management technology of PEMFC. Chen et al. [12] reviewed the latest development of thermal

* Corresponding author.

E-mail address: Z.liu-12@tudelft.nl (Z. Liu).

Nomenclature		ϕ	Potential, V
<i>Symbols</i>		χ	Mole fraction
A	Area, cm ²	<i>Subscripts</i>	
c	Gas concentration, mol/m ³	0	Reference
C	Specific heat	an	Anode
D	Diffusion coefficient	c	Capillary
E	Voltage, V	ca	Cathode
F	Faraday constant, C/mol	cell	Fuel cell
H	Enthalpy value, J/mol	cl	Coolant
H_2	Hydrogen	con	Condensation
H_2O	Water	e ⁻	Electronic
i	Current density, A/cm ²	eq	Equilibrium
I	Current, A	evp	Evaporation
J	Flux, mol m ⁻² s ⁻¹	gas	Reaction gas
k	Mass transfer coefficient	gen	Generate
M	Molar mass	hyd	Hydraulic
N	Gas flow, kg/s	hum	Humidification
N_2	Nitrogen	H ⁺	Hydrogen ion
O_2	Oxygen	H ₂ O	Water (vapor)
p	Pressure, N	in	Flow into
Q	Thermal energy, W	irev	irreversible
R	Gas constant, J/mol K	l	Liquid water
RH	Relative humidity	ohm	Ohmic
s	Liquid water saturation	out	Flow out
S	Stoichiometric ratio	rad	Radiation
T	Temperature, K	rev	Reversible
W	Coolant or water flow, kg/s, mol	sat	Saturation
<i>Greeks</i>		tot	Total
α	Transport coefficient, mol ² ·J ⁻¹ ·cm ⁻¹ ·s ⁻¹	<i>Abbreviations</i>	
γ	Phase change rate, s ⁻¹	3D	Three-dimensional
ϵ	Porosity	CL	Catalyst layer
η	Overpotential, V	GDL	Gaseous diffusion layer
θ	Contact angle, °	H ₂	Hydrogen
κ	Permeability	H ₂ O	Water vapor
λ	Ionomer water content	IUT	Temperature uniformity index
μ	Chemical potential, V	MPC	Model predictive control
ξ	Electroosmotic coefficient	MPL	Microporous layer
σ	Conductivity, S/cm	O ₂	Oxygen
τ	Permeability	PEMFC	Proton exchange membrane fuel cell

management, and discussed in depth the waste heat generation mechanism, cooling methods, cold start, and related material properties and durability in the fuel cell. They discovered that the coupling analysis of thermal and water management is a challenging subject for improving the performance of system energy efficiency. Wang et al. [13] described in detail the effects of water content on the cathode, anode, gas diffusion layer (GDL), CL and flow channel. Wilberforce et al. [14] comprehensively analyzed the possibility of thermal recovery of the PEMFC, the results indicated that exploiting possibilities for fuel cell heat recovery may significantly improve size and cost, while also reducing its total energy consumption.

It is noteworthy that summarizing and discussing the problems and challenges in the existing research on PEMFC is more conducive to promoting technological innovation. Therefore, a systematic review is valuable to show the latest research progress, research hotspots, challenges encountered, and future perspectives of PEMFC. The originality and novelty of this study include: 1) Systematic summarization and analysis of the thermal management system and its control strategy, waste heat recovery, and utilization, considering the thermal and water generation analysis, and influencing factors; 2) Highlighting the bottlenecks in the application and development of water and thermal

management technology for PEMFC, and discussing the current challenges in different application scenarios; 3) Providing implementation recommendations and research directions for water and thermal management technology of PEMFC, considering various application scenarios. Overall, this study offers scientific research hotspots and trends for academics, along with theoretical guidelines and references for technology researchers and product developers.

2. Methodology

This study endeavors to thoroughly investigate the water and thermal management strategies employed in fuel cells, emphasizing a systematic approach. The research progress in the field of water and thermal management for fuel cells is methodically examined through a meticulous search of pertinent literature using carefully curated keywords. A graphical representation of the keyword combinations adopted during the database search is showcased in Fig. 1.

The related literature was investigated in detail and divided into four major combinations based on the type of keywords, as shown in Fig. 1. This article presents a comprehensive systematic review of water and thermal management in fuel cells and their development trends, with a

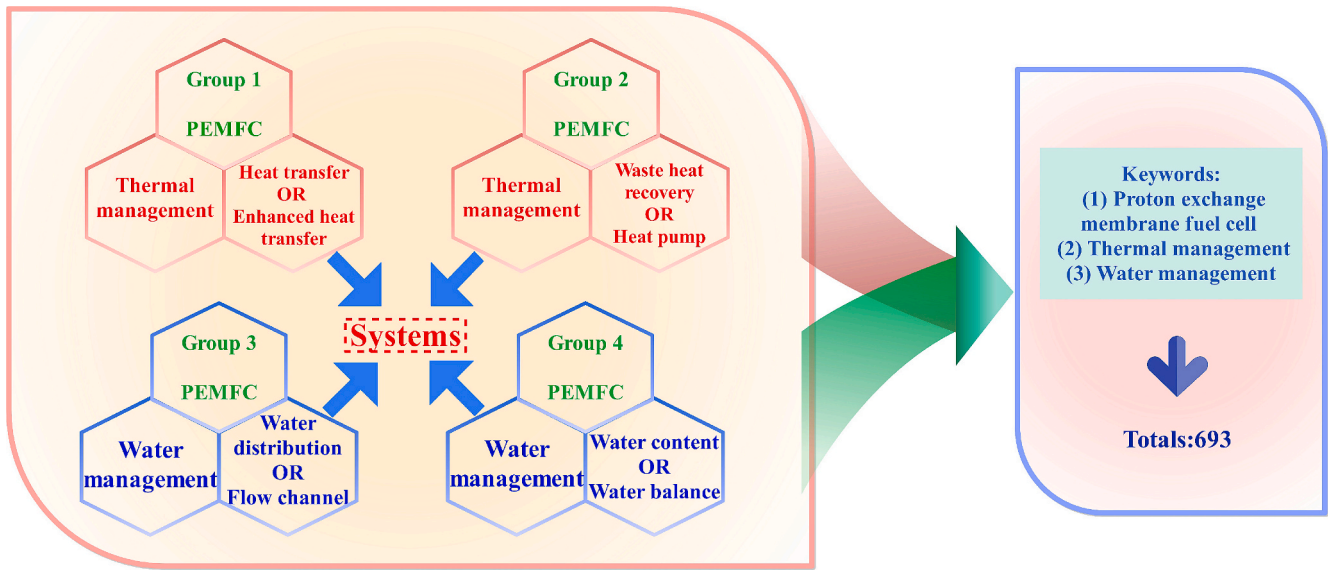

Fig. 1. The coordination of keywords for systematic review.

focus on the time frame of 2015 to 2023. Some of the basic theoretical knowledge references are not included within this scope. A total of 693 articles related to water and thermal management of PEMFC were identified using four sets of keywords. To initially obtain literature related to PEMFC water and thermal management, the initial conditions of fuel cell and water management, and fuel cell and thermal management, were first filtered, resulting in 296 and 102 articles, respectively. Further literature related to enhancing the performance of thermal management systems was obtained by searching keywords such as enhanced heat transfer, waste heat recovery, and heat pumps, resulting in a list of 50 papers. Additionally, 186 papers were retrieved on water content and its distribution. It is worth mentioning that a portion of the research was sourced through references, facilitating access to further studies in the field. Overall, this systematic approach allowed for a comprehensive examination of relevant literature related to water and thermal management strategies in fuel cells, enabling the identification of key trends and advancements in the field.

The paper's research framework consists of seven sections that comprehensively cover the thermal and water management of PEMFC. Section 3 outlines the heat and water generation mechanisms and their transfer mechanisms in the PEMFC, analyzing various factors that may affect these mechanisms. It also focuses on the thermal management system structure and control strategies, including a discussion of high-power heat dissipation. In Section 4, the performance of the fuel cell system is improved through waste heat recovery, temperature difference power generation, and heat pump technologies, as well as analysis of the thermal management of the cold start process. Section 5 focuses on ways to enhance water management, summarizing the factors that may affect the water balance and water content ranges, and related improvements. A comprehensive analysis of water management for cold starts at low temperatures ($<0^\circ\text{C}$) and high operating temperatures was performed. Finally, Section 6 provides a summary of the current research situation, presents existing technical problems and challenges, and outlines prospects for future research.

3. Advancements in thermal and water management for PEMFC

3.1. Advancements in thermal generation analysis within PEMFC

According to the study of Kandlikar et al. [15] and Ramousse et al. [16], the heat sources during the operation of PEMFC mainly include the following aspects: ohmic resistance, irreversible reaction, entropic

change of electrochemical reaction and the enthalpy change due to condensation or vaporization of water. The calculation expression of total heat production is:

$$Q_{\text{tot}} = Q_{\text{ohm}} + Q_{\text{irev}} + Q_{\text{rev}} + Q_{\text{eva/con}} \quad (1)$$

The heat production of ohmic resistance is caused by ionic resistance and electronic resistance [17], which is calculated as:

$$Q_{\text{ohm,H}^+} = \frac{i_{\text{H}^+}^2}{\sigma_{\text{H}^+}} \quad (2)$$

$$Q_{\text{ohm,e}^-} = \frac{i_{\text{e}^-}^2}{\sigma_{\text{e}^-}} \quad (3)$$

Where i_{H^+} and i_{e^-} are the ion and electron current density (A/cm^2), σ_{H^+} and σ_{e^-} are the ionic and electron conductivity (S/cm).

Ju et al. [18] and Wang [19] found that the cathode has a high potential due to the redox reaction, and the irreversible electrochemical reaction heat is mainly concentrated on the cathode, which can be calculated according to Eq. (4):

$$Q_{\text{irev}} = I_{\text{cell}}\eta \quad (4)$$

Where I_{cell} is the current (A), η is the overpotential (V).

Reversible heat comes from entropy change in the electrochemical reaction, expressed as:

$$Q_{\text{rev}} = I_{\text{cell}}T_{\text{cell}}\frac{dE_{\text{eq}}}{dT_{\text{cell}}} \quad (5)$$

Where T_{cell} is the temperature (K), E_{eq} is the equilibrium potential (V).

The evaporation or condensation process of water involves the release of entropy heat, which can be calculated using the following Eq. (20):

$$Q_{\text{evp/con}} = \begin{cases} H_{\text{evp}}\gamma_{\text{evp}}c(\chi_{\text{H}_2\text{O}} - \chi_{\text{sat}}) & \text{if } \chi_{\text{H}_2\text{O}} < \chi_{\text{sat}} \\ H_{\text{con}}\gamma_{\text{con}}c(\chi_{\text{H}_2\text{O}} - \chi_{\text{sat}}) & \text{if } \chi_{\text{H}_2\text{O}} > \chi_{\text{sat}} \end{cases} \quad (6)$$

Where H_{evp} and H_{con} are the enthalpy value of evaporation and condensation (J/mol), γ_{evp} and γ_{con} are the evaporation and condensation rates ($1/\text{s}$), c is the total interstitial gas concentration (mol/m^3), $\chi_{\text{H}_2\text{O}}$ and χ_{sat} are the mole fraction of water vapor and saturated state water vapor.

In addition to the above heat generation calculation methods, there is a relationship between the heat generated and its operating voltage in the PEMFC. The heat generation can be determined using the relation-

ship between the operating voltage and the thermoneutral voltage of a single cell [21], whose expression is given by:

$$Q_{gen} = (E_{th} - E_{cell}) \cdot i_{cell} \cdot A_{cell} \quad (7)$$

Where Q_{gen} is the heat production (W), E_{th} is the thermoneutral voltage (V), E_{cell} is the actual operating voltage (V), i_{cell} is the current density (A/cm^2), A_{cell} is the activation area (cm^2).

According to the polarization curve of PEMFC, the current density will decrease with the increase of voltage [22]. As demonstrated by Eq. (7), when the activation area of the fuel cell is fixed, the heat production increases with the decline in cell voltage and the corresponding increase in current density. Thus, a thorough analysis of heat and mass transfer within the PEMFC is essential to maintain an optimal operating environment.

3.2. Advancements in water generation analysis within PEMFC

During the electrochemical reaction, water starts to accumulate inside the PEMFC and gradually spreads to the low concentration region. Under the combined effect of gas flow and pressure difference, the liquid water in the flow channel is discharged. Fig. 2 illustrates the dynamics of water under normal operating conditions. The water mainly comes from the humidification of reaction gas and electrochemical reaction by-products [23]. The calculation expressions of gas humidification amount and water generated by electrochemical reaction are respectively [24]:

$$W_{hum} = \frac{RH_{ca} \cdot P_{sat}}{P_c - RH_{ca} \cdot P_{sat}} \cdot \frac{S_{ca}}{0.21} \cdot \frac{i_{cell} \cdot A_{cell}}{4 \cdot F} \quad (8)$$

$$W_{gen} = \frac{i_{cell} \cdot A_{cell}}{2 \cdot F} \quad (9)$$

Where RH_{ca} is the relative humidity of cathode, P_{sat} is the pressure in saturation state (atm), P_c is the capillary pressure (Pa), S_{ca} is the cathode stoichiometric ratio, F is the Faraday constant (C/mol).

The oxygen reduction reaction occurs at the triple phase boundary where catalytically active electrode particles, the electrolyte phase, and gas pores intersect. The generated water is concentrated between the cathode CL and PEM [25,26]. This water is in the form of water vapor and is diffused and transported to the GDL and PEM [27,28]. Flipo et al. [29] conducted experimental research indicating that liquid water in the gas channel primarily originates from direct steam condensation within the gas channel, condensation at the interface between the electrode plate and GDL, and liquid water flow into the gas channel within the GDL. The rate of water vapor evaporation or condensation is calculated as [20]:

$$\begin{aligned} \gamma_{evp} &= k_{evp} a_{lg} s_{red} \\ \gamma_{con} &= k_{con} a_{lg} (1 - s_{red}) \end{aligned} \quad (10)$$

Where a_{lg} is an effective liquid-gas interfacial surface area density scaling factor (m^2/cm^2), s_{red} is the reduced liquid water saturation, $s_{red} = \frac{s - s_c}{1 - s_c}$, k_{evp} and k_{con} are the Hertz-Knudsen mass transfer coefficients, given at atmospheric pressure by [30].

$$\left. \begin{aligned} k_{evp} \\ k_{con} \end{aligned} \right\} = \sqrt{\frac{RT}{2\pi M_1}} \times \begin{cases} 5 \times 10^{-4} \\ 6 \times 10^{-3} \end{cases} \quad (11)$$

Where R is the gas constant (J/mol K), M_1 is the molar mass of water (kg/mol).

3.3. Unraveling the complexities: mechanistic insights and influential factors in thermal and water transport within PEMFC

According to the thermal and water generation analysis of PEMFC, it

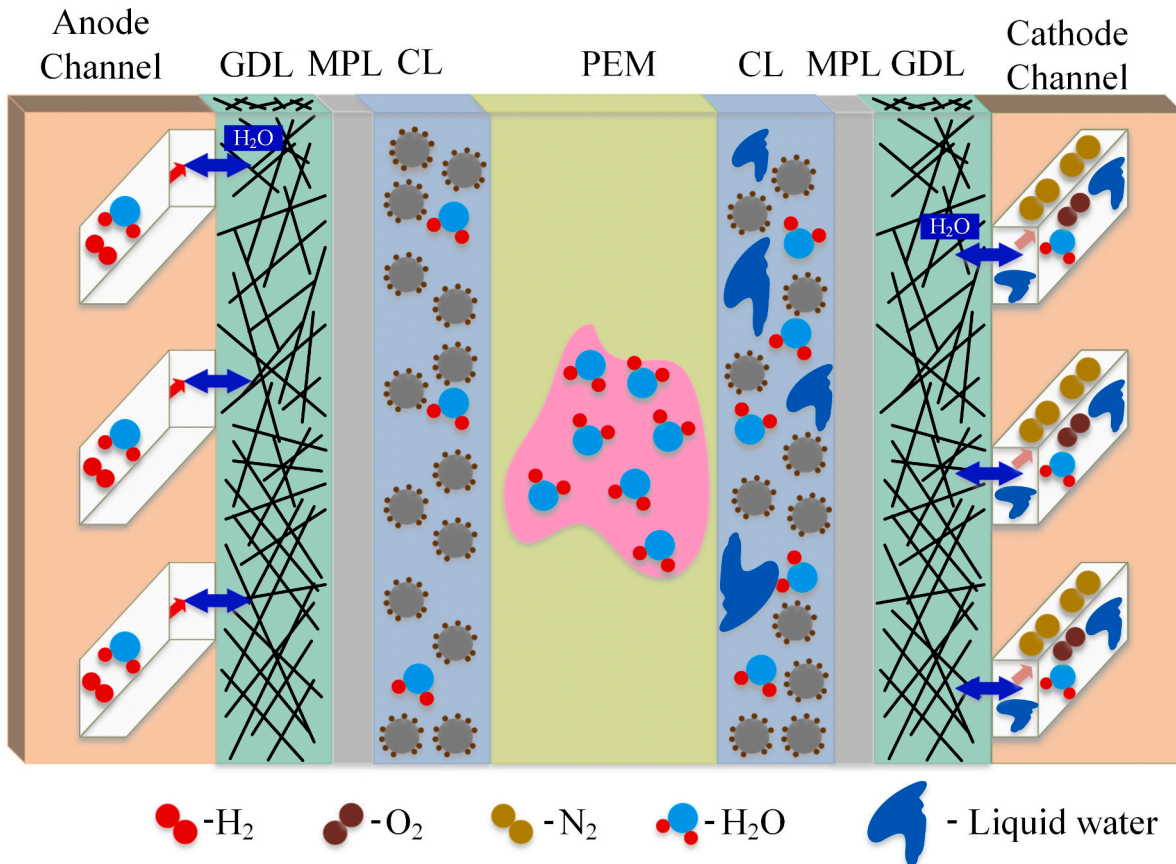

Fig. 2. Water dynamics in PEMFC [24].

is known that the operating environment and parameters will affect the performance of PEMFC [31], which mainly relies on the cooling channel and thermal management system to regulate the internal liquid heat and water. Optimization of their structural design has positive significance for improving the temperature and water distribution uniformity within PEMFC [32,33]. Therefore, the researchers investigated the performance of different component structures for good thermal and water management through experiments and simulations.

3.3.1. Navigating the intricacies of thermal energy transfer and influential factors

3.3.1.1. Decoding thermal energy transfer pathways within PEMFC. Fig. 3 shows the schematic diagram of heat transfer inside the PEMFC, and involved forms of energy transfer mainly include heat conduction, heat convection and heat radiation [12,34]. The internal reaction heat, latent heat and sensible heat successively pass through the CL, GDL and gas flow channel by means of heat conduction. And heat exchange is carried out with the coolant through convection heat exchange to meet the requirements of reducing internal temperature. The quantity of heat is transferred to the external environment through unreacted reactants, evaporation latent heat of water, natural convection and cooling system [35]. Among them, a larger of the heat energy needs to be transferred by the coolant to reduce the temperature, avoid local hot spots and improve the durability of the PEMFC [36].

Based on the calculation equation of heat production and heat load, Zhao et al. [38] analyzed and summarized the calculation equation of heat dissipation from the fuel cell by coolant according to the heat balance equation as follows:

$$Q_{cl} = W_{cl} C_{cl} (T_{cl,out} - T_{cl,in}) \quad (12)$$

Where W_{cl} is the flow of coolant (kg/s), C_{cl} is the specific heat capacity of coolant (J/(kg·K)), $T_{cl,out}$ and $T_{cl,in}$ are the outlet and inlet temperature of coolant (K).

Take the difference between the heat of unreacted gas and the total gas when entering the fuel cell as the total heat dissipation of gas, expressed as [39]:

$$Q_{gas} = Q_{out} - Q_{in} \quad (13)$$

According to the heat balance equation, the heat of the reaction gas entering the fuel cell is:

$$Q_{in} = \left(N_{an,H_2}^{in} C_{H_2} - N_{an,H_2O}^{in} C_{H_2O}^g \right) (T_{an}^{in} - T_0) + \left(N_{ca,air}^{in} C_{air} - N_{ca,H_2O}^{in} C_{H_2O}^g \right) (T_{ca}^{in} - T_0) \quad (14)$$

Where N_{an,H_2}^{in} is the anode inlet hydrogen flow (kg/s), $N_{ca,air}^{in}$ is the cathode inlet air flow (kg/s), N_{ca,H_2O}^{in} is the cathode inlet water vapor flow rate (kg/s), N_{an,H_2O}^{in} is the anode inlet water vapor flow rate (kg/s), C_{H_2} is the specific heat volume of hydrogen (J/(kg·K)), $C_{p,air}$ is the specific heat volume of air (J/(kg·K)), $C_{H_2O}^g$ is the specific heat volume of water vapor (J/(kg·K)), T_0 is the standard atmospheric temperature (K).

The heat of the unreacted gas as it flows out of the cell:

$$Q_{out} = N_{an,H_2}^{out} C_{H_2} (T_{an}^{out} - T_0) + \left(N_{ca,H_2O}^{out} C_{H_2O}^g + N_{ca,H_2O,l}^{out} C_{H_2O}^l \right) (T_{ca}^{out} - T_0) + \left(N_{ca,O_2}^{out} C_{O_2} + N_{ca,N_2}^{out} C_{N_2} \right) (T_{ca}^{out} - T_0) \quad (15)$$

Where N_{an,H_2}^{out} is the anode outlet hydrogen flow (kg/s), N_{ca,O_2}^{out} is the cathode outlet air flow (kg/s), N_{ca,N_2}^{out} is the cathode outlet nitrogen flow (kg/s), N_{ca,H_2O}^{out} is the cathode outlet water vapor flow rate (kg/s), T_{an}^{out} and T_{ca}^{out} are the anode and cathode outlet temperature (K), C_{O_2} , C_{N_2} and $C_{H_2O}^l$ are the specific heat volume of oxygen, nitrogen and liquid water (J/(kg·K)), respectively.

As the operating temperature is higher than the ambient temperature, the heat emitted to the surrounding environment through thermal radiation, can be expressed as [40].

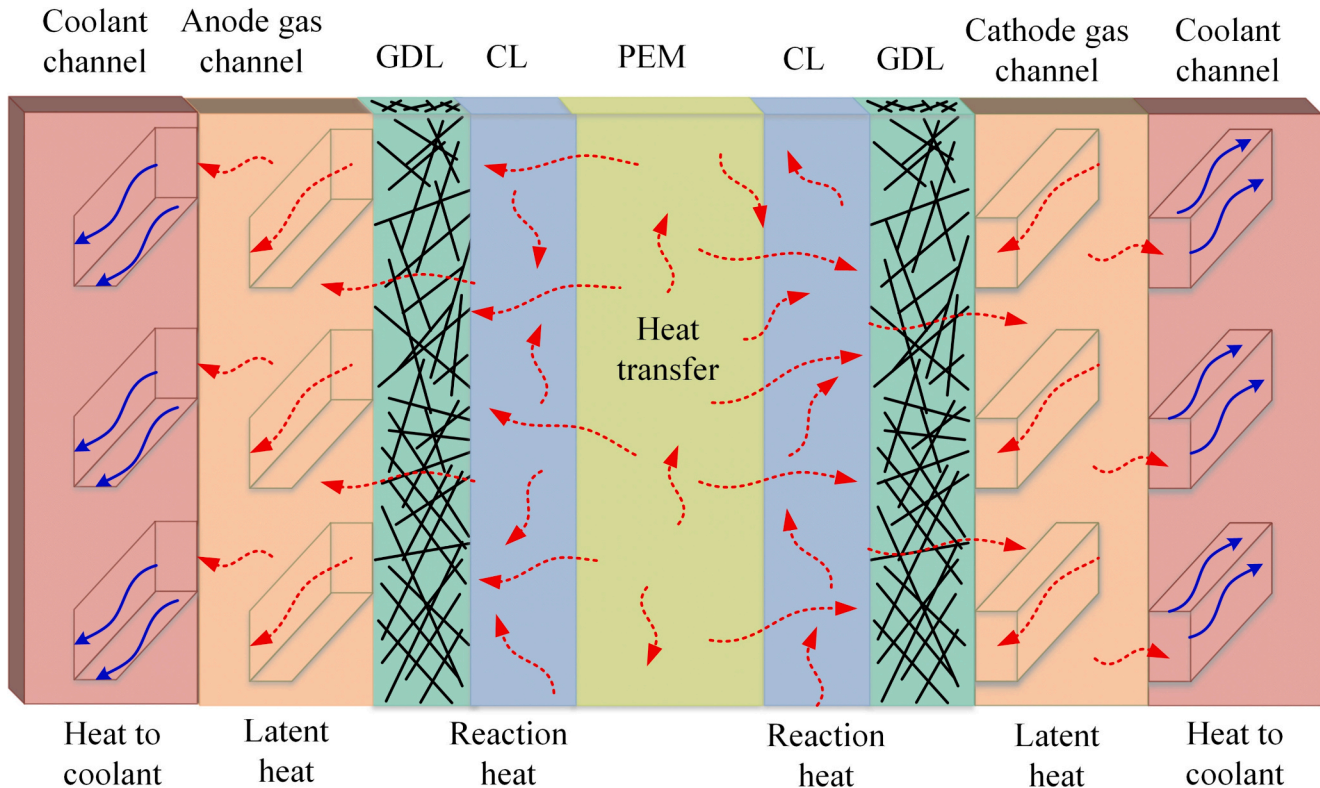

Fig. 3. Schematic diagram of heat inside the PEMFC [37].

$$Q_{\text{rad}} = 5.67 \times 10^{-8} A_{\text{rad}} [(T_{\text{cell}})^4 - (T_0)^4] \quad (16)$$

3.3.1.2. Discerning factors and flow field on thermal transfer within PEMFC. According to the results of Shabani and Andrews [41], it can be seen that about 45% of the input energy is released in the form of thermal energy. Among the heat generated, 11.1% is used for the evaporation of water inside the fuel cell, the heat dissipated by reactants and natural convection. About 36% of the heat needs to be released through the cooling system.

The performance of the thermal management system in PEMFCs is affected by various factors, including cooling methods, coolant properties, radiator performance, and others. Ghasemi et al. [42] showed the best performance of serpentine flow field over other forms of flow field by simulation analysis. Chen et al. [43] carried out a numerical study of a new type of the runner with the holes between cooling channel and cathode channel. They found that the flow field performance of the PEMFC is the best when the optimal single hole parameter is 0.4 mm in length, 0.5 mm in width and at the position of 20 mm. Baek et al. [44] evaluated the characteristics of six coolant flow fields in terms of three parameters: maximum temperature, temperature uniformity and pressure drop. The results show that the multi-channel serpentine flow field significantly improves the temperature distribution uniformity of the cooling plate while maintaining the same pressure drop of the cooling water compared to the normal serpentine flow field.

It can be seen that the temperature distribution inside the cell is determined by heat generation and transfer. Maximum temperature, temperature distribution, and pressure drop are commonly used as evaluation parameters to assess the performance of flow fields with different structures. Additionally, the temperature uniformity index (IUT) is commonly used to analyze the heat transfer performance of the flow field. Rahgoshay et al. [45] simulated the traditional serpentine flow field and parallel flow field using physical parameters such as pressure drop, minimum temperature gradient, maximum temperature gradient, and IUT. Under the same working conditions, the maximum temperature ratio of serpentine flow field to parallel flow field is 1.0028, and the IUT of serpentine flow field is 24% better than that of parallel flow field. Deng et al. [46] developed CFD models for parallel flow field, serpentine flow field, point flow field and wavy flow field, and used numerical simulation to analyze the heat transfer performance of each flow field. They introduced the IUT to evaluate the performance of the flow fields. Results indicated that the average temperature and IUT of the wavy flow field are 2.22% and 37.97% lower than those of the parallel flow field, respectively.

Scholars have found that the performance of fuel cells can be improved by optimizing the flow field structure. Wilberforce et al. [33], Xiong et al. [47], and Liu et al. [48] had conducted detailed summary of the structure and performance of the bipolar plate flow field all of which illustrate the effectiveness of these measures. In addition, this paper also makes some supplements and improvements to the relevant study in recent years, as shown in Table 1.

3.3.2. Unveiling water transfer mechanism and influential factors within PEMFC

3.3.2.1. Water transport pathways within PEMFC. The internal water transport and balance mechanisms of PEMFC is shown in Fig. 4. As mentioned above, the moisture inside the PEMFC mainly comes from the humidification of the reaction gas and the by-products of the electrochemical reaction. Under the action of external force, water flows through the CL and the GDL into the gas flow channel. With the flow of reaction gas, the liquid water is discharged from the fuel cell.

Dissolved water primarily undergoes transportation within the membrane through mechanisms such as electroosmotic drag, back diffusion, and convection [65]. The electro-osmotic drag coefficient can be obtained in-situ testing [66] or ex-situ testing [67], which involve

conducting water balance measurements under operating conditions or in H₂/H₂ mode. As shown in Eq. (17), the electroosmotic coefficient, ξ , defined as the number of water molecules carried across the membrane with each H⁺ [68].

$$\xi = \frac{N_{\text{H}_2\text{O}}}{N_{\text{H}^+}} = \frac{-\frac{\sigma_s}{F} \nabla \phi - \left(\alpha + \frac{\sigma_s^2}{F^2} \right) \nabla \mu_{\text{H}_2\text{O}}}{-\sigma \nabla \phi - \frac{\sigma_s}{F} \nabla \mu_{\text{H}_2\text{O}}} \quad (17)$$

Where $\mu_{\text{H}_2\text{O}}$ is the chemical potential of H₂O (J/mol), α is the transport coefficient (mol²·J⁻¹·cm⁻¹·s⁻¹), ϕ is the potential (V).

Springer et al. [69] corrected the experimental data and applied the linear relationship between ξ and λ to the modeling of PEMFCs, which has been widely used:

$$\xi = \frac{2.5\lambda}{22} \quad (18)$$

Due to the concentration gradient from the cathode to the anode, some of this water diffuses towards the anode. Additionally, when a pressure difference exists between the cathode and the anode, water can flow from one side of the membrane to the other. The diffusivity and hydraulic permeability of water can be calculated using the following formulas [70]:

$$N_{\text{H}_2\text{O,diff}} = -D(\lambda) \frac{\Delta c}{\Delta z} \quad (19)$$

$$N_{\text{H}_2\text{O,hyd}} = \kappa_{\text{hyd}}(\lambda) \frac{\Delta p}{\Delta z} \quad (20)$$

Where $D(\lambda)$ is the diffusion coefficient in ionomer of water content λ , $\frac{\Delta c}{\Delta z}$ is a water concentration gradient along the z-direction of membrane thickness, $\kappa_{\text{hyd}}(\lambda)$ is the hydraulic permeability of the membrane, and $\frac{\Delta p}{\Delta z}$ is the pressure gradient along z.

Diffusion, convection and capillary effects are the primary transport mechanisms governing the movement of water within the GDL [71]. The relationship between capillary force p_c and liquid water saturation s is [72]:

$$p_c = \sigma \cos \theta \left(\frac{\epsilon}{\tau} \right)^{0.5} J(s) \quad (21)$$







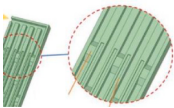

$$J(s) = \begin{cases} 1.42(1-s) - 2.12(1-s)^2 + 1.26(1-s)^3 & \theta < 90^\circ \\ 1.42s - 2.12s^2 + 1.26s^3 & \theta > 90^\circ \end{cases}$$

Where σ is the surface tension (N), θ is the contact angle of GDL (°), ϵ is the GDL porosity, τ is the GDL permeability.

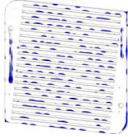
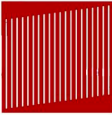
3.3.2.2. Unmasking factors governing water transfer within PEMFC. In order to optimize the performance of the assembly and the durability of the fuel cell, it is an important method to improve the water management to analyze and study the factors that affect the internal water transmission. Rahimi et al. [73] analyzed the flow field for seven different structures and simulated to verify the effect of the flow field on the current density, water distribution, and reactive gas mass fraction. Zhang et al. [74] developed a three-dimensional model in a PEMFC, and found that localized low temperatures could lead to the accumulation of liquid water in the anode, cathode channel, and porous electrode. Wang et al. [75] optimized the design of the cathode parallel flow field using sub-channels, and the results showed that the sub-channels and inlet positions had a substantial impact on reactant distribution, liquid water separation, and fuel cell performance.

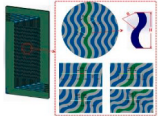
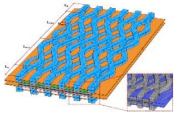
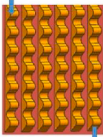

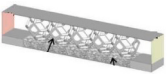
The microscopic performance parameters of GDL and MPL materials are the main factors affecting water distribution. Jiao et al. [76] conducted numerical studies on water transport in the form of vapor/liquid in the GDL. They found that the transport of water in liquid form is significantly influenced by the GDL design. Dokkar et al. [77] reported a three-dimensional simulation method for mass transport in a single area PEMFC. Through the analysis of the numerical simulation results, it was

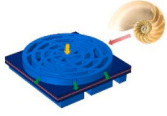
Table 1
Comparison of the performance of different structural flow fields.

Flow field type	Schematic diagram	Merit	Demerit	Reference
V-shaped flow field		<ol style="list-style-type: none"> 1. Pressure drop is lower 2. Uniform distribution of reactants 	<ol style="list-style-type: none"> 1. Poor uniformity of temperature distribution 	Rostami et al. [49]
Sub-channel flow field		<ol style="list-style-type: none"> 1. High current density 2. Timely discharge of liquid water 	<ol style="list-style-type: none"> 1. Complex structure and high precision requirement 2. Not commercially applied 	Zuo et al. [50]
Serpentine flow field		<ol style="list-style-type: none"> 1. Good uniformity of material transfer 2. Uniform current density distribution 3. Cell performance improvement 	<ol style="list-style-type: none"> 1. Large pressure drop 2. The water content decreases with the increase of current density 	Hamrang et al. [51]
Conical flow field		<ol style="list-style-type: none"> 1. Good diffusion of oxygen 2. Uniform distribution of saturated water 	<ol style="list-style-type: none"> 1. High parasitic power 2. High current density conditions, water discharge unfavorable 	Ashrafi et al. [52]
				Ghasabehi et al. [53]
Spiral baffle flow field		<ol style="list-style-type: none"> 1. Enhanced gas transmission 2. Increased power density 	<ol style="list-style-type: none"> 1. Increased gas flow disturbance 2. Still being developed by researchers experimentally 	Liu et al. [54]
S-shaped flow field		<ol style="list-style-type: none"> 1. Decrease the liquid water content in the cell 2. Enhance mass transfer capability 	<ol style="list-style-type: none"> 1. Large voltage drop, affecting cell performance 2. Processing difficulty 	He et al. [55]
Crossed wavy flow field		<ol style="list-style-type: none"> 1. Good cooling performance 2. High reactant transport capacity 3. High cell power 	<ol style="list-style-type: none"> 1. Poor distribution of local area reactants 2. Processing difficulty 	Yin et al. [56]
3D wavy flow field		<ol style="list-style-type: none"> 1. Adequate oxygen supply 2. Good water transmission performance 	<ol style="list-style-type: none"> 1. High flow resistance 2. High processing accuracy requirement 	Yan et al. [57]
Compressed nickel foam serpentine flow field		<ol style="list-style-type: none"> 1. Increased catalytic activity area 2. Improve gas diffusion uniformity 3. Internal impedance reduction 	<ol style="list-style-type: none"> 1. Complex preparation process 2. Differences in mass density 	Liu et al. [58]
Metal-foam flow field		<ol style="list-style-type: none"> 1. Uniform current density distribution 2. Simple manufacturing process 	<ol style="list-style-type: none"> 1. Vulnerable to corrosion 2. Large pressure drop 	Suo et al. [59]
				Kang et al. [60]
Spiral bionic flow field		<ol style="list-style-type: none"> 1. Uniform distribution of reactants 2. Better water removal 3. Better cell performance 	<ol style="list-style-type: none"> 1. High pressure loss 2. High processing difficulty 3. Complex structure, the corner is easy to form a pool of water 	Li et al. [61]

(continued on next page)

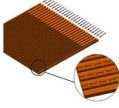
Table 1 (continued)

Flow field type	Schematic diagram	Merit	Demerit	Reference
Fishbone biomimetic flow field		<ol style="list-style-type: none"> 1. Improve quality transmission 2. Strong water removal ability 	<ol style="list-style-type: none"> 1. Power density distribution problem 2. Contact resistance exists 	Wang et al. [62]
Leaf-like bionic flow field		<ol style="list-style-type: none"> 1. Low pressure drop in the flow channel 2. High fuel cell output power 	<ol style="list-style-type: none"> 1. Oxygen starvation in localized areas 2. Processing difficulty 	Xia et al. [63]

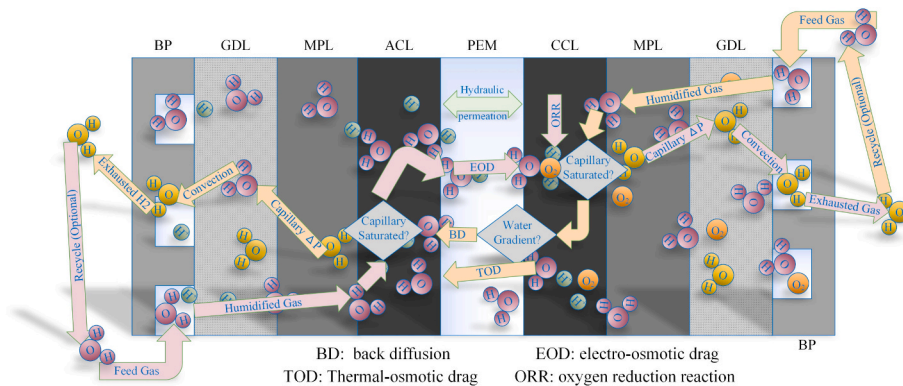

Fig. 4. Water transport and balance mechanisms in a typical PEMFC [64].

found that the water vapor was mainly concentrated in the GDL. Yang et al. [78] studied the water transport mechanism and local water distribution of open cathode PEMFC using local current measurement and electrochemical methods. When the current density is $<200 \text{ mA/cm}^2$, the PEM will be partially dehydrated, and the water distribution is very nonuniform. When the current density is larger than 700 mA/cm^2 , liquid water begins to accumulate in the GDL and CL.

Studying the material properties from the microscopic perspective can obtain the macroscopic performance parameters. Zhu et al. [79] proposed the design principle of the optimal thickness of the cathode GDL of PEMFC based on the balance of cell performance under the conditions of steady state and load change. The results showed that the best choice of cathode GDL thickness should balance the steady-state and transient performance, and the best cathode thickness is $100 \mu\text{m}$. Göbel et al. [80] used synchrotron radiation and scanning electron microscopy combined with focused ion beam serial sectioning to obtain three-dimensional images of GDL, which used to study the influence of its structural characteristics on water distribution. Carcadea et al. [81] studied the influence of GDL and microporous layer (MPL) on the performance of PEMFC by using numerical models. The results showed that the addition of MPL in GDL is helpful to the humidification of electrolyte membrane, thereby improving the overall performance of fuel cell.

The MPL is situated between the GDL and the CL in a fuel cell. It consists of a thin coating ($10\text{--}100 \mu\text{m}$) of carbon particles and hydrophobic agents applied to the surface of the GDL using spraying technology [82,83]. As shown in Fig. 5 (a), the presence of the MPL enhances the water management performance of fuel cells, facilitating the transfer of internal water and consequently improving the external power output. On the cathode side, the MPL reduces the transport flux of liquid water from the cathode CL to the cathode GDL, as well as the net water flux across the membrane from the anode side to the cathode side, as depicted in Fig. 5 (b). Nanadegani et al. [84] observed, through numerical simulations, that the addition of an extra MPL layer between the GDL and CL resulted in a discontinuity in liquid saturation at their interface due to differences in wetting performance between the two layers. Furthermore, thinner MPL thickness and higher porosity lead to improved cell performance. As shown in Fig. 5 (c), it can be seen that in

fuel cells with MPL, the water content inside the cathode side GDL has been significantly decreases, which will be conducive to the transmission of reactive gas. In summary, the further research is needed on the performance of MPL in water management to explore reasonable solutions to meet design requirements.

The flow field of the bipolar plate serves as the internal channel for the transmission of liquid and gaseous water, and improper structural design can lead to liquid water accumulation within the fuel cell. The thickness, porosity, and permeability of the GDL and MPL play a vital role in regulating the internal distribution of water and ensuring its uniformity. Through numerical simulations and experimental studies, optimizing the structural design of the GDL and MPL has been shown to enhance internal water diffusion. The further research should focus on developing strategies to effectively manage water within the fuel cell system, addressing issues such as water distribution, diffusion, and overall system performance.

3.4. Revolutionizing thermal management systems for optimal PEMFC performance

The thermal management system plays a crucial role in maintaining a stable operating temperature and improving the operating environment of the PEMFC. Uncontrolled thermal management can lead to the appearance of localized hot spots in the CL, which will intensify the permeation of hydrogen from the anode to the cathode [86–88]. When hydrogen is catalytically burned at the cathode, it produces thermal stress on the PEM, leading to geometric deformation of the membrane and accelerating its attenuation. Thus, this section provides a summary and review of the thermal management system's architecture, control strategy, and high-power heat dissipation.

3.4.1. Confronting the high-power heat dissipation challenge in PEMFC

With the development of research technologies, the power density has been increasing from 1.6 kW/L to 5.4 kW/L of the PEMFC [89]. Several researchers put forward a new cooling technology scheme from the perspectives of cooling mode, flow channel structure and coolant. It provides technical support for the application and promotion of high-

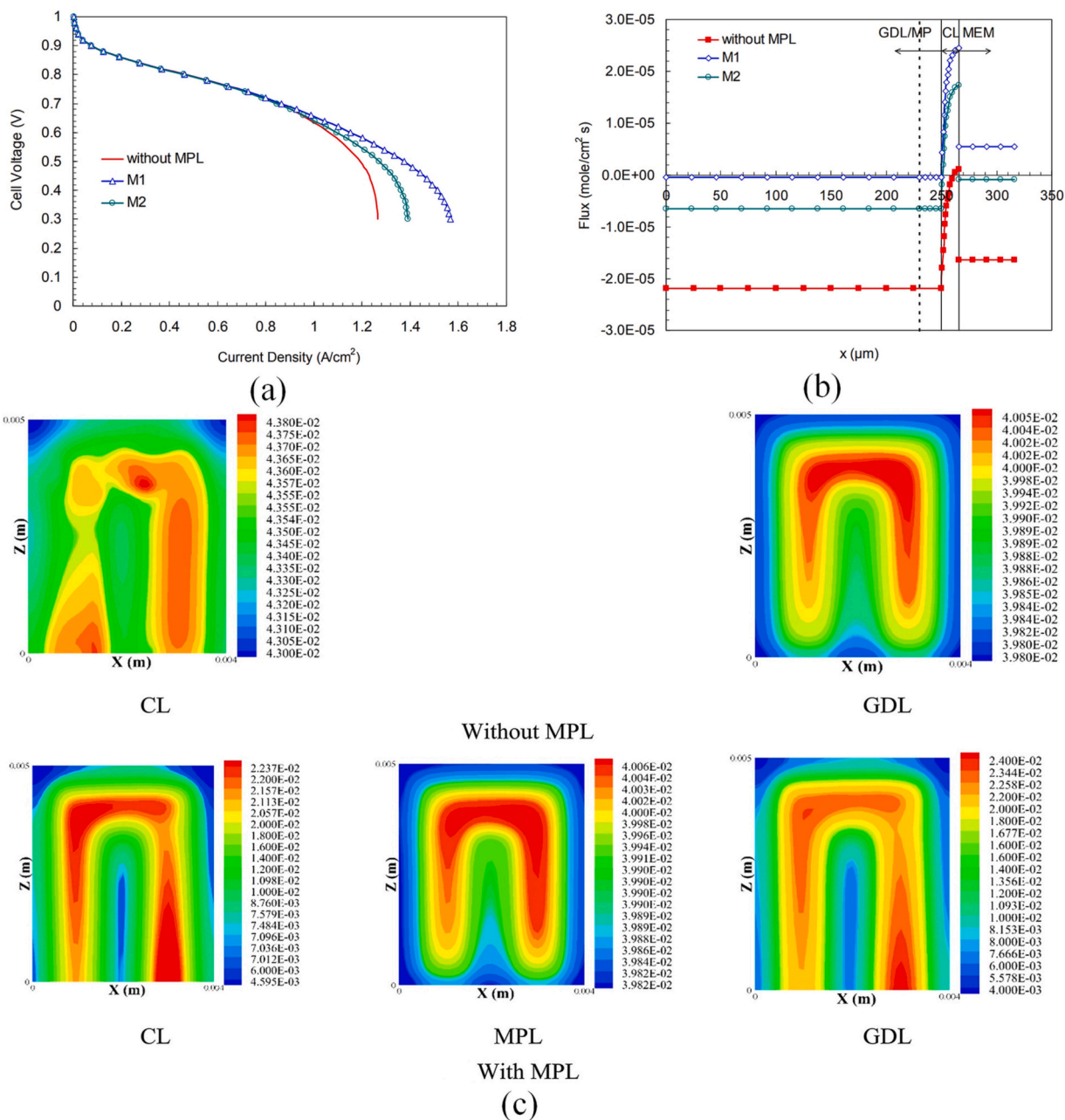

Fig. 5. (a) The influence of MPL on the polarization curve of fuel cell [85]; (b) Water fluxes in the simulated domain at 0.6 V [85]; (c) Contours of water mass fraction at the cathode side ($T = 60\text{ }^{\circ}\text{C}$, $\text{RH} = 100\%$, $V = 0.6\text{ V}$) [84].

power PEMFC. For instance, Afshari et al. [90] studied the influence of coolant channel shape on the cooling performance of water-cooled PEMFC through three-dimensional numerical simulation. The results showed that the zigzag channel can improve the cooling performance by reducing the maximum surface temperature and surface temperature difference.

Phase change cooling utilizes the latent heat of the coolant to dissipate heat from the fuel cell through evaporation or boiling [21], as confirmed by Yan et al. [89] through analysis and study of the mathematical model of phase change heat transfer. Perry et al. [91] employed water evaporation to absorb heat, thereby reducing cell temperature, and utilized water vapor to humidify the reaction gas. The heat pipe transfers heat from the fuel cell by leveraging the latent heat of the working fluid, while consuming low or no parasitic power. Clement and Wang [92] examined the use of pulsating heat pipe in thermal management of fuel cell, which can activate fuel cell with an area of up to

200 cm², and has a heat dissipation capacity is between 100 W and 120 W. Atyabi et al. [93] used Simulink to simulate and analyze the heat pipe model, with results indicating that heat pipe cooling enhances cell performance and reduces parasitic power in fuel cell systems.

In addition, some researchers generate nanofluids by dispersing non-metallic tiny metals or particles into the cooling liquid. The use of nanofluids has been shown through analysis to improve heat transfer efficiency and contribute to reducing the size of the thermal management system [94]. Arear et al. [95] developed and validated a MATLAB simulation model to investigate the cooling process and its impact on PEMFC using nanofluids as coolant. Islam et al. [96] used ZnO nanofluid as the coolant, and found that the ZnO nanofluid with a volume concentration of 0.5% can be used in the PEMFC cooling system without affecting the system performance. Zakaria et al. [97] used Al₂O₃ nano fluid as the cooling liquid for PEMFC, and found that only adding Al₂O₃ with a volume concentration of 0.5% in the water-based fluid could

increase the heat transfer rate by 187%.

Due to the space limitations, it is impossible to indefinitely increase the volume of the heat sink to meet the heat dissipation requirements of high-power applications based on the thermal management system. Therefore, more efficient methods are required to solve the problem of high-power heat dissipation. The research on the internal heat distribution and transfer is helpful to improve the efficiency of the fuel cell system. Although technologies such as phase change materials, heat pipes, and new coolants have been developed, there are still some technical drawbacks. Further solutions are required to address the practical application problems that exist in commercial applications.

3.4.2. Orchestrating stability: strategic approaches to thermal management control

The traditional PID algorithm and control structure are simple, making it widely used in fuel cell thermal management systems. Xing et al. [98] focused on the temperature control of PEMFC by regulating the cooling water flow and proposed a PID control method that can effectively regulate the cell temperature to about 350 K.

Conventional PID control strategies have some shortcomings, which have prompted researchers to propose new control strategies based on PID control theory to optimize control systems design. Damour et al. [99] proposed a self-tuning PID control strategy based on the artificial neural network model. The experimental results demonstrated that the control strategy has good performance in terms of tracking accuracy of the set point and robustness to model mismatch. Chen et al. [100] proposed a dynamic management controller based on model predictive control (MPC) for the management of temperature and voltage of PEMFC. They found that the MPC controller significantly reduced the response time and overshoot.

Based on the fuzzy control theory, some researchers analyzed and studied the control strategy of thermal and water management of PEMFC, and carried out relevant research and verification. Wang et al. [101] used Matlab/Simulink to establish the fuzzy control rules to regulate the temperature of PEMFC. Zou and Kim [102] designed a fuzzy controller and applied it to the cooling water pump control of the 5 kW water-cooled PEMFC thermal management system. The performance comparison with on/off controller, state feedback controller and PID controller showed that the controller is effective in fuel cell temperature control. Chen et al. [103] proposed a multi-input and multi-output fuzzy control method to study and analyze the dynamic performance of the temperature and humidity transient cooperative control under the disturbances of load current and operating parameters. The results show that the control method has faster response speed and better control performance. Xiong et al. [104] used the multi-input and multi-output fuzzy control theory to control the temperature and humidity of the cell. The results showed that the maximum temperature of the cell can be reduced by 5 °C and the output power can be increased by 5.8% on average.

With the development of intelligent control strategies, many researchers have combined different mathematical algorithms to develop intelligent and efficient control strategies that can respond quickly to changes in system dynamics. Wu et al. [105] proposed an adaptive control strategy, and verified the accuracy of the control strategy by simulation and experiment. Han et al. [106] designed a feedback controller including model reference adaptive control to solve the uncertainty of PEMFC and performed robust control on the inlet temperature of cell and coolant. Huang et al. [107] proposed an adaptive control strategy and the stability and convergence of the closed-loop system based on the analysis of Lyapunov method. The simulation showed that compared with proportional integral control, this control strategy can meet all control objectives and improve the control performance. Chatrattanawet et al. [108] proposed MPC for PEMFC control and off-line robust model predictive control based on linear time-varying model. The research results showed that MPC and robust MPC have achieved ideal results, and the robust MPC control can ensure the

stability of PEMFC.

In conclusion, the thermal management system of PEMFC has the characteristics of multivariable and strong coupling, and its control strategy has the characteristics of hysteresis and nonlinearity. A comparison of the performance of different control strategies is shown in Table 2. Therefore, to ensure the stable operation of the thermal management system, it is necessary to investigate the causes of the thermal management system out of control.

4. Transformative strategies for elevating thermal management efficiency

Although PEMFC have high power generation efficiency, they generate a significant amount of waste heat. The waste heat recovery technology can be used to reuse this heat energy and effectively improve the overall energy efficiency of PEMFC. One way to achieve this is by supplying the fuel cell system for internal use, such as preheating reaction gas, as shown in Fig. 6. Another way is to incorporate it into cogeneration systems [36]. In recent years, numerous researchers have conducted extensive studies on recovery and utilization of waste heat from PEMFC, achieving certain results that can enhance the comprehensive energy efficiency of these fuel cell.

4.1. Innovating waste heat recovery systems and their characteristics

Recovering and reusing this heat can improve the overall energy efficiency of the fuel cell system. However, this waste heat recovery and utilization can also impact the stability of the thermal management system and overall system operation. Han et al. [110] integrated an elastic cooler into the PEMFC thermal management system to collect waste heat and achieve the purpose of cooling PEMFC. A parametric study was conducted to reveal the relationship between operating conditions and parameters such as operating temperature, operating pressure and ambient temperature. Sun et al. [111] studied the waste heat recovery system of a fuel cell vehicle, developing a waste heat exchange rate model and an energy consumption model for the system. The study examined the effects of parameter variables on system energy

Table 2
Comparison of different control strategies.

Strategy	Merit	Demerit
PID control	1. Easy-to-use 2. Low-cost logic	1. Poor control of nonlinear systems
Self-tuning PID control	1. Little dependence on the model 2. Improved control accuracy	1. Difficulty in analyzing system performance theory 2. Limited adaptability to drastic changes
Multi loop PID control	1. Better control of complex systems 2. Better disturbance rejection	1. Delay and lag 2. Potential instability 3. Communication complexity
Sliding mode control	1. Robustness against parametric uncertainties 2. Fast response 3. Insensitivity to initial conditions	1. Chattering may occur 2. Sensitivity to parameter variations 3. Design complexity
Model predictive control	1. Multivariate can be handled efficiently 2. Handle various types of constraints	1. Higher computing needs 2. Sensitivity to model errors 3. Limited stability guarantees
Fuzzy control	1. Adaptation to nonlinear systems 2. Less sensitive to inaccuracies	1. Computational complexity 2. Subjectivity in rule design
Neural network control	1. Efficiently handle highly nonlinear systems 2. Highly adaptive 3. High-dimensional control	1. High data requirements 2. Computationally intensive 3. Long training time

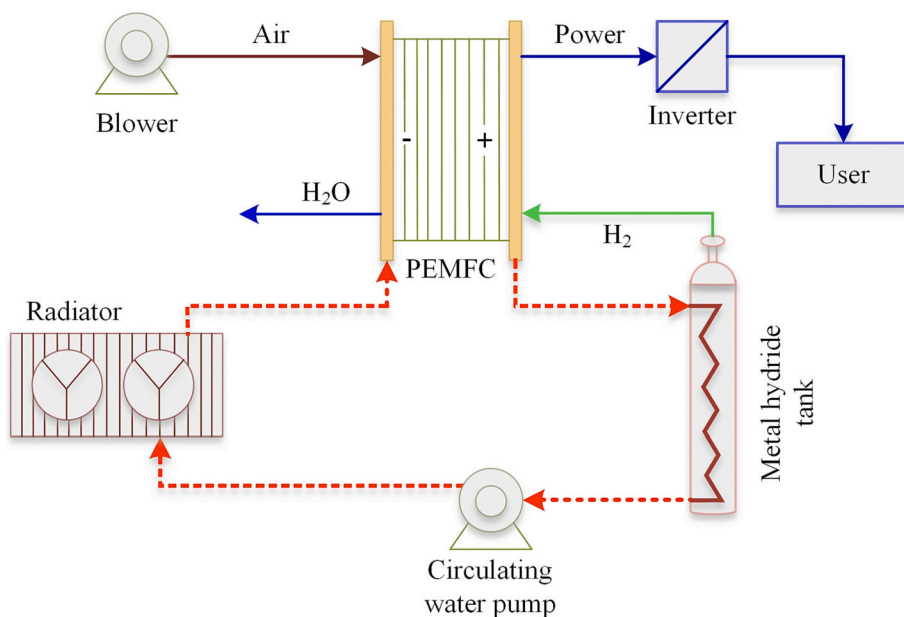

Fig. 6. Thermal coupling of liquid-cooled PEMFC and MH tank [109].

consumption and waste heat exchange rate at low temperatures. Mohamed et al. [112] preheated the hydrogen supply system with the waste heat from the PEMFC, but found that the waste heat utilization rate was only 3% ~ 6% due to the small flow rate of hydrogen. Li et al. [113] evaluated a proposed waste heat recovery system from the perspective of thermodynamics and exergy economics. They found that adjusting the operation parameters increased the available heat provided to the carriage from 933 W to 23,971 W.

The above studies demonstrate that waste heat recovery and utilization technology can improve the energy utilization efficiency of the fuel cell system to a certain extent, but it can also increase the complexity of the thermal management system and affect system stability. Further investigation into the relationship between the waste heat recovery system and the thermal management system is necessary to

explore rationalization options for their commercial application.

4.2. Harnessing thermoelectric power for quantum leap in waste heat utilization

With the rapid development of semiconductor materials, thermoelectric generators have emerged as a promising technology for waste heat recovery. By leveraging the principles of thermoelectric generation, these generators can convert heat energy into electricity, making them an ideal solution for capturing the waste heat generated by PEMFC [114], as shown in Fig. 7. To maximize the potential of thermoelectric generators in PEMFC waste heat recovery, researchers have conducted a range of studies exploring the system’s thermodynamic performance. For example, Cai et al. [115] comprehensively analyzed the

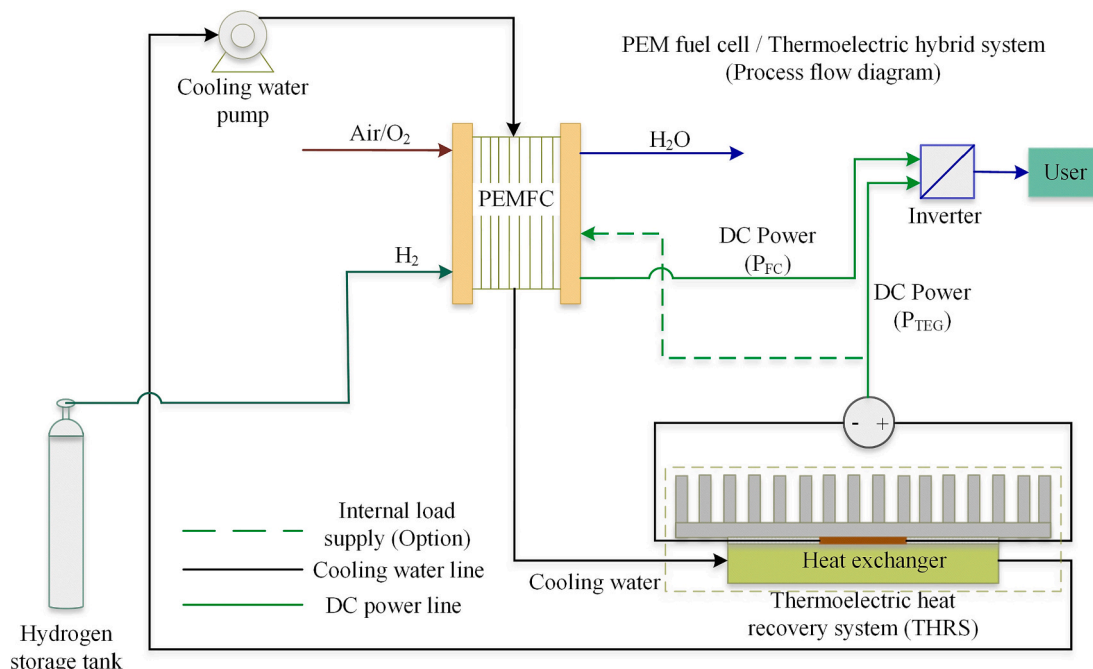

Fig. 7. Process flow diagram of PEMFC / TEG hybrid system [117].

performance of a fuel cell thermoelectric hybrid system using both thermoelectric cooling and thermoelectric generator models. This study aimed to investigate the energy conversion potential of the system's electrochemical and thermoelectric coupling processes. Similarly, Pourrahmani et al. [116] developed module and CFD thermal models of PEMFC stacks and thermoelectric generator heat exchangers, respectively, to simulate the operation and performance of both systems. The results showed that thermoelectric generators can improve the overall efficiency of the fuel cell system by capturing waste heat.

Other researchers have proposed and tested innovative methods for recovering waste heat from PEMFC. For example, Saufi et al. [118] developed an energy recovery system that combined thermoelectric generators, heat pipes, and radiators to capture ultra-low-temperature waste heat. Meanwhile, Alam et al. [119] explored the use of thermoelectric generators and metal hydride tanks to recover waste heat from PEMFC, developing a theoretical model to predict the dynamic performance of the system. The experimental results showed that their waste heat recovery method was more effective than natural cooling or fan cooling of the cold and hot sides of the thermoelectric generator.

Overall, these studies demonstrate the potential of thermoelectric generators for waste heat recovery and their ability to increase the efficiency of PEMFC systems. However, further research is needed to optimize the design and operation of these systems to ensure their stability and reliability in commercial applications.

4.3. Propelling forward: integrating advanced heat pump systems for enhanced thermal control

The integration system of heat pumps and PEMFC presents unique advantages for waste heat recovery and utilization, meeting heating demands while also capitalizing on waste heat for improved energy efficiency, as depicted in Fig. 8. Liu et al. [120] proposed an ammonia-water absorption compression heat pump system that achieved a coefficient of performance of 5.49 and exergy efficiency of 27.62% according to simulation results. He et al. [121] investigated two waste heat recovery and utilization methods, organic Rankine cycles and combined organic Rankine cycles with heat pumps, with the latter achieving a thermal efficiency of 4.73%, a 17% increase over the ORC system's

4.03% thermal efficiency. Lee et al. [122] assessed the heating performance of cold source heat pumps with fuel cell stacks and electric equipment's waste heat by varying the inlet air temperature, compressor speed, coolant temperature, and coolant volume flow. Alijanpour et al. [123] studied the waste heat recovery technology of a 1180 kW system of PEMFC, identifying a method for recovering low-temperature waste heat from the PEM via regenerated organic Rankine cycles. Zhao et al. [124] developed a new vehicle integrated thermal management system and heat pump system, demonstrating that waste heat reuse in this system improves cabin thermal comfort, energy efficiency, and operating costs compared to PTC heating.

While waste heat recovery technology can enhance fuel cell performance and energy conversion efficiency to some extent, its utility is limited by the available temperature of the waste heat, resulting in low waste heat utilization efficiency of the system. Additionally, the application and development of heat pump systems in PEMFC systems still face certain drawbacks from an economic standpoint, with complex structures and high costs presenting challenges for wider adoption.

4.4. Efficient solutions for thermal management of cold start

The temperature during the cold start of a fuel cell serves as a critical indicator influencing its cold start performance. The objective of the cold start is to elevate the battery temperature above 0 °C before the cathode catalyst layer pores become obstructed by ice. The choice of the cold start control strategy significantly impacts internal temperature variations. Montaner Ríos et al. [126] extensively investigated both passive and active strategies, utilizing a 4 kW PEMFC stack with temperature ranges from 0 °C to -30 °C. Their findings reveal the success of the passive strategy in cold starting, particularly at -30 °C. Yang et al. [127] proposed an efficient cold-start strategy amalgamating the advantages of self-starting and coolant heating, enabling the self-starting of a fuel cell electric stack from -20 °C within 30s. The voltage consistency during cold start, closely linked to cold start performance, is influenced by startup temperature and heating power. Pan et al. [128] introduced an adaptive cold-start strategy based on maximum power tracking, achieving a high and stable output performance for PEMFC cold start with a current load of 27 A, confirming the strategy's

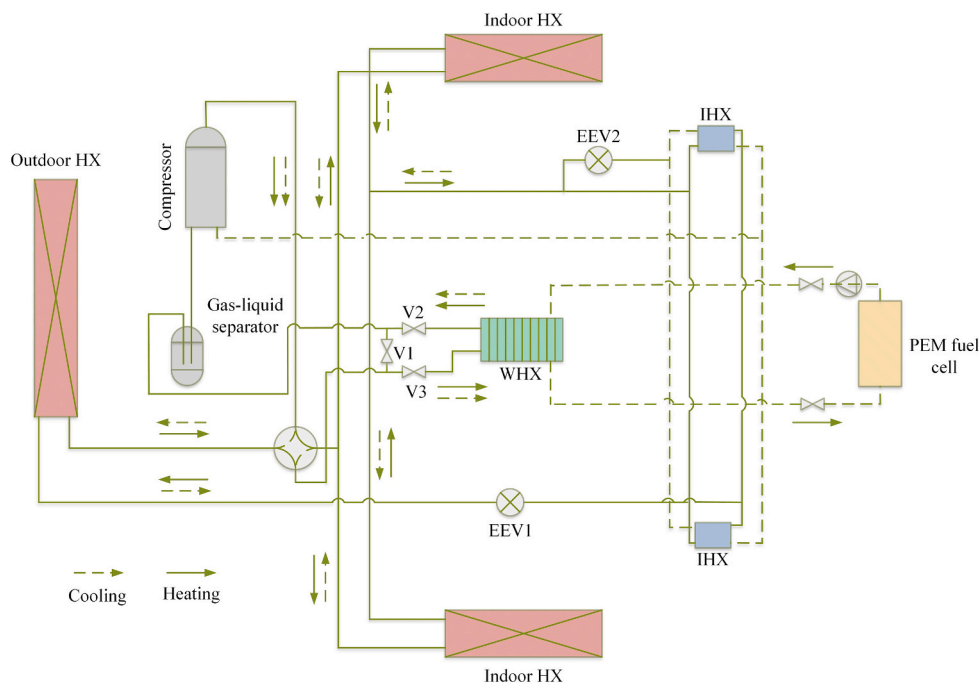

Fig. 8. The flowchart prototype of the heat pump system with waste heat exchanger [125].

feasibility. Chang et al. [129] observed successful stack initiation at $-5\text{ }^{\circ}\text{C}$ without external heating, but below $-10\text{ }^{\circ}\text{C}$, a cold start becomes impractical unless the end plates receive a specified amount of power. Qin et al. [130] developed a quasi-two-dimensional dynamic model, indicating that the circulating coolant heating method is most effective for power reactor cold start at $-40\text{ }^{\circ}\text{C}$. Cao et al. [131] proposed a multistage cold-start strategy for heating power and current, achieving synergistic control of positive temperature coefficient (PTC) heaters and electric stacks. This strategy reduces startup time by 115.4 s compared to other control strategies.

The comprehensive analysis above shows that an efficient and stable control strategy is the key to ensure its start-up process. Initially, the temperature of the fuel cell during the cold start phase emerges as a crucial factor influencing the startup procedure, serving to mitigate potential issues such as water icing resulting from electric pile operation. Additionally, optimizing the efficiency of the cold start phase entails a focus on minimizing the duration of the startup process.

5. Transformative strategies for elevating water management efficiency

Inadequate water management in PEMFC can lead to detrimental effects such as overflowing and dehydration, significantly impacting system efficiency and exacerbating performance degradation [132]. Improper water management not only shortens its service life, but also destabilizes the overall performance. Therefore, it is important to identify the key factors contributing to the instability of the internal water balance and to keep the water content within reasonable limits.

5.1. Pioneering advanced techniques for sustaining internal water balance

To maintain the internal water balance, various operating parameters must be adjusted, and their influences on the system must be carefully analyzed. Li et al. [133] investigated the effects of various cathode inlet humidity conditions on the system while subject to voltage step changes. Their findings the water content inside the fuel cell exhibits a gradual decrease over time during the operation within the 0–6 s timeframe. In contrast, during the 6–12 s timeframe, the water content gradually increases over time. This behavior can be attributed to the electrochemical reactions taking place within the fuel cell, gradually generating water.

The effect of cell operating temperature, current density and channel geometry on the water content of PEM was studied by Tran et al. [134]. The results showed that the water content of PEM decreased with the increase of current density and temperature, independent of the channel geometry. However, through modeling and simulation of the flow channel structure, Ying et al. [135] conducted a modeling and simulation study on the flow channel structure and found that in the region of high current density, a large amount of water is carried to the cathode by protons, and it is found that the transport of water in the membrane is affected by the channel geometry. Further research is necessary to fully understand the extent to which geometric channels influence the water content of the PEM. By identifying the key factors that impact the internal water balance, it will be possible to develop effective strategies to ensure stable and efficient fuel cell performance.

In addition, researchers have contributed significantly to the enhancement of water management performance from different aspects. Sarker et al. [136] developed a two-dimensional, two-phase, multi-physics model to simulate performance and gain fundamental insight into local water saturation and oxygen concentration. Fan et al. [137] and Zhang et al. [138] found high liquid water content in the CL at high current densities by building a three-dimensional (3D) model. By establishing a 3D model of PEMFC flow channel, Shen [139] and He et al. [140] studied the water transfer of the new 3D flow field and the cell's operation characteristics, revealing that the 3D flow field can effectively separate the liquid water in the reactant.

It is noteworthy that current physical models for water management-related studies are all based on homogeneous models, and the characteristics of heterogeneous models in water management simulation analysis require further investigation. Questions remain about how to keep the moisture content of the components within reasonable limits. Further research is necessary to explore the characteristics of its water management.

5.2. Navigating strategies for precise water content regulation

Improving the accuracy of water content model prediction can lead to higher overall energy utilization efficiency. A joint measurement between battery impedance and mass balance can establish the relationship between local water distribution and the electrochemical performance of the entire cell [141]. Wang et al. [24] proposed a comfort index to comprehensively evaluate the hydrothermal characteristics of PEMFC. The index includes the accumulation of cathode liquid water and the drying of the anode membrane as two basic factors to prevent flooding and the reduction of proton conductivity simultaneously. They found that lower water saturation pressure at low temperature makes water easier to condense, while the comfort index generally increases first and then decreases with an increase in temperature. Zhang et al. [142] established a model of water coagulation rate to study the change of water content and its impact on the performance of PEMFC. They found that the cooling water rate of the cathode channel is 1.05–1.55 times of that of the anode channel, and the water coagulation rate model can predict the change of water content and improve the accuracy of performance calculation from 9% to 31%. Zhang et al. [143] added a fluid volume model to the fuel cell model, and established and verified the accuracy of the two-dimensional multiphase fuel cell model by tracking the two-phase flow in the cathode channel. Their results showed that, when the water content is 10%, the average current density and the minimum current density decrease by 4.23% and 7.49%, respectively.

Quantitative analysis of water content can guide the adjustment of the internal operating environment. However, few studies have focused on the system-level water management process of PEMFC. In the dynamic process of the system, particularly during power-on, power-off, and load change, the operating conditions are constantly changing, increasing the complexity of the process exponentially. Therefore, a deeper investigation is needed to maintain the internal water management status.

5.3. Unlock efficient water management solutions for extreme environments

According to Benmouna et al. [144], it is known that membrane electrode water flooding accounts for 33% and electrolyte membrane bias drying accounts for 19%. This involves water management problems under extreme operating conditions are particularly important, such as cold start at low temperatures ($<0\text{ }^{\circ}\text{C}$) and high temperatures, where water freezing and water loss mainly occur. Therefore, the water management problem is one of the main factors affecting the operational performance and lifetime of fuel cells.

Low-temperature cold start of the fuel cell means that it can be successfully started in temperatures below $0\text{ }^{\circ}\text{C}$, and the internal temperature of the fuel cell can be rapidly increased to $70\text{--}80\text{ }^{\circ}\text{C}$ that can meet the normal operation of the system. To address the issue of water management during cold start, this part of the study has been investigated and analyzed in detail by Luo et al. [145] in 2018 and Chen et al. [12] in 2021. This paper adds to the research on fuel cell cold start in recent years. The decay of the component performance of a fuel cell affects its electrochemical reaction rate. Yang et al. [146] experimentally investigated the cold-start phase kinetics of a fuel cell and its degradation mechanism. Based on the local physical characterization, it was shown that the volumetric strain induced by the water/ice

transition leads to crack formation, Pt particle growth, and ionic agglomeration in the CL, which is the root cause of the frost degradation. Under cold start conditions, Li et al. [147] found that fuel cell with electrospun MPL generated electricity for a longer time, possibly due to better interfacial connection, which facilitated water removal from catalyst layer. On the basis of the experimental results, Chen et al. [148] carried out a theoretical study on the freezing onset probability to elucidate the freezing characteristics. The results show that the probability of water freezing increases abruptly with the increase of water subcooling in the GDL. Wang et al. [149] improved the cold start characteristics of PEFC by patterned wetting of its MPL and GDL. They found that dual H-MPL and H-GDL have the potential to achieve liquid exclusion and rapid water movement in membrane electrode components.

Increasing the operating temperature of fuel cells is one of the future directions. However, high cost and low durability due to insufficient performance of key materials such as electrocatalysts and membranes at high temperatures, as well as affecting the internal water content and its distribution, remain challenges that hinder the practical application of this technology [150]. The sensitivity of operating parameters has an important impact on water management, Liu et al. [151] found that in the low current density region, less water is produced by the reactor reaction, and the higher the operating temperature, the more water is removed, which ultimately leads to a degradation of the reactor performance. Kim et al. [152] investigated the effect of humidifiers on the operation of electric stacks. The results showed that when the dry start-up process was conducted at high temperature, the overall tendency was similar to that observed at low temperature. In addition, it was confirmed that the reaction at atmospheric pressure was ineffective compared with the low temperature start-up operation, because the water inside the fuel cell could evaporate easily. Yang et al. [78] investigated the effect of operating parameters on water management. On the one hand, when the current density is lower than 500 mA cm^{-2} , increasing the temperature and air flow rate decreases the cell performance because too much water is removed from the fuel cell, which leads to membrane dehydration. On the other hand, when the current density is higher than 600 mA cm^{-2} , increasing the cell temperature and air flow rate can improve the cell performance by removing excess water from the pores of the gas diffusion and catalyst layers. Zhou et al. [153] investigated the effect of localized heating on the performance of a PEFC by applying localized heating to three regions of the electrode, the fuel inlet region, the central region, and the outlet region, the latter of which showed the best performance (in the activation, ohmic, and mass-transfer-control zones, the output voltages were increased by 1.28, 2.17, and 2.46%, respectively, compared to that in the absence of localized heating).

In conclusion, the electrochemical performance and lifespan of fuel cells are profoundly influenced by water management. Addressing the prevention of ice formation during the cold start phase emerges as a crucial strategy to mitigate challenges associated with cold starts. While elevating the operating temperature of the fuel cell can enhance operational efficiency to a certain degree, it introduces new demands on the material properties of the membrane electrode assembly due to the excessively high operating temperatures. Therefore, a balanced approach must be pursued to optimize both water management and temperature control for the overall improvement of fuel cell performance and longevity.

6. Current limitations and future perspectives

This study delves into the intricacies of thermal and water management in PEMFCs, with particular attention on the challenges posed by high-power heat dissipation and water content optimization. Despite existing research endeavors in the field of PEMFCs, several hurdles and limitations still persist, affecting both technical feasibility and practical application.

- 1) **Strengthening Heat and Mass Transfer Coupling:** While the structural configuration of the flow field undeniably shapes heat and mass transfer in fuel cells, a significant research gap lies in comprehending the intertwined dynamics of these processes. Although existing studies have predominantly focused on the flow channel's impact on reactant gas distribution, temperature, and water, a more nuanced exploration of the interplay between heat and mass transfer holds the promise of further enhancing system performance.
- 2) **Elevating Stability of Intelligent Thermal Management Strategies:** The operational stability of intelligent thermal management strategies remains a pivotal frontier for successful commercial deployment. The intricacies of designing and executing a thermal management system wield a profound influence over PEMFC operability. Yet, the inherent complexity of the system presents a formidable challenge. While numerous studies have sought to formulate intelligent control strategies, substantial research is warranted to surmount the inherent obstacles, enabling widespread and robust commercial application.
- 3) **Navigating High-Power Heat Dissipation in Vehicular PEMFCs:** Addressing the challenge of high-power heat dissipation in vehicular PEMFCs remains an enigma awaiting resolution. As vehicular power demands escalate, modifications in fuel cell stack power become inevitable. However, spatial constraints confine the expansion of radiator volumes, demanding optimization of existing thermal management systems to meet the burgeoning heat dissipation requisites of high-power fuel cell stacks.
- 4) **Unlocking the Practical Viability of Waste Heat Recovery:** The realization of waste heat recovery's potential hinges on transcending significant barriers to practical implementation. Integration of waste heat recovery technology holds the promise of substantial gains in energy utilization efficiency. Highlighting the potential of heat pump systems in waste heat recovery is pivotal. Yet, cost constraints and utilization inefficiencies present hurdles to commercialization and widespread adoption. Developing an optimized waste heat recovery framework emerges as a crucial facet in propelling PEMFC technology and enhancing overall energy conversion efficiency.
- 5) **Addressing Uncertainties in Internal Water Content:** Clarifying the enigma of internal water content and its diverse states within PEMFCs requires dedicated research. Ascertaining the extent of membrane water conversion to liquid and gas states stands as a vital objective. The nature of water produced by the CL warrants exploration, as the prevalent notion implies membrane water under low current densities and liquid water under high current densities. Nevertheless, localized factors influence the actual state. Furthermore, the exploration of non-uniform distribution models needs to be further investigated and analyzed in future studies.
- 6) **Improved Water Management in Extreme Conditions:** Water and heat management in proton exchange membrane fuel cells presents a closely intertwined challenge. The critical factor influencing the initiation of the electric reactor is the cold start problem in low-temperature environments. This initial stage necessitates the application of heat to address the issue of icing. Subsequently, optimal operational conditions and a moderate temperature increase prove beneficial in augmenting the electrochemical reaction rate of the fuel cell. Nevertheless, an excessively high temperature can lead to water loss from the electrolyte membrane. Therefore, it is imperative to undertake extensive material modifications and research endeavors to address water management challenges in fuel cells, particularly in the contexts of cold starts and high-temperature operations.

7. Conclusions

Enhancing the durability of PEMFCs remains a paramount technical challenge, with its resolution critically influencing the operational lifespan of vital system components. The pursuit of effective thermal and water management serves as a linchpin in maintaining equilibrium

across water distribution and temperature within PEMFCs, mitigating the risks of flooding and localized overheating.

This paper systematically examines the recent strides made in PEMFC technology, providing a thorough assessment across various domains. Encompassing aspects such as flow channel modeling, thermal and water management, control strategies, waste heat recovery, and cold start, it highlights the extensive advancements in these areas. The integration of theoretical modeling, simulation analyses, and empirical investigations collectively showcases significant progress in both the development and application of PEMFCs. This comprehensive approach lays a solid groundwork for ongoing efforts in advancing technological maturity and widespread dissemination.

Furthermore, this study accentuates the nuanced challenges inherent in PEMFC thermal and water management. By pinpointing pivotal advancements and charting the trajectory for future research, it aims to galvanize further exploration. Crucially, it furnishes indispensable theoretical signposts for technology scholars and innovators.

The insights garnered from this research herald a new phase of PEMFC technology evolution, characterized by heightened efficiency, reliability, and sustainability. As we stride forth, these insights not only illuminate the path but also elevate the paradigm of possibility within the realm of clean energy technology.

CRediT authorship contribution statement

Zhenya Zhang: Writing – original draft, Methodology, Investigation, Funding acquisition, Formal analysis, Data curation, Conceptualization.
Jia Mao: Writing – original draft, Methodology, Investigation, Formal analysis.
Zhengxuan Liu: Writing – review & editing, Writing – original draft, Supervision, Methodology, Investigation, Formal analysis, Data curation, Conceptualization.

Declaration of competing interest

None.

Acknowledgments

This work was supported by the Doctoral Scientific Research Foundation of Zhengzhou University of Light Industry (Grant No. 2020BSJJ082).

References

- [1] Y. Zhou, Climate change adaptation with energy resilience in energy districts—a state-of-the-art review, *Energy. Build.* 279 (2023) 112649, <https://doi.org/10.1016/j.enbuild.2022.112649>.
- [2] X. Xu, Q. Zhou, D. Yu, The future of hydrogen energy: bio-hydrogen production technology, *Int J Hydrogen Energy* 47 (2022) 33677–33698, <https://doi.org/10.1016/j.ijhydene.2022.07.261>.
- [3] H. Blanco, J. Leaver, P.E. Dodds, R. Dickinson, G.D. García, D. Iribarren, A. Lind, C. Wang, J. Daneberg, M. Baumann, A taxonomy of models for investigating hydrogen energy systems, *Renew. Sust. Energy. Rev.* 167 (2022) 112698, <https://doi.org/10.1016/j.rser.2022.112698>.
- [4] L. Xu, C.D. Mueller, J. Li, M. Ouyang, Z. Hu, Multi-objective component sizing based on optimal energy management strategy of fuel cell electric vehicles, *Appl. Energy* 157 (2015) 664–674, <https://doi.org/10.1016/j.apenergy.2015.11.068>.
- [5] F. Dawood, M. Anda, G.M. Shafiullah, Hydrogen production for energy: an overview, *Int J Hydrogen Energy* 45 (2020) 3847–3869, <https://doi.org/10.1016/j.ijhydene.2019.12.059>.
- [6] S. Chugh, C. Chaudhari, K. Sonkar, A. Sharma, G.S. Kapur, S.S.V. Ramakumar, Experimental and modelling studies of low temperature PEMFC performance, *Int J Hydrogen Energy* 45 (2020) 8866–8874, <https://doi.org/10.1016/j.ijhydene.2020.01.019>.
- [7] Z. Wang, Z. Liu, L. Fan, Q. Du, K. Jiao, Application progress of small-scale proton exchange membrane fuel cell, *Energy Rev.* 2 (2023) 100017, <https://doi.org/10.1016/j.enrev.2023.100017>.
- [8] J.H. Wee, Applications of proton exchange membrane fuel cell systems, *Renew. Sust. Energy. Rev.* 11 (2007) 1720–1738, <https://doi.org/10.1016/j.rser.2006.01.005>.
- [9] W. Wu, C. Zhai, Z. Sui, Y. Sui, X. Luo, Proton exchange membrane fuel cell integrated with microchannel membrane-based absorption cooling for hydrogen vehicles, *Renew. Energy* 178 (2021) 560–573, <https://doi.org/10.1016/j.renene.2021.06.098>.
- [10] J. Zhang, B. Wang, J. Jin, S. Yang, G. Li, A review of the microporous layer in proton exchange membrane fuel cells: materials and structural designs based on water transport mechanism, *Renew. Sust. Energy. Rev.* 156 (2022) 111998, <https://doi.org/10.1016/j.rser.2021.111998>.
- [11] M. Zunita, A. Raizki, R. Aditya, I.G. Wenten, Proton exchange polyionic liquid-based membrane fuel cell applications, *Res. Eng. Des.* 16 (2022) 100653, <https://doi.org/10.1016/j.rineng.2022.100653>.
- [12] Q. Chen, G. Zhang, X. Zhang, C. Sun, K. Jiao, Y. Wang, Thermal management of polymer electrolyte membrane fuel cells: a review of cooling methods, material properties, and durability, *Appl. Energy* 286 (2021) 116496, <https://doi.org/10.1016/j.apenergy.2021.116496>.
- [13] X. Wang, Y. Ma, J. Gao, T. Li, G. Jiang, Z. Sun, Review on water management methods for proton exchange membrane fuel cells, *Int J Hydrogen Energy* 46 (2021) 12206–12229, <https://doi.org/10.1016/j.ijhydene.2020.06.211>.
- [14] T. Wilberforce, A.G. Olabi, I. Muhammad, A. Alaswad, E.T. Sayed, A.G. Abo-Khalil, H.M. Maghrabi, K. Elsaid, M.A. Abdelkareem, Recovery of waste heat from proton exchange membrane fuel cells – a review, *Int J Hydrogen Energy* (2022), <https://doi.org/10.1016/j.ijhydene.2022.08.069>.
- [15] S.G. Kandlikar, Z. Lu, Thermal management issues in a PEMFC stack – a brief review of current status, *Appl. Therm. Eng.* 29 (2009) 1276–1280, <https://doi.org/10.1016/j.applthermaleng.2008.05.009>.
- [16] J. Ramousse, O. Lottin, S. Didierjean, D. Maillet, Heat sources in proton exchange membrane (PEM) fuel cells, *J. Power Sources* 192 (2009) 435–441, <https://doi.org/10.1016/j.jpowsour.2009.03.038>.
- [17] L. Xiao, L. Zhu, C. Clökler, A. Grünzweig, F. Wilhelm, J. Scholta, R. Zeis, Z. Shen, M. Luo, P. Sui, Experimental validation of pore-scale models for gas diffusion layers, *J. Power Sources* 536 (2022) 231515, <https://doi.org/10.1016/j.jpowsour.2022.231515>.
- [18] H. Ju, C. Wang, S. Cleghorn, U. Beuscher, Nonisothermal modeling of polymer electrolyte fuel cells: I. Experimental validation, *J. Electrochem. Soc.* 152 (2005) A1645, <https://doi.org/10.1149/1.1943591>.
- [19] C. Wang, Fundamental Models for Fuel Cell Engineering, *Chem. Rev.* 104 (2004) 4727–4766, <https://doi.org/10.1021/cr020718s>.
- [20] R. Vetter, J.O. Schumacher, Free open reference implementation of a two-phase PEM fuel cell model, *Comput. Phys. Commun.* 234 (2019) 223–234, <https://doi.org/10.1021/cr020718s>.
- [21] G. Zhang, S.G. Kandlikar, A critical review of cooling techniques in proton exchange membrane fuel cell stacks, *Int J Hydrogen Energy* 37 (2012) 2412–2429, <https://doi.org/10.1016/j.ijhydene.2011.11.010>.
- [22] L. Liu, T. Liu, F. Ding, H. Zhang, J. Zheng, Y. Li, Exploration of the polarization curve for proton-exchange membrane fuel cells, *ACS Appl. Mater. Interfaces* 13 (2021) 58838–58847, <https://doi.org/10.1021/acsami.1c20289>.
- [23] P. Yang, Y. Wang, Z. Jin, Numerical simulation study on operation characteristics of PEMFC in low temperature environment, *J. Renew. Sustain. Energy.* 13 (2021) 014301, <https://doi.org/10.1063/5.0021429>.
- [24] R. Wang, G. Zhang, Z. Hou, K. Wang, Y. Zhao, K. Jiao, Comfort index evaluating the water and thermal characteristics of proton exchange membrane fuel cell, *Energy. Convers. Manag.* 185 (2019) 496–507, <https://doi.org/10.1016/j.enconman.2019.02.021>.
- [25] W. Olbrich, T. Kadyk, U. Sauter, M. Eikerling, Modeling of wetting phenomena in cathode catalyst layers for PEM fuel cells, *Electrochim. Acta* 431 (2022) 140850, <https://doi.org/10.1016/j.electacta.2022.140850>.
- [26] R. O'Hayre, D.M. Barnett, F.B. Prinz, The triple phase boundary: a mathematical model and experimental investigations for fuel cells, *J. Electrochem. Soc.* 152 (2005) A439, <https://doi.org/10.1149/1.1851054>.
- [27] M. Striednig, T.J. Schmidt, F.N. Büchi, A model based investigation of evaporative cooling for polymer electrolyte fuel cells—system level analysis, *J. Power Sources* 542 (2022) 231720, <https://doi.org/10.1016/j.jpowsour.2022.231720>.
- [28] M. Schröder, F. Becker, J. Kallo, C. Gentner, Optimal operating conditions of PEM fuel cells in commercial aircraft, *Int J Hydrogen Energy* 46 (2021) 33218–33240, <https://doi.org/10.1016/j.ijhydene.2021.07.099>.
- [29] G. Flipo, C. Josset, G. Giacoppo, G. Squadrito, B. Auvity, J. Bellettre, Eruptive water transport in PEMFC: a single-drop capillary model, *Int J Hydrogen Energy* 40 (2015) 14667–14675, <https://doi.org/10.1016/j.ijhydene.2015.06.082>.
- [30] R. Marek, J. Straub, Analysis of the evaporation coefficient and the condensation coefficient of water, *Int. J. Heat Mass Transf.* 44 (2001) 39–53, [https://doi.org/10.1016/S0017-9310\(00\)00086-7](https://doi.org/10.1016/S0017-9310(00)00086-7).
- [31] H. Askaripour, Effect of operating conditions on the performance of a PEM fuel cell, *Int. J. Heat Mass Transf.* 144 (2019) 118705, <https://doi.org/10.1016/j.ijheatmasstransfer.2019.118705>.
- [32] J. Zhou, S. Shukla, A. Putz, M. Secanell, Analysis of the role of the microporous layer in improving polymer electrolyte fuel cell performance, *Electrochim. Acta* 268 (2018) 366–382, <https://doi.org/10.1016/j.electacta.2018.02.100>.
- [33] T. Wilberforce, Z. El Hassan, E. Ogungbemi, O. Ijaodola, F.N. Khatib, A. Durrant, J. Thompson, A. Baroutaji, A.G. Olabi, A comprehensive study of the effect of bipolar plate (BP) geometry design on the performance of proton exchange membrane (PEM) fuel cells, *Renew. Sust. Energy. Rev.* 111 (2019) 236–260, <https://doi.org/10.1016/j.rser.2019.04.081>.
- [34] B. Wang, K. Wu, Z. Yang, K. Jiao, A quasi-2D transient model of proton exchange membrane fuel cell with anode recirculation, *Energy. Convers. Manag.* 171 (2018) 1463–1475, <https://doi.org/10.1016/j.enconman.2018.06.091>.
- [35] B. Shabani, J. Andrews, S. Watkins, Energy and cost analysis of a solar-hydrogen combined heat and power system for remote power supply using a computer

- simulation, *Sol. Energy* 84 (2010) 144–155, <https://doi.org/10.1016/j.solener.2009.10.020>.
- [36] A. Baroutaji, A. Arjunan, M. Ramadan, J. Robinson, A. Alaswad, M. A. Abdelkareem, A.G. Olabi, Advancements and prospects of thermal management and waste heat recovery of PEMFC, *Int. J. Therm.* 9 (2021) 100064, <https://doi.org/10.1016/j.ijft.2021.100064>.
- [37] S.G. Kandlikar, Z. Lu, Fundamental research needs in combined water and thermal management within a proton exchange membrane fuel cell stack under normal and cold-start conditions, *J. Fuel Cell. Sci. Tech.* (2009) 6, <https://doi.org/10.1115/1.3008043>.
- [38] X. Zhao, Y. Li, Z. Liu, Q. Li, W. Chen, Thermal management system modeling of a water-cooled proton exchange membrane fuel cell, *Int J Hydrogen Energy* 40 (2015) 3048–3056, <https://doi.org/10.1016/j.ijhydene.2014.12.026>.
- [39] X. Yu, B. Zhou, A. Sobiesiak, Water and thermal management for Ballard PEM fuel cell stack, *J. Power Sources* 147 (2005) 184–195, <https://doi.org/10.1016/j.jpowsour.2005.01.030>.
- [40] H. He, S. Quan, F. Sun, Y. Wang, Model predictive control with lifetime constraints based energy management strategy for proton exchange membrane fuel cell hybrid power systems, *IEEE Trans. Ind. Electron.* 67 (2020) 9012–9023, <https://doi.org/10.1109/TIE.2020.2977574>.
- [41] B. Shabani, J. Andrews, An experimental investigation of a PEM fuel cell to supply both heat and power in a solar-hydrogen RAPS system, *Int J Hydrogen Energy* 36 (2011) 5442–5452, <https://doi.org/10.1016/j.ijhydene.2011.02.003>.
- [42] M. Ghasemi, A. Ramiar, A.A. Ranjbar, S.M. Rahgoshay, A numerical study on thermal analysis and cooling flow fields effect on PEMFC performance, *Int J Hydrogen Energy* 42 (2017) 24319–24337, <https://doi.org/10.1016/j.ijhydene.2017.08.036>.
- [43] C. Chen, C. Wang, X. Wang, Z. Zhang, Study on the performance and characteristics of fuel cell coupling cathode channel with cooling channel, *Int J Hydrogen Energy* 46 (2021) 27675–27686, <https://doi.org/10.1016/j.ijhydene.2021.05.212>.
- [44] S.M. Baek, S.H. Yu, J.H. Nam, C.J. Kim, A numerical study on uniform cooling of large-scale PEMFCs with different coolant flow field designs, *Appl. Therm. Eng.* 31 (2011) 1427–1434, <https://doi.org/10.1016/j.applthermaleng.2011.01.009>.
- [45] S.M. Rahgoshay, A.A. Ranjbar, A. Ramiar, E. Alizadeh, Thermal investigation of a PEM fuel cell with cooling flow field, *Energy* 134 (2017) 61–73, <https://doi.org/10.1016/j.energy.2017.05.151>.
- [46] Q. Deng, Y. Liu, Y. Zhou, W. Chen, Z. Shen, B. Chen, Z. Tu, Evaluation of cooling flow field of proton exchange membrane fuel cell based on heat transfer performance enhancement, *Int. J. Energy Res.* 46 (2022) 12519–12529, <https://doi.org/10.1002/er.8023>.
- [47] K. Xiong, W. Wu, S. Wang, L. Zhang, Modeling, design, materials and fabrication of bipolar plates for proton exchange membrane fuel cell: a review, *Appl. Energy* 301 (2021) 117443, <https://doi.org/10.1016/j.apenergy.2021.117443>.
- [48] Q. Liu, F. Lan, C. Zeng, J. Chen, J. Wang, A review of proton exchange membrane fuel cell's bipolar plate design and fabrication process, *J. Power Sources* 538 (2022) 231543, <https://doi.org/10.1016/j.jpowsour.2022.231543>.
- [49] L. Rostami, M. Haghshenasfard, M. Sadeghi, M. Zhiani, A 3D CFD model of novel flow channel designs based on the serpentine and the parallel design for performance enhancement of PEMFC, *Energy* 258 (2022) 124726, <https://doi.org/10.1016/j.energy.2022.124726>.
- [50] Q. Zuo, Q. Li, W. Chen, R. Peng, X. Zhu, Y. Xie, Y. Tang, Z. Shen, X. Yang, Optimization of blocked flow field performance of proton exchange membrane fuel cell with auxiliary channels, *Int J Hydrogen Energy* 47 (94) (2022) 39943–39960, <https://doi.org/10.1016/j.ijhydene.2022.09.143>.
- [51] A. Hamrang, M. Abdollahzadeh, M.J. Kermani, S.M. Rahgoshay, Numerical simulation of the PEM fuel cell performance enhancement by various blockage arrangement of the cathode serpentine gas flow channel outlets/inlets, *Int. J. Heat Mass Transf.* 186 (2022) 122475, <https://doi.org/10.1016/j.ijheatmasstransfer.2021.122475>.
- [52] M. Ashrafi, H. Kanani, M. Shams, Numerical and experimental study of two-phase flow uniformity in channels of parallel PEM fuel cells with modified Z-type flow-fields, *Energy* 147 (2018) 317–328, <https://doi.org/10.1016/j.energy.2018.01.064>.
- [53] M. Ghasabehi, M. Ashrafi, M. Shams, Performance analysis of an innovative parallel flow field design of proton exchange membrane fuel cells using multiphysics simulation, *Fuel* 285 (2021) 119194, <https://doi.org/10.1016/j.fuel.2020.119194>.
- [54] Q. Liu, F. Lan, J. Chen, J. Wang, C. Zeng, Flow field structure design modification with helical baffle for proton exchange membrane fuel cell, *Energ. Convers. Manag.* 269 (2022) 116175, <https://doi.org/10.1016/j.enconman.2022.116175>.
- [55] L. He, M. Hou, Y. Gao, X. Sun, W. Song, L. Zheng, J. Ai, H. Zhang, Z. Shao, Experimental study of the S-shaped flow fields in proton exchange membrane fuel cells, *Energ. Convers. Manag.* 223 (2020) 113292, <https://doi.org/10.1016/j.enconman.2020.113292>.
- [56] C. Yin, Y. Song, M. Liu, Y. Gao, K. Li, Z. Qiao, H. Tang, Investigation of proton exchange membrane fuel cell stack with inversely phased wavy flow field design, *Appl. Energy* 305 (2022) 117893, <https://doi.org/10.1016/j.apenergy.2021.117893>.
- [57] X. Yan, C. Guan, Y. Zhang, K. Jiang, G. Wei, X. Cheng, S. Shen, J. Zhang, Flow field design with 3D geometry for proton exchange membrane fuel cells, *Appl. Therm. Eng.* 147 (2019) 1107–1114, <https://doi.org/10.1016/j.applthermaleng.2018.09.110>.
- [58] R. Liu, W. Zhou, S. Li, F. Li, W. Ling, Performance improvement of proton exchange membrane fuel cells with compressed nickel foam as flow field structure, *Int J Hydrogen Energy* 45 (2020) 17833–17843, <https://doi.org/10.1016/j.ijhydene.2020.04.238>.
- [59] M. Suo, K. Sun, R. Chen, Z. Che, Z. Zeng, Q. Li, X. Tao, T. Wang, Oxygen transport in proton exchange membrane fuel cells with metal foam flow fields, *J. Power Sources* 521 (2022) 230937, <https://doi.org/10.1016/j.jpowsour.2021.230937>.
- [60] D.G. Kang, D.K. Lee, J.M. Choi, D.K. Shin, M.S. Kim, Study on the metal foam flow field with porosity gradient in the polymer electrolyte membrane fuel cell, *Renew. Energy* 156 (2020) 931–941, <https://doi.org/10.1016/j.renene.2020.04.142>.
- [61] N. Li, W. Wang, R. Xu, J. Zhang, H. Xu, Design of a novel nautilus bionic flow field for proton exchange membrane fuel cell by analyzing performance, *Int. J. Heat Mass Transf.* 200 (2023) 123517, <https://doi.org/10.1016/j.ijheatmasstransfer.2022.123517>.
- [62] Y. Wang, C. Si, Y. Qin, X. Wang, Y. Fan, Y. Gao, Bio-inspired design of an auxiliary fishbone-shaped cathode flow field pattern for polymer electrolyte membrane fuel cells, *Energ. Convers. Manag.* 227 (2021) 113588, <https://doi.org/10.1016/j.enconman.2020.113588>.
- [63] L. Xia, Z. Yu, G. Xu, S. Ji, B. Sun, Design and optimization of a novel composite bionic flow field structure using three-dimensional multiphase computational fluid dynamic method for proton exchange membrane fuel cell, *Energ. Convers. Manag.* 247 (2021) 114707, <https://doi.org/10.1016/j.enconman.2021.114707>.
- [64] W. Dai, H. Wang, X. Yuan, J.J. Martin, D. Yang, J. Qiao, J. Ma, A review on water balance in the membrane electrode assembly of proton exchange membrane fuel cells, *Int J Hydrogen Energy* 34 (2009) 9461–9478, <https://doi.org/10.1016/j.ijhydene.2009.09.017>.
- [65] Q. Yan, H. Toghiani, J. Wu, Investigation of water transport through membrane in a PEM fuel cell by water balance experiments, *J. Power Sources* 158 (2006) 316–325, <https://doi.org/10.1016/j.jpowsour.2005.09.013>.
- [66] R. Bligny, T. Schmitt, J. Dillet, M. Hanauer, U. Sauter, G. Maranzana, In-situ estimation of water transfer parameters in a proton exchange membrane fuel cell, *J. Power Sources* 560 (2023) 232719, <https://doi.org/10.1016/j.jpowsour.2023.232719>.
- [67] R.C. Sellin, K. Mozet, A. Ménage, J. Dillet, S. Didierjean, G. Maranzana, Measuring electro-osmotic drag coefficients in PFSA membranes without any diffusion assumption, *Int J Hydrogen Energy* 44 (2019) 24905–24912, <https://doi.org/10.1016/j.ijhydene.2019.07.076>.
- [68] A.Z. Weber, J. Newman, Transport in polymer-electrolyte membranes: Iii. model validation in a simple fuel-cell model, *J. Electrochem. Soc.* 151 (2004) A326, <https://doi.org/10.1149/1.1639158>.
- [69] T.E. Springer, T.A. Zawodzinski, S. Gottesfeld, Polymer electrolyte fuel cell model, *J. Electrochem. Soc.* 138 (1991) 2334, <https://doi.org/10.1149/1.2085971>.
- [70] S. Gottesfeld, T.A. Zawodzinski, Polymer electrolyte fuel cells, *Adv. Electrochem. Sci. Eng.* 5 (1997) 195–301, <https://doi.org/10.1002/9783527616794>.
- [71] Y. Shao, L. Xu, J. Li, Z. Hu, C. Fang, J. Hu, D. Guo, M. Ouyang, Hysteresis of output voltage and liquid water transport in a gas diffusion layer of polymer electrolyte fuel cells, *Energ. Convers. Manag.* 185 (2019) 169–182, <https://doi.org/10.1016/j.enconman.2019.01.084>.
- [72] B. Xie, M. Ni, G. Zhang, X. Sheng, H. Tang, Y. Xu, G. Zhai, K. Jiao, Validation methodology for PEM fuel cell three-dimensional simulation, *Int. J. Heat Mass Transf.* 189 (2022) 122705, <https://doi.org/10.1016/j.ijheatmasstransfer.2022.122705>.
- [73] E.M. Rahimi, A.A. Ranjbar, A. Ramiar, E. Alizadeh, M. Aghaee, Improving PEM fuel cell performance and effective water removal by using a novel gas flow field, *Int J Hydrogen Energy* 41 (2016) 3023–3037, <https://doi.org/10.1016/j.ijhydene.2015.11.001>.
- [74] G. Zhang, Three-dimensional multi-phase simulation of PEMFC at high current density utilizing Eulerian-Eulerian model and two-fluid model, *Energ. Convers. Manag.* 176 (2018) 409–421, <https://doi.org/10.1016/j.enconman.2018.09.031>.
- [75] Y. Wang, S. Wang, G. Wang, L. Yue, Numerical study of a new cathode flow-field design with a sub-channel for a parallel flow-field polymer electrolyte membrane fuel cell, *Int J Hydrogen Energy* 43 (2018) 2359–2368, <https://doi.org/10.1016/j.ijhydene.2017.11.172>.
- [76] D. Jiao, K. Jiao, Q. Du, Numerical investigations of vapor condensation and water transport in gas diffusion layers of PEMFC, *Int. J. Heat Mass Transf.* 177 (2021) 121543, <https://doi.org/10.1016/j.ijheatmasstransfer.2021.121543>.
- [77] B. Dokkar, N.E. Settou, O. Imine, N. Saifi, B. Negrou, Z. Nemouchi, Simulation of species transport and water management in PEM fuel cells, *Int J Hydrogen Energy* 36 (2011) 4220–4227, <https://doi.org/10.1016/j.ijhydene.2010.09.060>.
- [78] Y. Yang, H. Jia, Z. Liu, N. Bai, X. Zhang, T. Cao, J. Zhang, P. Zhao, X. He, Overall and local effects of operating parameters on water management and performance of open-cathode PEM fuel cells, *Appl. Energy* 315 (2022) 118978, <https://doi.org/10.1016/j.apenergy.2022.118978>.
- [79] K. Zhu, Q. Ding, J. Xu, Y. Yang, Y. Chen, J. Zhang, Y. Zhang, T. Huang, W. Yan, Z. Wan, X. Wang, Optimization of gas diffusion layer thickness for proton exchange membrane fuel cells under steady-state and load-varying conditions, *Energ. Convers. Manag.* 267 (2022) 115915, <https://doi.org/10.1016/j.enconman.2022.115915>.
- [80] M. Göbel, M. Godehardt, K. Schladitz, Multi-scale structural analysis of gas diffusion layers, *J. Power Sources* 355 (2017) 8–17, <https://doi.org/10.1016/j.jpowsour.2017.03.086>.
- [81] E. Carcadea, M. Varlam, M. Ismail, D.B. Ingham, A. Mariniou, M. Raceanu, C. Jianu, L. Patularu, E.D. Ion, PEM fuel cell performance improvement through numerical optimization of the parameters of the porous layers, *Int J Hydrogen Energy* 45 (2020) 7968–7980, <https://doi.org/10.1016/j.ijhydene.2019.08.219>.

- [82] X. Ma, X. Zhang, J. Yang, W. Zhuge, S. Shuai, Impact of gas diffusion layer spatial variation properties on water management and performance of PEM fuel cells, *Energ. Convers. Manag.* 227 (2021) 113579, <https://doi.org/10.1016/j.enconman.2020.113579>.
- [83] R. Zhu, Z. Zhan, H. Zhang, Q. Du, X. Chen, X. Xiang, X. Wen, M. Pan, Effects of cathode GDL gradient porosity distribution along the flow channel direction on gas-liquid transport and performance of PEMFC, *Polymers* 15 (2023) 1629, <https://doi.org/10.3390/polym15071629>.
- [84] F.S. Nanadegani, E.N. Lay, B. Sunden, Effects of an MPL on water and thermal management in a PEMFC, *Int. J. Energy Res.* 43 (2019) 274–296, <https://doi.org/10.1002/er.4262>.
- [85] X. Wang, T.V. Nguyen, Modeling the effects of the cathode micro-porous layer on the performance of a PEM fuel cell, *ECS Trans.* 16 (2008) 3, <https://doi.org/10.1149/1.2981838>.
- [86] R. Banerjee, S.G. Kandlikar, Two-phase flow and thermal transients in proton exchange membrane fuel cells – a critical review, *Int J Hydrogen Energy* 40 (2015) 3990–4010, <https://doi.org/10.1016/j.ijhydene.2015.01.126>.
- [87] O.S. Burheim, J.G. Pharoah, A review of the curious case of heat transport in polymer electrolyte fuel cells and the need for more characterisation, *Curr. Opin. Electroche* 5 (2017) 36–42, <https://doi.org/10.1016/j.coelec.2017.09.020>.
- [88] A.S. Alavijeh, R.M.H. Khorasany, Z. Nunn, A. Habisch, M. Lauritzen, E. Rogers, G. Wang, E. Kjeang, Microstructural and mechanical characterization of catalyst coated membranes subjected to in situ hydrothermal fatigue, *J. Electrochem. Soc.* 162 (2015) F1461–F1469, <https://doi.org/10.1149/2.0471514jes>.
- [89] X. Yan, Y. Peng, Y. Shen, S. Shen, G. Wei, J. Yin, J. Zhang, The use of phase-change cooling strategy in proton exchange membrane fuel cells: a numerical study, *Sci. China Technol. Sc* 64 (2021) 2762–2770, <https://doi.org/10.1007/s11431-021-1889-4>.
- [90] E. Afshari, R.M. Ziaei, M.M. Dehkordi, Numerical investigation on a novel zigzag-shaped flow channel design for cooling plates of PEM fuel cells, *J. Energy Inst.* 90 (2017) 752–763, <https://doi.org/10.1016/j.joei.2016.07.002>.
- [91] M.L. Perry, J.P. Meyers, R.M. Darling, C. Evans, R. Balliet, Evaporatively-cooled PEM fuel-cell stack and system, *ECS Trans.* 3 (2006) 1207–1214, <https://doi.org/10.1149/1.2356240>.
- [92] J. Clement, X. Wang, Experimental investigation of pulsating heat pipe performance with regard to fuel cell cooling application, *Appl. Therm. Eng.* 50 (2013) 268–274, <https://doi.org/10.1016/j.applthermaleng.2012.06.017>.
- [93] S.A. Atyabi, E. Afshari, C. Udemu, Comparison of active and passive cooling of proton exchange membrane fuel cell using a multiphase model, *Energ. Convers. Manag.* 268 (2022) 115970, <https://doi.org/10.1016/j.enconman.2022.115970>.
- [94] M.R. Islam, B. Shabani, G. Rosengarten, Nanofluids to improve the performance of PEM fuel cell cooling systems: a theoretical approach, *Appl. Energy* 178 (2016) 660–671, <https://doi.org/10.1016/j.apenergy.2016.06.090>.
- [95] W.F. Areat, A.R.N. Zeiny, M.A.R.S. Al-Baghdati, Influence of Al₂O₃-water nanofluid coolant on thermal performance of hydrogen PEM fuel cell stacks, *IOP Conf. Ser. Mater. Sci. Eng.* 1094 (2021) 012064, <https://doi.org/10.1088/1757-899X/1094/1/012064>.
- [96] R. Islam, B. Shabani, J. Andrews, G. Rosengarten, Experimental investigation of using ZnO nanofluids as coolants in a PEM fuel cell, *Int J Hydrogen Energy* 42 (2017) 19272–19286, <https://doi.org/10.1016/j.ijhydene.2017.06.087>.
- [97] I. Zakaria, W.A.N.W. Mohamed, W.H. Azmi, A.M.I. Mamat, R. Mamat, W.R. W. Daud, Thermo-electrical performance of PEM fuel cell using Al₂O₃ nanofluids, *Int. J. Heat Mass Transf.* 119 (2018) 460–471, <https://doi.org/10.1016/j.ijheatmasstransfer.2017.11.137>.
- [98] L. Xing, W. Xiang, R. Zhu, Z. Tu, Modeling and thermal management of proton exchange membrane fuel cell for fuel cell/battery hybrid automotive vehicle, *Int J Hydrogen Energy* 47 (2022) 1888–1900, <https://doi.org/10.1016/j.ijhydene.2021.10.146>.
- [99] C. Damour, M. Benne, P.B. Grondin, J.P. Chabriet, Neural model-based self-tuning PID strategy applied to PEMFC, *Engineering* 6 (2014) 159–168, <https://doi.org/10.4236/eng.2014.64019>.
- [100] X. Chen, Y. Fang, Q. Liu, L. He, Y. Zhao, T. Huang, Z. Wan, X. Wang, Temperature and voltage dynamic control of PEMFC stack using MPC method, *Energy Rep.* 8 (2022) 798–808, <https://doi.org/10.1016/j.egyr.2021.11.271>.
- [101] Y. Wang, F. Qin, K. Ou, Y.B. Kim, Temperature control for a polymer electrolyte membrane fuel cell by using fuzzy rule, *IEEE T Energy Convers.* 31 (2016) 667–675, <https://doi.org/10.1109/TEC.2015.2511155>.
- [102] W. Zou, Y. Kim, Temperature control for a 5 kW water-cooled PEM fuel cell system for a household application, *IEEE Access* 7 (2019) 144826–144835, <https://doi.org/10.1109/ACCESS.2019.2945986>.
- [103] X. Chen, J. Xu, Y. Fang, W. Li, Y. Ding, Z. Wan, X. Wang, Z. Tu, Temperature and humidity management of PEM fuel cell power system using multi-input and multi-output fuzzy method, *Appl. Therm. Eng.* 203 (2022) 117865, <https://doi.org/10.1016/j.applthermaleng.2021.117865>.
- [104] S. Xiong, Z. Wu, W. Li, D. Li, T. Zhang, Y. Lan, X. Zhang, S. Ye, S. Peng, Z. Han, J. Zhu, Q. Song, Z. Jiao, X. Wu, H. Huang, Improvement of temperature and humidity control of proton exchange membrane fuel cells, *Sustainability* 13 (2021) 10578, <https://doi.org/10.3390/su131910578>.
- [105] C. Wu, J. Chen, C. Xu, Z. Liu, Real-time adaptive control of a fuel cell/battery hybrid power system with guaranteed stability, *IEEE Trans. Contr. Syst. Technol.* 25 (2017) 1394–1405, <https://doi.org/10.1109/TCST.2016.2611558>.
- [106] J. Han, S. Yu, S. Yi, Advanced thermal management of automotive fuel cells using a model reference adaptive control algorithm, *Int J Hydrogen Energy* 42 (2017) 4328–4341, <https://doi.org/10.1016/j.ijhydene.2016.10.134>.
- [107] L. Huang, J. Chen, Z. Liu, M. Becherif, Adaptive thermal control for PEMFC systems with guaranteed performance, *Int J Hydrogen Energy* 43 (2018) 11550–11558, <https://doi.org/10.1016/j.ijhydene.2017.12.121>.
- [108] N. Chatrattanakawet, T. Hakhen, S. Kheawhom, A. Arpornwichanop, Control structure design and robust model predictive control for controlling a proton exchange membrane fuel cell, *J. Clean. Prod.* 148 (2017) 934–947, <https://doi.org/10.1016/j.jclepro.2017.02.033>.
- [109] H.Q. Nguyen, B. Shabani, Proton exchange membrane fuel cells heat recovery opportunities for combined heating/cooling and power applications, *Energ. Convers. Manag.* 204 (2020) 112328, <https://doi.org/10.1016/j.enconman.2019.112328>.
- [110] Y. Han, C. Lai, J. Li, Z. Zhang, H. Zhang, S. Hou, F. Wang, J. Zhao, C. Zhang, H. Miao, J. Yuan, Elastocaloric cooler for waste heat recovery from proton exchange membrane fuel cells, *Energy* 238 (2022) 121789, <https://doi.org/10.1016/j.energy.2021.121789>.
- [111] W. Sun, F. Yi, D. Hu, J. Zhou, Research on matching design method of waste heat reuse system of fuel cell vehicle considering system energy consumption and waste heat exchange rate, *Int. J. Energy Res.* 45 (2021) 5470–5485, <https://doi.org/10.1002/er.6175>.
- [112] W.A.N. Mohamed, M.H. Kamil, Hydrogen preheating through waste heat recovery of an open-cathode PEM fuel cell leading to power output improvement, *Energ. Convers. Manag.* 124 (2016) 543–555, <https://doi.org/10.1016/j.enconman.2016.07.046>.
- [113] L. Li, Z. Liu, C. Deng, N. Xie, J. Ren, Y. Sun, Z. Xiao, K. Lei, S. Yang, Thermodynamic and exergoeconomic analyses of a vehicular fuel cell power system with waste heat recovery for cabin heating and reactants preheating, *Energy* 247 (2022) 123465, <https://doi.org/10.1016/j.energy.2022.123465>.
- [114] Y.P. Fernández, V. Romero, O. Armas, G. Cerretti, Thermal management of thermoelectric generators for waste energy recovery, *Appl. Therm. Eng.* 196 (2021) 117291, <https://doi.org/10.1016/j.applthermaleng.2021.117291>.
- [115] Y. Cai, W. Wang, L. Wang, D. Liu, F. Zhao, A proton exchange membrane fuel cell-compound thermoelectric system: bidirectional modeling and energy conversion potentials, *Energ. Convers. Manag.* 207 (2020) 112517, <https://doi.org/10.1016/j.enconman.2020.112517>.
- [116] H. Pourrahmani, H. Shakeri, Van herle J., Thermoelectric generator as the waste heat recovery unit of proton exchange membrane fuel cell: a numerical study, *Energies* 15 (2022) 3018, <https://doi.org/10.3390/en15093018>.
- [117] M. Hasani, N. Rahbar, Application of thermoelectric cooler as a power generator in waste heat recovery from a PEM fuel cell – an experimental study, *Int J Hydrogen Energy* 40 (2015) 15040–15051, <https://doi.org/10.1016/j.ijhydene.2015.09.023>.
- [118] M. Saufi Sulaiman, B. Singh, W.A.N.W. Mohamed, Experimental and theoretical study of thermoelectric generator waste heat recovery model for an ultra-low temperature PEM fuel cell powered vehicle, *Energy* 179 (2019) 628–646, <https://doi.org/10.1016/j.energy.2019.05.022>.
- [119] M. Alam, K. Kumar, V. Dutta, Dynamic modeling and experimental analysis of waste heat recovery from the proton exchange membrane fuel cell using thermoelectric generator, *Therm. Sci. Eng. Prog.* 19 (2020) 100627, <https://doi.org/10.1016/j.tsep.2020.100627>.
- [120] C. Liu, Y. Jiang, W. Han, Q. Kang, A high-temperature hybrid absorption-compression heat pump for waste heat recovery, *Energ. Convers. Manag.* 172 (2018) 391–401, <https://doi.org/10.1016/j.enconman.2018.07.027>.
- [121] T. He, R. Shi, J. Peng, W. Zhuge, Y. Zhang, Waste heat recovery of a PEMFC system by using organic rankine cycle, *Energies* 9 (2016) 267, <https://doi.org/10.3390/en9040267>.
- [122] H. Lee, D. Lee, Y. Kim, Heating performance of a coolant-source heat pump using waste heat from stack and electric devices in fuel cell electric vehicles under cold conditions, *Energ. Convers. Manag.* 252 (2022) 115092, <https://doi.org/10.1016/j.enconman.2021.115092>.
- [123] S.M. Alijanpour, S.S.A. Mousavi, M.A. Delavar, Waste heat recovery from a 1180 kW proton exchange membrane fuel cell (PEMFC) system by recuperative organic rankine cycle (ORC), *Energy* 157 (2018) 353–366, <https://doi.org/10.1016/j.energy.2018.05.132>.
- [124] Z. Zhao, T. Wang, B. Zhang, Y. Wang, C. Bao, Z. Ji, Analysis of an integrated thermal management system with a heat-pump in a fuel cell vehicle, *AIP Adv.* 11 (2021) 065307, <https://doi.org/10.1063/5.0056364>.
- [125] X. Han, H. Zou, J. Wu, C. Tian, M. Tang, G. Huang, Investigation on the heating performance of the heat pump with waste heat recovery for the electric bus, *Renew. Energy* 152 (2020) 835–848, <https://doi.org/10.1016/j.renene.2020.01.075>.
- [126] G. Montaner Ríos, J. Schirmer, C. Gentner, J. Kallio, Efficient thermal management strategies for cold starts of a proton exchange membrane fuel cell system, *Appl. Energy* 279 (2020) 115813, <https://doi.org/10.1016/j.apenergy.2020.115813>.
- [127] X. Yang, J. Sun, S. Sun, Z. Shao, An efficient cold start strategy for proton exchange membrane fuel cell stacks, *J. Power Sources* 542 (2022) 231492, <https://doi.org/10.1016/j.jpowsour.2022.231492>.
- [128] M. Pan, D. Li, C. Pan, L. Liang, Maximum power tracking-based adaptive cold start strategy for proton exchange membrane fuel cell, *Energy Convers. Manag.* 273 (2022) 116387, <https://doi.org/10.1016/j.enconman.2022.116387>.
- [129] H. Chang, F. Cai, Z. Yang, C. Duan, Z. Tu, Experimental study on the endplate effect on the cold-start performance of an open-cathode air-cooled proton exchange membrane fuel cell stack, *Int J Hydrogen Energy* 48 (2023) 15215–15228, <https://doi.org/10.1016/j.ijhydene.2023.01.003>.
- [130] Z. Qin, K. Wu, S. Wu, Q. Du, Y. Yin, B. Wang, et al., Investigation of assisted heating cold start strategies from –40 °C for proton exchange membrane fuel cell

- stack, *Int. J. Green Energy* 20 (2023) 1559–1572, <https://doi.org/10.1080/15435075.2022.2163590>.
- [131] Q. Cao, H. Min, W. Sun, H. Zhao, Y. Yu, Z. Zhang, et al., A method of combining active and passive strategies by genetic algorithm in multi-stage cold start of proton exchange membrane fuel cell, *Energy* 288 (2024) 129794, <https://doi.org/10.1016/j.energy.2023.129794>.
- [132] Z. Yang, Q. Du, Z. Jia, C. Yang, K. Jiao, Effects of operating conditions on water and heat management by a transient multi-dimensional PEMFC system model, *Energy* 183 (2019) 462–476, <https://doi.org/10.1016/j.energy.2019.06.148>.
- [133] X. Li, K. Han, Y. Song, Dynamic behaviors of PEM fuel cells under load changes, *Int J Hydrogen Energy* 45 (2020) 20312–20320, <https://doi.org/10.1016/j.ijhydene.2019.12.034>.
- [134] T.B.H. Tran, P. Huguet, A. Morin, M. Robitzer, S. Deabate, Operando μ -Raman study of the membrane water content in the polymer electrolyte membrane fuel cell: effects of gas flow-field geometry and temperature, *Electrochim. Acta* 372 (2021) 137904, <https://doi.org/10.1016/j.electacta.2021.137904>.
- [135] W. Ying, T. Yang, W.Y. Lee, J. Ke, C.S. Kim, Three-dimensional analysis for effect of channel configuration on the performance of a small air-breathing proton exchange membrane fuel cell (PEMFC), *J. Power Sources* 145 (2005) 572–581, <https://doi.org/10.1016/j.jpowsour.2005.02.066>.
- [136] M. Sarker, M.A. Rahman, F. Mojica, S. Mehrazi, K.W.J.M. Kort, P.Y.A. Chuang, Experimental and computational study of the microporous layer and hydrophobic treatment in the gas diffusion layer of a proton exchange membrane fuel cell, *J. Power Sources* 509 (2021) 230350, <https://doi.org/10.1016/j.jpowsour.2021.230350>.
- [137] L. Fan, G. Zhang, K. Jiao, Characteristics of PEMFC operating at high current density with low external humidification, *Energ. Convers. Manag.* 150 (2017) 763–774, <https://doi.org/10.1016/j.enconman.2017.08.034>.
- [138] G. Zhang, L. Fan, J. Sun, K. Jiao, A 3D model of PEMFC considering detailed multiphase flow and anisotropic transport properties, *Int. J. Heat Mass Transf.* 115 (2017) 714–724, <https://doi.org/10.1016/j.ijheatmasstransfer.2017.07.102>.
- [139] J. Shen, Z. Tu, S.H. Chan, Performance enhancement in a proton exchange membrane fuel cell with a novel 3D flow field, *Appl. Therm. Eng.* 164 (2020) 114464, <https://doi.org/10.1016/j.applthermaleng.2019.114464>.
- [140] L. He, M. Hou, Y. Gao, D. Fang, P. Wang, B. Lv, Z. Shao, A novel three-dimensional flow field design and experimental research for proton exchange membrane fuel cells, *Energ. Convers. Manag.* 205 (2020) 112335, <https://doi.org/10.1016/j.enconman.2019.112335>.
- [141] H. Wang, G. Yang, S. Li, Q. Shen, F. Su, Z. Jiang, J. Liao, X. Pan, Pore-scale modeling of mass transport in partially saturated cathode gas diffusion layers of proton exchange membrane fuel cell, *Energy Fuel* 36 (2022) 8422–8431, <https://doi.org/10.1021/acs.energyfuels.2c01741>.
- [142] L. Zhang, Y. Liu, P. Pei, X. Liu, L. Wang, Y. Wan, Variation characteristic analysis of water content at the flow channel of proton exchange membrane fuel cell, *Energies* 15 (2022) 3280, <https://doi.org/10.3390/en15093280>.
- [143] X. Zhang, X. Ma, J. Yang, X. Zhu, S. Tai, S. Shuai, Effect of liquid water in flow channel on proton exchange membrane fuel cell: focusing on flow pattern, *Energ. Convers. Manag.* 258 (2022) 115528, <https://doi.org/10.1016/j.enconman.2022.115528>.
- [144] A. Benmouna, M. Becherif, D. Depernet, et al., Fault diagnosis methods for proton exchange membrane fuel cell system, *Int J Hydrogen Energy* 42 (2) (2017) 1534–1543, <https://doi.org/10.1016/j.ijhydene.2016.07.181>.
- [145] Y. Luo, K. Jiao, Cold start of proton exchange membrane fuel cell, *Prog. Energy Combust. Sci.* 64 (2018) 29–61, <https://doi.org/10.1016/j.pecs.2017.10.003>.
- [146] X. Yang, J. Sun, X. Meng, S. Sun, Z. Shao, Cold start degradation of proton exchange membrane fuel cell: dynamic and mechanism, *Chem. Eng. J.* 455 (2023) 140823, <https://doi.org/10.1016/j.cej.2022.140823>.
- [147] C. Li, D. Si, Y. Liu, J. Zhang, Y. Liu, Water management characteristics of electrospun micro-porous layer in PEMFC under normal temperature and cold start conditions, *Int J Hydrogen Energy* 46 (2021) 11150–11159, <https://doi.org/10.1016/j.ijhydene.2020.05.271>.
- [148] Z. Chen, Y. Utaka, J. Xu, Y. Wang, Freezing characteristics of supercooled water in gas diffusion layer of proton exchange membrane fuel cells, *Int J Hydrogen Energy* 48 (2023) 25527–25537, <https://doi.org/10.1016/j.ijhydene.2023.03.294>.
- [149] G. Wang, Y. Utaka, S. Wang, Improvement of cold start performance of polymer electrolyte fuel cell using microporous and gas diffusion layers with patterned wettability, *Int. J. Energy Res.* 45 (2021) 13760–13770, <https://doi.org/10.1002/er.6704>.
- [150] R. Haider, Y. Wen, Z.-F. Ma, D.P. Wilkinson, L. Zhang, X. Yuan, et al., High temperature proton exchange membrane fuel cells: progress in advanced materials and key technologies, *Chem. Soc. Rev.* 50 (2021) 1138–1187, <https://doi.org/10.1039/D0CS00296H>.
- [151] F. Liu, X. Li, P. Zhao, X. Sun, J. Zhao, J. Shen, et al., Sensitivity analysis of operating parameters of proton exchange membrane fuel cells, *Ionics* 29 (2023) 5431–5440, <https://doi.org/10.1007/s11581-023-05180-y>.
- [152] Y.S. Kim, D.K. Kim, K.Y. Ahn, M.S. Kim, Real-time analysis of dry start-up characteristics of polymer electrolyte membrane fuel cell with water storage process under pressurized condition, *Energy* 199 (2020) 117292, <https://doi.org/10.1016/j.energy.2020.117292>.
- [153] S. Zhou, L. Rasha, L. Xu, W. Du, Shearing PaulR, M.-O. Coppens, et al., Nonuniform compensation of current density distribution in polymer electrolyte fuel cells by local heating, *Energ. Convers. Manag.* 297 (2023) 117717, <https://doi.org/10.1016/j.enconman.2023.117717>.