

Integration of Genetic Algorithm and Monte Carlo Simulation for System Design and Cost Allocation Optimization in Complex Network

Baladeh, Aliakbar Eslami; Khakzad, Nima

DOI

[10.1109/ICSRS.2018.8688846](https://doi.org/10.1109/ICSRS.2018.8688846)

Publication date

2019

Document Version

Accepted author manuscript

Published in

Proceedings - 2018 3rd International Conference on System Reliability and Safety, ICSRS 2018

Citation (APA)

Baladeh, A. E., & Khakzad, N. (2019). Integration of Genetic Algorithm and Monte Carlo Simulation for System Design and Cost Allocation Optimization in Complex Network. In *Proceedings - 2018 3rd International Conference on System Reliability and Safety, ICSRS 2018* (pp. 182-186). Article 8688846 Institute of Electrical and Electronics Engineers (IEEE). <https://doi.org/10.1109/ICSRS.2018.8688846>

Important note

To cite this publication, please use the final published version (if applicable).
Please check the document version above.

Copyright

Other than for strictly personal use, it is not permitted to download, forward or distribute the text or part of it, without the consent of the author(s) and/or copyright holder(s), unless the work is under an open content license such as Creative Commons.

Takedown policy

Please contact us and provide details if you believe this document breaches copyrights.
We will remove access to the work immediately and investigate your claim.

Integration of Genetic Algorithm and Monte Carlo Simulation for System Design and Cost Allocation Optimization in Complex Network

Aliakbar Eslami Baladeh
MAPNA Group
Tehran, Iran
e-mail: eslami.aliakbar@mapnaec.com

Nima Khakzad
Faculty of Technology, Policy, and Management, Delft
University of Technology, The Netherlands
e-mail: n.khakzadrostami@tudelft.nl

Abstract—Complex networks play a vital role in reliability analysis of real-world applications, demanding for precise and accurate analysis methods for optimal allocations of cost and reliability. Since the configuration of a system may change with every feasible solution of cost allocation optimization equation, finding the best arrangement of the system can become very challenging. This paper presents a novel methodology by combining Genetic Algorithm (GA) and Monte Carlo (MC) simulation approaches to simultaneously optimize cost allocation and system configuration in complex network. GA is used to generate configuration-cost pairs while MC is used to evaluate the reliability of the system for each pair. The application of the developed methodology is demonstrated for power grids as an example of critical complex networks. The results show that the proposed methodology can be readily used in practice.

Keywords—reliability; cost allocation; complex networks; optimization; Monte Carlo simulation; genetic algorithm

I. INTRODUCTION

Complex networks are broadly used to model many industrial systems such as power grids, oil and gas facilities, transportation networks, and communication systems [1]. To solve complex networks, many researchers have proposed various exact and approximate methods [2, 3]. Due to the complexity of such networks, simulation methods are extensively used to evaluate them. Monte Carlo (MC) simulation is an efficient modeling technique for the evaluation of complex systems [4]. Much research on precision and time improvement of reliability evaluation techniques of complex networks has been done [5].

Reliability and cost allocation is an important task in the system development, which decides how the budget should be allocated to satisfy system expectations, such as maximum reliability. In this regard, configuration of system and quality and number of components should be determined. According to its importance, in the last few years there has been a growing interest in reliability allocation optimization [6, 7].

The complex network reliability allocation is an NP-hard problem, so meta-heuristics algorithms have been widely used to find optimal solutions of this problem [8]. Genetic Algorithm (GA) is a powerful algorithm in reliability optimization, due to its capability of finding near optimal solutions in an acceptable time [9-12].

Simulation based techniques have been widely used to analyze reliability of complex networks [4]. MC simulation is a popular approach to evaluate systems with complex configurations [13, 14]. Much research has been carried out to enhance MC simulation for improvement the precise and time of reliability evaluation of complex systems [15]. MC simulation has been employed to estimate reliability of complex system in different industrial applications, such as wireless networks [16], distribution systems [17], marine [18] and oil and gas [19].

In recent years, integration of meta-heuristics algorithms with MC simulation has attracted much attention from research teams in the reliability engineering field. The results obtained by Marseguerra et al. [20] suggest that coupled GA and MC approach is useful in condition-based maintenance optimization. Another solution was developed by Yeh et al. [21] by integrating Particle Swarm Optimization (PSO) and MC simulation to solve complex networks. Marseguerra et al. [22] have also found that combined GA and MC simulation is practical in the redundancy optimization problems.

Reliability is an essential parameter in power industry [23]. Previous research has demonstrated the MC simulation application to reliability assessment of power system [24]. Power grid is a critical infrastructure in power systems in order to convey power from power plants to customers. power grid can be modeled as a complex network [25]. Reliability allocation in such systems is important because of their implementation and unavailability costs [26]. Niyato et al. [27] presented a novel reliability analysis to design redundancy of the wireless communications systems in smart grids. Shi et al. developed a redundancy optimization model for smart grid [28].

In spite of the relation between cost allocation and system configuration problems, previous studies in complex network have addressed these issues individually. The main objective of the current work is presenting a new algorithm to find an optimal configuration and cost allocation of complex networks in the same time.

II. PROBLEM STATEMENT

A reliability network can be represented by an adjacency matrix. An element a_{ij} of the adjacency matrix is equal to 1 if the i -th (row) and j -th (column) nodes are connected, and

zero otherwise. The adjacent matrix is symmetric about the main diagonal ($a_{ij} = a_{ji}$) [29]. In this study, all nodes of the system are perfectly reliable and reliability of component is shown on the connections (r_{ij}); each connection has two mutually exclusive states, working and failed. The connection states are s-independent. The graph is connected, and free of self-loops.

In this paper, we have assumed that the system configuration is not fixed and could change throughout connections and nodes. Therefore the first step is determine all possible connections among and the nodes of the system.

Reliability of each connection is related to an allocated cost, which can be calculated by cost function in Equation (1) that can be rewritten as Equation (2) [30].

$$cc_{ij} = cmin_{ij} e^{(1-f_{ij}) \frac{r_{ij} - rmin_{ij}}{rmax_{ij} - r_{ij}}} \quad (1)$$

$$r_{ij} = \frac{\left(\frac{\ln(cc_{ij}/cmin_{ij})}{1 - f_{ij}} \right) rmax_{ij} + rmin_{ij}}{\left(\frac{\ln(cc_{ij}/cmin_{ij})}{1 - f_{ij}} \right) + 1} \quad (2)$$

where:

- $i, j =$ indices of possible connected nodes in the system
- $cc_{ij} =$ allocated cost to the connection between nodes i and j
- $cmin_{ij} =$ cost of the connection between nodes i and j
- $rmin_{ij} =$ reliability of the connection between nodes i and j according to the allocated cost cc_{ij}
- $rmax_{ij} =$ minimum reliability of the connection between nodes i and j corresponding to the allocated cost
- $rmax_{ij} =$ maximum achievable reliability of the connection between nodes i and j
- $f_{ij} =$ cost function or feasibility of increasing the connection between nodes i and j reliability which relies on the criticality, the state of the art, the complexity, the working condition and availability of the component.

The main question is how much cost should be assigned to each connection to reach the maximum reliability of the system (R_{system}). The mathematical formulation of the problem is shown in Equations (3)-(9). Equation (4) assures that the total allocated cost is less than the available budget (B). Equations (5) and (6) demonstrate that the lower bound of the allocated cost of each connection is limited to the minimum cost ($cmin_{ij}$). Equation (7) identifies that according to the selected connections, every related node with selected connections should be activated, for example, if connection between nodes $i=2, j=3$ is selected, node 2 and 3 must be activated.

$$\max R_{system} \quad (3)$$

Subject to:

$$\sum_{i=1}^I \sum_{j=1}^I cc_{ij} + \sum_{j=1}^I x_j nc_j \leq B \quad (4)$$

$$cc_{ij} \geq cmin_{ij} y_{ij} \quad , \quad i, j=1, 2, \dots, I \quad (5)$$

$$cc_{ij} \leq y_{ij} K_1 \quad , \quad i, j=1, 2, \dots, I \quad (6)$$

$$K_2 x_i \geq cc_{ij} \quad , \quad i, j=1, 2, \dots, I \quad (7)$$

$$x_i \in \{0, 1\}, cc_{ij} \geq 0 \quad , \quad i, j=1, 2, \dots, I \quad (8)$$

where:

$x_i =$ binary variable to show whether node i is selected or not

$y_{ij} =$ auxiliary binary variable

$nc_i =$ cost of node i

$R_{system} =$ total reliability of the system

$B =$ total available budget

$K_{1,2} =$ a fixed big number

GA as a powerful algorithm is selected to find optimal solution of the problem. Allocated cost to each connection (decision variable) is represented as a chromosome of GA. The length of every chromosome is equal to the maximum number of possible connections the value of which should be zero (if the connection is not selected) or greater than minimum cost ($cmin_{ij}$) otherwise (Fig. 1).

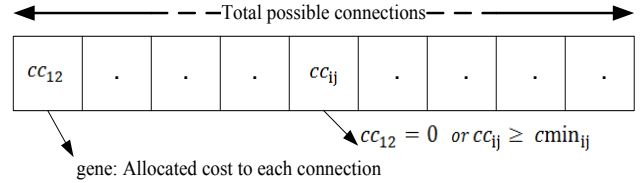

Figure 1. Suggested GA's chromosome representation.

The total reliability of the system (R_{system}) is the fitness function of each chromosome. The configuration of the system may change according to feasible answers of the solution space; to overcome this issue, MC simulation can be used as shown in Fig. 2. For each chromosome the algorithm runs for N_{max} times, and in each iteration for all selected connection creates a random number: if this number is greater than the reliability of connection, the related cell in the adjacency matrix will be set to 0, or else to 1. Then, if there is any path from the power plant to consumers, the counter of success will increase by unity. Finally, the reliability of the system (R_{system}) can be approximated as the ratio of the total number of successes to the total number of iterations (N_{max}).

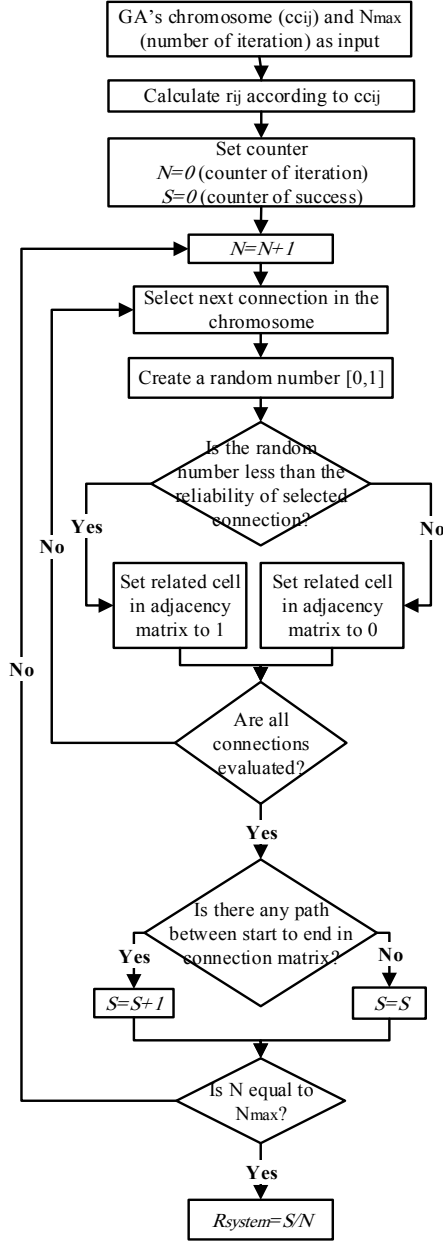

Figure 2. Proposed algorithm to evaluate GA's chromosome.

III. APPLICATION ON POWER GRID SYSTEM

Power grids, used for electricity transmission and distribution, are amongst critical infrastructures. For today's society. Reliability is an important parameter in designing the type and route of power grid to transfer electricity from power plants to consumers. However, extreme cost of transmission lines and substations also demands for taking into account cost as another important parameter in the design of power grids. Therefore, the designer should determine which transmission line and substation could satisfy cost and reliability requirements. In this section, the proposed algorithm is applied to a small size power grid

system with transmission lines and substations as the connections and nodes of the network. The adjacency matrix of the power grid system is illustrated in Fig. 3. Also Fig. 4 depicts transition lines (arc) to the potential substations (nodes) in the power grid system.

node	start	1	2	3	4	5	6	7	8	9	end
start	-	A	B	C	0	0	0	0	0	0	0
1		-	0	0	D	0	G	0	0	0	0
2			-	0	0	F	H	0	0	0	0
3				-	E	0	I	J	0	K	0
4					-	0	0	0	L	0	0
5						-	0	0	M	N	0
6							-	0	O	P	0
7								-	0	Q	0
8									-	R	S
9										-	T
end											-

Figure 3. Adjacency matrix of the power grid system

Implementation cost of each substation is shown in Table I.

TABLE I. COST OF SUBSTATIONS

Substation (node)	1	2	3	4	5	6	7	8	9
Node Cost (nc _i)	7	8	7	6	5	6	5	4	4

The required information about transmission lines is provided in Table II. The available budget (B) for the power grid is assumed as 110 units.

To solve cost allocation of the power grid system, according to our experience, the GA parameters such as population size, number of generations, mutation rate, and crossover are set to 100, 300, 0.7, and 0.1 respectively. The total number of iteration for each solution is considered as 500 ($N_{max}=500$). The optimal design and the allocated cost of the power grid is shown in Fig. 5, with the respective total reliability of 98.85% and the cost of 109.99 units.

IV. CONCLUSION

In the present study we demonstrated that integration of genetic algorithm and Monte Carlo simulation can effectively be used for optimal design of large-sized complex networks with regards to reliability and cost. Although we showed the methodology's application to a power grid system, it can be applied to other real-world complex networks such as transportation networks. The developed methodology is also able to be expanded by taking into account other constraints and goals, such as minimum level of system reliability and availability of system, discussed in pervious publications. The present research was concerned with the cost allocation; however, the developed methodology could readily be applied to other problems such as redundancy allocation and maintenance optimization. To verify the efficacy of the developed methodology, a comparison can be made with other complex network modeling approaches such as Petri nets and Bayesian networks.

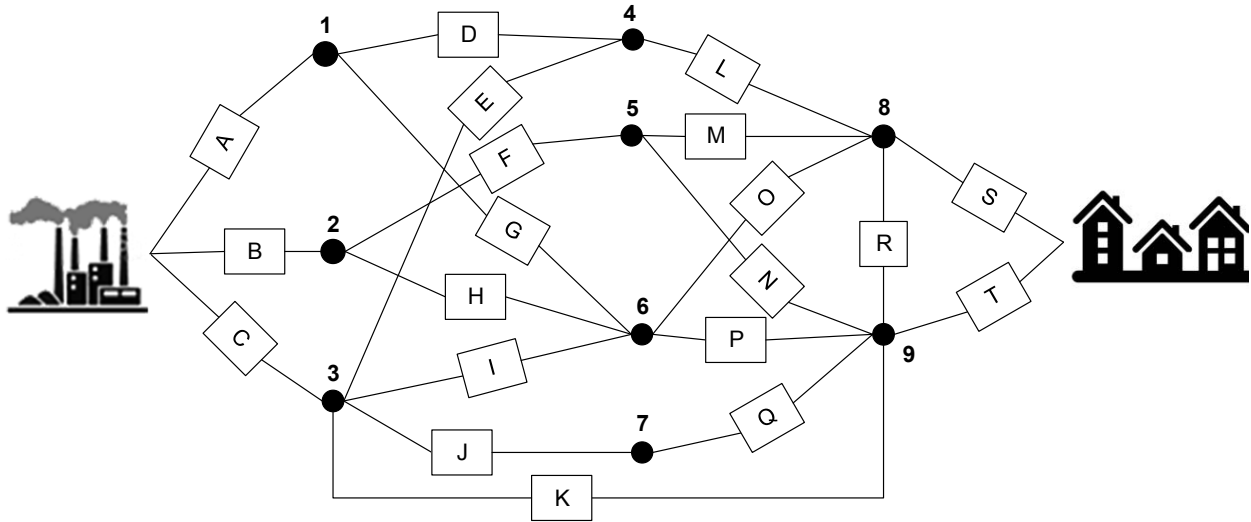

Figure 4. All possible transition line and potential substation.

TABLE II. FEATURE OF TRANSMISSION LINE BETWEEN SUBSTATIONS

r_{min} c_{min}	r_{max} f	start	1	2	3	4	5	6	7	8	9	end
start	---	---	---	---	---	---	---	---	---	---	---	---
1	---	0.9 2	0.992 0.55	---	---	---	---	---	---	---	---	---
2	---	---	---	---	---	---	---	---	---	---	---	---
3	---	---	---	---	---	---	---	---	---	---	---	---
4	---	---	---	---	---	---	---	---	---	---	---	---
5	---	---	---	---	---	---	---	---	---	---	---	---
6	---	---	---	---	---	---	---	---	---	---	---	---
7	---	---	---	---	---	---	---	---	---	---	---	---
8	---	---	---	---	---	---	---	---	---	---	---	---
9	---	---	---	---	---	---	---	---	---	---	---	---
end	---	---	---	---	---	---	---	---	---	---	---	---

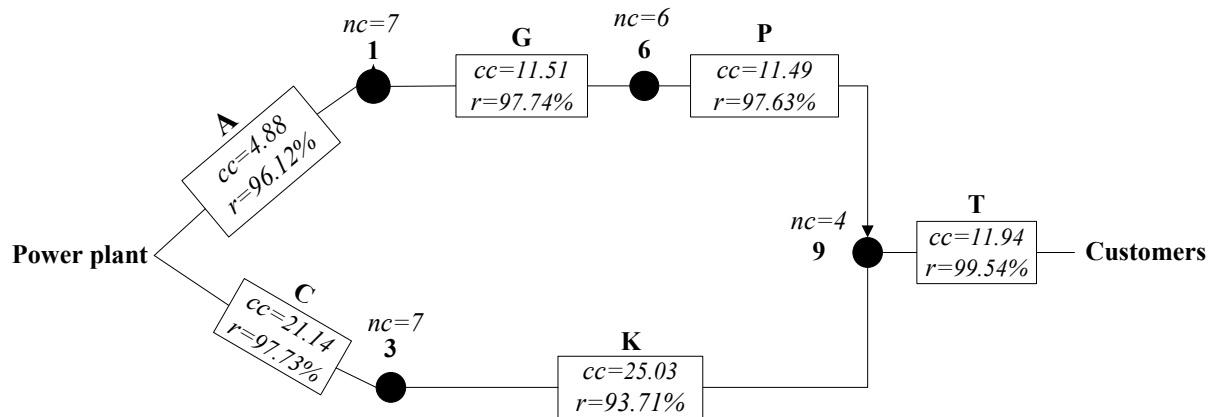

Figure 5. Optimal solution by proposed algorithm

ACKNOWLEDGMENT

This research was supported by MAPNA Group.

REFERENCES

- [1] M. Modarres, M. P. Kaminskiy, and V. Krivtsov, *Reliability engineering and risk analysis: a practical guide*. CRC press, 2016.
- [2] A. K. Verma, S. Ajit, and D. R. Karanki, "Reliability of Complex Systems," in *Reliability and Safety Engineering* London: Springer London, 2016, pp. 123-159.
- [3] A. Manju, A. Sudhanshu, and S. V. K., "Optimal redundancy allocation in complex systems," *Journal of Quality in Maintenance Engineering*, vol. 16, no. 4, pp. 413-424, 2010.
- [4] E. Zio, *The Monte Carlo simulation method for system reliability and risk analysis*. Springer, 2013.
- [5] X. G. Chen, "A novel reliability estimation method of complex network based on Monte Carlo," *Cluster Computing*, journal article vol. 20, no. 2, pp. 1063-1073, June 01 2017.
- [6] W. Kuo and R. Wan, "Recent Advances in Optimal Reliability Allocation," in *Computational Intelligence in Reliability Engineering: Evolutionary Techniques in Reliability Analysis and Optimization*, G. Levitin, Ed. Berlin, Heidelberg: Springer Berlin Heidelberg, 2007, pp. 1-36.
- [7] R. Soltani, "Reliability optimization of binary state non-repairable systems: A state of the art survey," *International Journal of Industrial Engineering Computations*, vol. 5, no. 3, pp. 339-364, 2014.
- [8] G. Levitin, *Computational intelligence in reliability engineering: evolutionary techniques in reliability analysis and optimization*. Springer Science & Business Media, 2006.
- [9] D. W. Coit and A. E. Smith, "Reliability optimization of series-parallel systems using a genetic algorithm," *IEEE Transactions on Reliability*, vol. 45, no. 2, pp. 254-260, 1996.
- [10] B. Dengiz, F. Altıparmak, and A. E. Smith, "Local search genetic algorithm for optimal design of reliable networks," *IEEE Transactions on Evolutionary Computation*, vol. 1, no. 3, pp. 179-188, 1997.
- [11] M. Agarwal and R. Gupta, "Genetic search for redundancy optimization in complex systems," *Journal of Quality in Maintenance Engineering*, vol. 12, no. 4, pp. 338-353, 2006.
- [12] M. A. Farsi and B. K. Jahromi, "Reliability allocation of a complex system by genetic algorithm method," in *2012 International Conference on Quality, Reliability, Risk, Maintenance, and Safety Engineering*, 2012, pp. 1046-1049.
- [13] I. B. Gertsbakh and Y. Shpungin, *Models of network reliability: analysis, combinatorics, and Monte Carlo*. CRC press, 2016.
- [14] R. Y. Rubinstein and D. P. Kroese, *Simulation and the Monte Carlo method*. John Wiley & Sons, 2016.
- [15] E. Zio and N. Pedroni, "Reliability Estimation by Advanced Monte Carlo Simulation," in *Simulation Methods for Reliability and Availability of Complex Systems*, J. Faulin, A. A. Juan, S. Martorell, and J.-E. Ramírez-Márquez, Eds. London: Springer London, 2010, pp. 3-39.
- [16] S. Pascual Martínez, B. Otero Calviño, and C. M. Rocco Sanseverino, "All-terminal reliability evaluation through a Monte Carlo simulation based on an MPI implementation," in *Proceedings of PSAM 2011/ESREL 2012*, 2012, pp. 1-6.
- [17] S. Conti and S. A. Rizzo, "Monte Carlo Simulation by Using a Systematic Approach to Assess Distribution System Reliability Considering Intentional Islanding," *IEEE Transactions on Power Delivery*, vol. 30, no. 1, pp. 64-73, 2015.
- [18] S. Faghih-Roohi, M. Xie, and K. M. Ng, "Accident risk assessment in marine transportation via Markov modelling and Markov Chain Monte Carlo simulation," *Ocean Engineering*, vol. 91, pp. 363-370, 2014/11/15/ 2014.
- [19] S. K. Sinha and M. D. Pandey, "Probabilistic Neural Network for Reliability Assessment of Oil and Gas Pipelines," *Computer-Aided Civil and Infrastructure Engineering*, vol. 17, no. 5, pp. 320-329, 2002.
- [20] M. Marseguerra, E. Zio, and L. Podofillini, "Condition-based maintenance optimization by means of genetic algorithms and Monte Carlo simulation," *Reliability Engineering & System Safety*, vol. 77, no. 2, pp. 151-165, 2002/08/01/ 2002.
- [21] W. Yeh, Y. Lin, Y. Y. Chung, and M. Chih, "A Particle Swarm Optimization Approach Based on Monte Carlo Simulation for Solving the Complex Network Reliability Problem," *IEEE Transactions on Reliability*, vol. 59, no. 1, pp. 212-221, 2010.
- [22] M. Marseguerra, E. Zio, and L. Podofillini, "Genetic Algorithms and Monte Carlo Simulation for the Optimization of System Design and Operation," in *Computational Intelligence in Reliability Engineering: Evolutionary Techniques in Reliability Analysis and Optimization*, G. Levitin, Ed. Berlin, Heidelberg: Springer Berlin Heidelberg, 2007, pp. 101-150.
- [23] R. Billinton and R. N. Allan, *Reliability evaluation of power systems*. Springer Science & Business Media, 2013.
- [24] W. L. Billinton, *Reliability Assessment of Electric Power Systems Using Monte Carlo Methods* (Springer Science+Business Media New York). Springer US, 1994.
- [25] G. A. Pagani and M. Aiello, "The Power Grid as a complex network: A survey," *Physica A: Statistical Mechanics and its Applications*, vol. 392, no. 11, pp. 2688-2700, 2013/06/01/ 2013.
- [26] K. R. Anjana and R. S. Shaji, "A review on the features and technologies for energy efficiency of smart grid," *International Journal of Energy Research*, vol. 42, no. 3, pp. 936-952, 2018.
- [27] D. Niyato, P. Wang, and E. Hossain, "Reliability analysis and redundancy design of smart grid wireless communications system for demand side management," *IEEE Wireless Communications*, vol. 19, no. 3, pp. 38-46, 2012.
- [28] Y. Shi, X. Qiu, and S. Guo, "Genetic algorithm-based redundancy optimization method for smart grid communication network," *China Communications*, vol. 12, no. 8, pp. 73-84, 2015.
- [29] M. T. Todinov, *Risk-based reliability analysis and generic principles for risk reduction*. Elsevier, 2006.
- [30] A. Mettas, "Reliability allocation and optimization for complex systems," in *Annual Reliability and Maintainability Symposium. 2000 Proceedings. International Symposium on Product Quality and Integrity (Cat. No.00CH37055)*, 2000, pp. 216-221.