

Enhanced process for energy efficient extraction of 1,3-butadiene from a crude C4 cut

Mantingh, Jeremy; Kiss, Anton A.

DOI

[10.1016/j.seppur.2021.118656](https://doi.org/10.1016/j.seppur.2021.118656)

Publication date

2021

Document Version

Final published version

Published in

Separation and Purification Technology

Citation (APA)

Mantingh, J., & Kiss, A. A. (2021). Enhanced process for energy efficient extraction of 1,3-butadiene from a crude C4 cut. *Separation and Purification Technology*, 267, Article 118656. <https://doi.org/10.1016/j.seppur.2021.118656>

Important note

To cite this publication, please use the final published version (if applicable). Please check the document version above.

Copyright

Other than for strictly personal use, it is not permitted to download, forward or distribute the text or part of it, without the consent of the author(s) and/or copyright holder(s), unless the work is under an open content license such as Creative Commons.

Takedown policy

Please contact us and provide details if you believe this document breaches copyrights. We will remove access to the work immediately and investigate your claim.



Enhanced process for energy efficient extraction of 1,3-butadiene from a crude C₄ cut

Jeremy Mantingh^{a,*}, Anton A. Kiss^{a,b,*}

^a Department of Chemical Engineering, Delft University of Technology, Van der Maasweg 9, 2629 HZ Delft, the Netherlands

^b Department of Chemical Engineering and Analytical Science, The University of Manchester, Sackville Street, Manchester M13 9PL, United Kingdom

ARTICLE INFO

Keywords:

Fluid separation
Process intensification
Process design
Vapor recompression
Energy savings

ABSTRACT

1,3-butadiene is an essential platform chemical for producing rubberlike polymers, which is extracted from C₄ hydrocarbons that are produced through steam cracking. The current state-of-the-art technology is the BASF process that uses thermally coupled extractive distillation (ED) followed by two distillation columns. However, the process requires high temperature heat input, thus high cost hot utility and reduces the possibility for process heat integration.

To solve these issues, this study proposes novel enhancements: the ED part is modified with intermediate heating and the classic columns are replaced with a heat pump assisted dividing wall column (DWC). Rigorous simulations were carried out in Aspen Plus for a typical ED process. The intermediate reboiler system is designed to maximize the possible process heat recovery. The results show that the heat pump assisted DWC is able to reduce the energy intensity of the classic distillation section of the BASF process by 54.8% and reduces the total annual costs by 29.9%. Additionally, the intermediate reboiler reduces the energy intensity of the ED section by 8.3% while also reducing the CAPEX of the system due to the need for a smaller recycle compressor. In combination, these modifications are able to achieve up to a 21% reduction in the energy intensity of the overall process, with a payback time of 1 year.

1. Introduction

1,3-Butadiene is an essential platform chemical that is used to produce many consumer and industrial products, predominantly synthetic rubbers. Over half of its production is used for manufacturing styrene-butadiene rubber and polybutadiene, which are utilized to make tires, adhesives and sealants [44]. In 2015 the production of 1,3-butadiene reached 11 million metric tons with a market valued above 30 billion USD [33].

Butadiene can be synthesized on purpose by dehydrogenation of n-butane, from ethanol, or by catalytic dehydrogenation of normal butenes. Nonetheless, its industrial production is almost entirely as a by-product of ethylene generation via steam cracking processes [44]. This process produces a stream of mixed C₄ hydrocarbons (hereon referred to as the C₄ cut), from which butadiene is extracted before it can be converted to useful products downstream. Due to the close boiling points of the components in the C₄ cut, conventional distillation can not be practically used to achieve the required separation and purification of 1,3-butadiene [3]. However, the difference in the solubility of the

components in polar aprotic solvents, such as N-methyl-2-pyrrolidone (NMP), dimethylformamide (DMF) and acetonitrile (ACN), allows for an effective separation of butadiene by extractive distillation. The affinity for the different hydrocarbons to the polar solvent is directly dependent on the degree of unsaturation, where highly unsaturated hydrocarbons are more soluble [11]. Table 1 lists the components that are present in a typical industrial C₄ cut, including their close boiling points and mass fractions in the C₄ cut [28,37].

There are several industrial technologies for the separation and purification of 1,3-butadiene from a crude C₄ cut, developed by various companies: NMP process (BASF), ACN process (Shell), DMF process (Nippon Zeon), furfural process (Phillips) and dimethylacetamide process (Union Carbide) [38]. They have many similarities, but differ in the mass separating agent used (solvent for ED). Modern plants employ the NMP process or the DMF process [11]. These two particular technologies are superior in their ability to enhance the relative volatility of components in the C₄ cut. The solvents that they employ are the most environmentally friendly (out of the extraction technologies), and the solvents do not form azeotropes with the hydrocarbons which allows for

* Corresponding authors at: Department of Chemical Engineering, Delft University of Technology, Van der Maasweg 9, 2629 HZ Delft, the Netherlands.
E-mail address: TonyKiss@gmail.com (A.A. Kiss).

Table 1
Composition and normal boiling points of components in the C₄ cut.

Component	Chemical Formula	Normal Boiling Point [°C]	Composition [w %]
Propene	C ₃ H ₆	-47.8	2.11×10^{-3}
Propane	C ₃ H ₈	-42.1	1.00×10^{-3}
Propadiene	C ₃ H ₄	-34.5	4.83×10^{-2}
Propyne	C ₃ H ₄	-23.3	6.13×10^{-2}
Isobutane	C ₄ H ₁₀	-11.8	3.54
Isobutene	C ₄ H ₈	-6.8	23.4
1-Butene	C ₄ H ₈	-6.3	6.32
1,3-Butadiene	C ₄ H ₆	-4.4	50.6
n-Butane	C ₄ H ₁₀	-0.4	7.61
Trans-2-Butene	C ₄ H ₈	0.9	3.27
Cis-2-Butene	C ₄ H ₈	3.8	2.58
Vinylacetylene	C ₄ H ₄	5.2	1.91
Ethylacetylene	C ₄ H ₆	8.1	0.36
1,2-Butadiene	C ₄ H ₆	10.9	0.29

easy solvent recovery, unlike the ACN process [1,31,46]. Although the required solvent to feed flowrate ratio in the NMP process is higher than the DMF process, the NMP process has lower energy requirements as a result of the lower operating pressures and temperatures [17]. Fig. 1 shows a simplified flowsheet of the NMP process from BASF that is considered the state-of-the-art technology, on which any process improvements can be considered relevant.

One area of investigation is solvent improvement of the extractive distillation process. The addition of salts to ACN was found to reduce the required solvent flowrate, although the effect of this salt addition on the energy input for solvent regeneration was not reported [24]. The use of ionic liquids as an additive to the ACN process found a 7% reduction in energy consumption, although the main benefit of this novelty was a reduction in ACN losses, which is not an issue for the NMP process due to the low solvent volatility [42]. Adsorptive separation of the C₄ cut is likely to have reduced energy usage as compared to conventional distillation methods, although the adsorption capacity is too low to

compete with distillation in the near future [10,27]. The reactive separation of isobutene from the C₄ cut was also studied, but the formation of by-products in this separation imposes limits on the achievable product purity [34]. The improvement of the NMP process by integrating it with a membrane separation claimed that a reduction in energy use of ~30% was theoretically possible. However, the permeability of many of the components in the C₄ cut were just assumed without validation, and the initial energy use of the NMP process that the study reports ($4.2 t_{\text{Steam}}/t_{1,3\text{-butadiene}}$) is above the typical industrial range (about 1.5–2.5 $t_{\text{Steam}}/t_{1,3\text{-Butadiene}}$) [3,30]. The energy use of the distillation section of the DMF process, which is similar to that of the NMP process, was reduced by 22% by changing the order of the distillation columns [25]. However, this modification requires that the final 1,3-butadiene product comes from a reboiler (not a condenser), which runs the risk of thermal degradation and impurities.

A key feature of extractive distillation is that the extraction solvent has a low volatility such that it can be easily regenerated for reuse [19–20,35]. However, this means that the operating temperatures of the process are higher than they would be in the absence of solvent. The NMP process is highly thermally coupled which can result in low total energy use for the separation. However, thermally coupling typically requires heat at a higher temperature than in the de-coupled case [4]. The large temperature span across thermally coupled ED columns can require a higher grade of heating utility and reduce the opportunity for process heat integration, which can increase overall energy usage and operating costs [45,47]. Considering this, there is a research gap and an opportunity to improve the NMP process if heat can be input at a lower temperature such that the high temperature utility usage is reduced. Moreover, the separation of components in the C₄ cut (after ED) by conventional distillation is highly inefficient as a result of the close boiling points – see Table 1, [3]. However, the NMP process still employs two conventional distillation columns to extract propyne and to purify the final 1,3-butadiene product, which is an inefficient separation that could be significantly enhanced.

Heat pump assisted distillation is a promising technology to separate

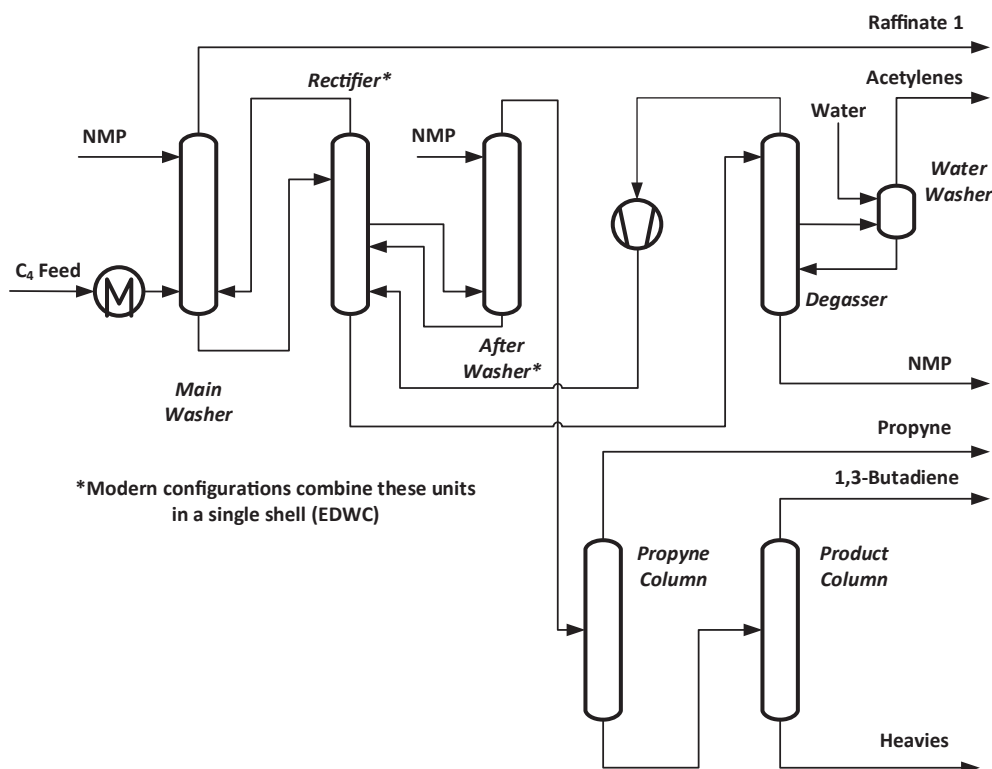

Fig. 1. Simplified process flow scheme of the NMP process.

a component mixture while using less energy than classic distillation [14]. Distillation can be considered as a heat engine, as heat is supplied at high quality to the reboiler and rejected at low quality from the condenser, while work is output in the form of a separation of components. In case of close boiling components, this is an inefficient heat engine, which presents an opportunity for efficient heat pumping. The main heat pump assisted distillation systems are based on using mechanical heat pumps (including bottom flashing, vapor recompression and external heat pumping) or absorption heat pumps in sequential or parallel operation [14,16]. Of these systems, vapor recompression has gained the most attention as a result of its simplicity and efficiency [16].

To enhance further extractive distillation processes, which are typically energy intensive, double effect heat integration, intermediate reboiler and heat pumps have been explored [12]. The applicability of double effect heat integration reduces for large numbers of columns in the extraction system, which limits its feasibility for 1,3-butadiene extraction [12]. Heat pump systems are efficient when the temperature of the reboiler and condenser are similar (hence requiring a low temperature lift), but this not the case for extractive distillation systems where the solvent has a much higher boiling point than the component mixture. Because of the high boiling-point solvent, high quality hot utility is often needed for extractive distillation and this means high OPEX. Intermediate reboiler technology allows for lower quality utilities to be used, which can reduce operating costs [12,47]. For example, the total annual costs of separating benzene/cyclohexane are reduced by 19% using intermediate reboiler technology [26].

The novelty of this paper consists in a much improved version of the NMP process that makes use of several key features: 1) intermediate heating to enhance the heat integration potential of the ED process, resulting in lower overall energy use and operating costs; 2) a single dividing wall column (DWC) instead of the current conventional distillation sequence, to separate propyne and to purify the final 1,3-butadiene product more effectively; and 3) addition of a vapor recompression cycle to assist the DWC in order to improve its energy efficiency. The novel butadiene extraction process was rigorously simulated in Aspen Plus, along with the state-of-the-art conventional NMP process (as reference case), for a processing capacity of 187 kta mixed C₄ feed to produce 94 kta 1,3-butadiene product.

2. Problem statement

In the conventional NMP process for the extraction of 1,3-butadiene from the C₄ cut, a crude (97–99 w%) butadiene stream is produced from a series of thermally coupled ED columns [17,41,43]. As a result of this, a large proportion of the heat input to the process is via the degasser column at a temperature higher than any other point in the process – see Fig. 1. This high temperature heat input results in a limited opportunity for heat integration within the process, which results in high energy use and operating costs. Particularly for the NMP process, the large feed to solvent flowrate (F/S) ratio provides a large amount of excess heat that is rejected when the regenerated solvent is cooled to be recycled. Instead of supplying all of the heat at high temperature, it would be better to use intermediate heating to supply heat to the process such that the waste heat available from the solvent cooling (or elsewhere), can be used for the separation to reduce the energy use and operating costs of the overall process. Furthermore, the crude butadiene that is obtained from the ED columns is further purified in a series of distillation columns, which is an energy inefficient separation due to the close boiling points of the key components. Instead of supplying heat via hot utility to the reboiler of each column and rejecting heat to cooling water at the condensers, it would be better to upgrade the waste heat to a higher temperature via a heat pump and use that to drive the reboiler. Moreover, combining the two distillation columns into a single DWC unit that is assisted by the vapor recompression heat pump can reduce the required OPEX and CAPEX as compared to the two conventional columns.

Table 2

Binary NRTL interaction parameters for systems containing NMP (as component j).

Component i	a _{ij}	a _{ji}	b _{ij}	b _{ji}	α _{ij}	Source
1,3-Butadiene	0	0	656.607	−176.935	0.3	APV88 VLE-RK
n-Butane	0	0	634.884	145.05	0.3	UNIFAC
i-Butane	0	0	635.217	143.841	0.3	UNIFAC
1-Butene	0	0	689.515	63.7335	0.3	User
i-Butene	0	0	689.515	63.7335	0.3	APV88 VLE-RK
Trans-2-Butene	0	0	635.533	66.7867	0.3	User
Cis-2-Butene	0	0	635.533	66.7867	0.3	APV88 VLE-RK
Water	7.2111	−2.0976	487.597	−2218.79	0.3	APV88 VLE-RK

Table 3

Comparison between simulated results and plant data reported in literature [17,43]

Stream	Component	Simulated Result [w %]	Plant Data [w %]
Main Washer	1,3-Butadiene	0.2	0.2
	i-Butene	50.1	50.0
After Washer	1,3-Butadiene	98.4	99.1
	Ethylacetylene	0.0	0.0
Final Product	Vinylacetylene	0.0	0.0
	1,3-Butadiene	99.7	99.7
	i-Butene	0.01	0.05
	Trans-2-Butene	0.1	0.2
	Cis-2-Butene	0.2	0.2

3. Process simulation approach

3.1. Thermodynamics data

When selecting a physical property model, the presence of polar components is an important consideration [5]. In the case of the NMP process, the polar NMP solvent requires a property model that accounts for the non-ideality induced by this polarity, such as an activity coefficient model. However, the absence of polar NMP in the distillation section of the process makes an equation of state that is typical for modelling hydrocarbon systems a more appropriate choice [7]. The non-random two liquid (NRTL) activity coefficient method paired with the Redlich-Kwong (RK) equation of state have been used in previously reported simulations of the extractive sections of the NMP process to give a good approximation of an industrial NMP process [17,43]. Thus the NRTL-RK property model is used for the extractive distillation sections of the process, while the Peng-Robinson equation of state is used to model the simple distillation section.

Binary interaction parameters are available to a limited extent in the Aspen Plus databanks for the C₄/NMP system, while the missing interaction parameters are estimated with the UNIFAC group contribution method. An important set of interaction parameters are those of the C₄ components with the NMP solvent, as the affinity for each of the components in the solvent is the principle behind the ED process. After an initial simulation following reported process specifications, the quantity of 1-butene and *trans*-2-butene passing to the distillation section was slightly higher than the literature reports [2,17,18,41,43]. To resolve this, the interaction parameters between 1-butene/NMP and *trans*-2-butene/NMP (initially estimated by UNIFAC) were adjusted such that *cis*-2-butene is indeed the light key component of the ED section. Table 2 provides the key interaction parameters between NMP and the C₄ hydrocarbons.

The property model was validated against literature data (including

Table 4
Process design specifications for the NMP process.

Description	Specification
1,3-Butadiene Recovery	≥98%
1,3-Butadiene in Raffinate 1	≤0.2 w%
1,3-Butadiene Product Purity	≥99.7 w%
Acetylenes in Product	≤20 ppm

Table 5
Configurations of the extractive distillation columns – see flowsheet in Fig. 1.

	Main Washer	Rectifier	After Washer	Degasser	Water Washer
No. Stages	26	30	36	11	2
Pressure [bar]	4.50	4.54	4.50	1.52	1.52
Feed Stage	26	–	36	1	2
Solvent Feed Stage	2	–	6	–	1
Side Stream Stage	–	24	–	7	–
Heat Duty [MW]	–	9.85	–	12.06	–

industrial plant data), as shown in Table 3 [17,43]. Component-solvent binary interaction parameters that were estimated with the UNIFAC model (namely acetylenes and butanes) are given particular scrutiny, but are found to be in good agreement with industrial data, whereby butanes are completely removed in the main washer column and acetylenes are almost completely removed before the butadiene leaves the after washer column [17].

3.2. Process simulation data

This work considers a plant with a processing capacity of 187 kta mixed C₄ feed to produce 94 kta 1,3-butadiene product. The plant is assumed to operate for 8200 h y⁻¹. The composition of the C₄ cut can vary significantly depending on the conditions of the upstream cracking reaction [11]. Typically, the quantity of 1,3-butadiene is between 35 and 55 w% [3]. Table 1 provides the composition of a feed to an existing industrial NMP process as reported in literature [37]. This composition is within the typical C₄ cut ranges, containing 50.6 w% 1,3-butadiene and is used for this study. The quality specifications for the final 1,3-

Table 6
Simulated mass balance for the conventional NMP process flowsheet.

Stream	1	2	3	4	5	6	7	8	9	10	11
	C4 Feed	NMP 1	Raffinate 1	NMP 2	Water	Acetylenes	Waste Water	Regen Solvent	Propyne	1,3-Butadiene	Heavies
Temperature [°C]	30.0	40.0	40.7	40.0	30.0	44.9	44.9	40.0	34.0	38.8	44.9
Pressure [bar]	5.3	5.0	4.5	5.0	1.6	1.5	1.5	1.5	7.0	4.2	4.6
Mass Flow [kg/h]	22,824	251,000	10,660	8000	1500	522	1236	259,217	28	11,419	243
Mass Fraction											
Propane	21 ppm		45 ppm								
Propylene	100 ppm		214 ppm								
Propyne	613 ppm		43 ppm			32 ppm	1 ppm		0.473	5 ppm	
Propadiene	483 ppm					0.002	801 ppm	39 ppb	0.316	3 ppb	
n-butane	0.076		0.163			4 ppb			18 ppm	79 ppm	14 ppm
i-butane	0.035		0.076						593 ppb	86 ppb	
1-butene	0.063		0.135						11 ppm	17 ppm	900 ppb
i-butene	0.234		0.501			1 ppb			42 ppm	62 ppm	3 ppm
trans-2-butene	0.033		0.069			336 ppb	1 ppb		21 ppm	866 ppm	0.013
cis-2-butene	0.026		0.050			3 ppm	13 ppb		22 ppm	0.002	0.124
1,3-butadiene	0.506		0.002			0.042	165 ppm		0.211	0.997	0.473
1,2-butadiene	0.003					0.024	0.035	39 ppm			
ethylacetylene	0.004					0.142	0.006	54 ppb	115 ppb	13 ppm	0.003
vinylacetylene	0.019					0.767	0.028	2 ppm	25 ppb	2 ppm	165 ppm
NMP		0.917	6 ppm	0.917		106 ppb	374 ppm	0.916			
Water		0.083	0.004	0.083	1.000	0.023	0.929	0.084	228 ppb	23 ppm	0.388

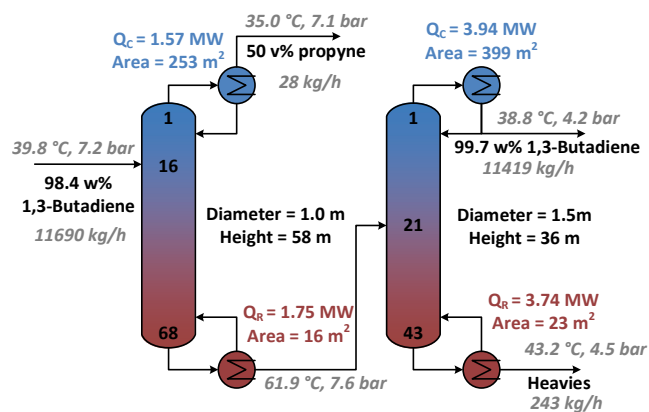

Fig. 2. Configuration of the propyne and product conventional distillation columns.

butadiene product matches the one required for polymerization. Table 4 lists the main process specifications [3]. An additional process specification is that the concentration of propyne in the top of the propyne column must not exceed 50 v% [18]. The rigorous RADFRAC model in Aspen Plus is used to simulate each of the distillation columns in the processes described hereafter.

4. Results and discussion

4.1. BASF process design and simulation

Table 5 shows the design parameters of each of the columns in the state-of-the-art process (number of stages, feed stage, column pressure, duties, etc.) based on the data available in the literature [18]. The recycle flowrate from the degasser column to the rectifier column is selected such that the heat duty of the rectifier reboiler can be completely recovered through process heat integration, which is the case in the NMP process from BASF [18,41]. A large solvent to feed flowrate ratio is a notable feature of the NMP process; a typical value of S/F = 11 is used in this work considering 91.7 w% NMP in water and this stream is recycled [18]. The mass balance and stream information from the simulation of the conventional NMP process (shown in Fig. 1) is given in Table 6.

Fig. 2 shows the configuration of the distillation section of the NMP process from BASF. The configuration of the two conventional distillation columns was determined by performing sensitivity studies on the effect of the number of stages and the feed stage on the total annual costs (TAC). The column pressures are as reported in the patent literature [18]. The final configuration is selected such that the TAC is minimized. To calculate the shell cost, the column height is required. The number of actual trays in each column is calculated from the number of equilibrium stages and using an overall column efficiency determined by the O'Connell correlation [9]:

$$\eta_{Overall} = 0.503(\mu_L \alpha)^{-0.226} \quad (1)$$

where μ_L is the liquid viscosity [mPa s^{-1}] and α is the average relative volatility. A tray spacing of 0.61 m is used to calculate the shell height, along with an additional 2 m of height to allow for liquid distribution and vapor disengagement [40]. This height, along with the diameter that is calculated by Aspen Plus is used to determine the shell and trays investment costs through the following equations [20]:

$$\text{Column Shell Installed Cost(\$)} = \frac{M\&S}{280} \times (957.9 \times d^{1.066} \times H^{0.802}) \times (2.18 + F_P) \quad (2)$$

$$\text{Column Trays Installed Cost(\$)} = \frac{M\&S}{280} \times 97.2 \times d^{1.55} \times H \quad (3)$$

$$F_P = 1 + 0.0074(P - 3.48) + 0.00023(P - 3.48)^2 \quad (4)$$

where M&S denotes the Marshall and Swift cost index (with a value of 1638.2 at the end of 2018), d is the column diameter (m) and h is the column height (m). The pressure factor (F_P) is calculated from the column pressure (P) in bar. The overall heat transfer coefficients (U) for the condensers and reboilers are assumed to be typical values of $750 \text{ W m}^{-2} \text{ K}^{-1}$ and $1150 \text{ W m}^{-2} \text{ K}^{-1}$ respectively [36]. These coefficients are used with the next equations to calculate the investment costs of the heat exchange units [20]:

$$\text{HeatExchangerInstalledCost(\$)} = \frac{M\&S}{280} \times 474.7 \times A^{0.65} \times 2.29 \quad (5)$$

$$A = \frac{Q}{U \times \text{LMTD}} \quad (6)$$

where Q is the duty [kW], A is the area [m^2] and LMTD the logarithmic mean temperature difference [$^{\circ}\text{C}$]. Saturated low pressure (LP) steam is assumed to be available at 160°C at a cost of $\$7.78 \text{ GJ}^{-1}$ and cooling water at a cost of $\$0.4 \text{ GJ}^{-1}$ [15,20]. The investment costs are annualized over three years using an interest rate of 10%.

Process heat integration is a key feature of the low energy requirements of the NMP process [29]. To assess the energy usage of the NMP process, the maximum energy recovery (MER) case with a minimum temperature difference for process-process heat exchange of 10 K is considered. Almost all of the heat that can be recovered to power the process heating requirements comes from the regenerated solvent that is cooled and recycled, although some heat is also available from the degasser vapor, as it is cooled before the compression, and from the acetylenes/water stream that is condensed after leaving the water wash column. The heat input required for the MER case of the NMP process is 12.1 MW. This heat can be supplied with LP steam available at 160°C , which has a latent heat content of 2082 kJ kg^{-1} [13]. The production rate of 99.7 w% 1,3-butadiene is 11.5 ton h^{-1} , so $1.84 \text{ t}_{\text{steam}}/\text{t}_{\text{product}}$ is required (which is on the low side of industrial range). In addition to LP steam, $260 \text{ kWh}/\text{t}_{\text{product}}$ of electricity and $178 \text{ m}^3/\text{t}_{\text{product}}$ of cooling water (supplied at 25°C and returned at 30°C) is required. These utility inputs to the NMP process are in good agreement with the typical ranges that are reported, which indicates that the simulation of the NMP process is a valid representation of the industrial process [3].

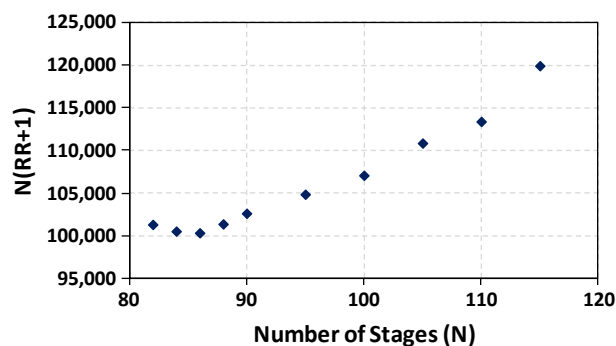

Fig. 3. Determination of the optimum number of stages for the DWC.

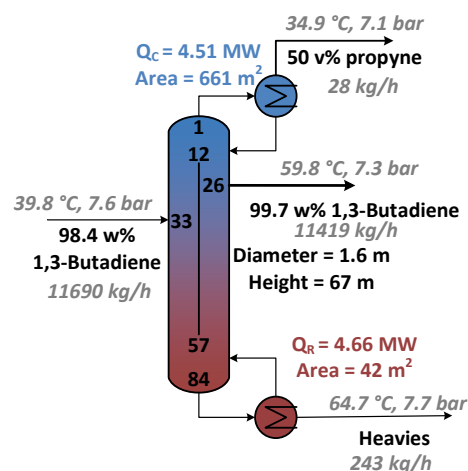

Fig. 4. Configuration of the dividing wall column.

4.2. Heat pump assisted dividing wall column

In a first stage, the distillation section of the NMP process is improved by combining the two classic distillation columns (shown in Fig. 2) into a single unit in the form of a dividing wall column (DWC). The DWC reduces the energy input by minimizing thermodynamically unfavorable remixing effects that occur in the conventional sequence, and reduces investment costs as a result of requiring fewer units [20]. To simulate the DWC, the two column sequence model is used, as described in literature [20]. Starting from an initialized simulation, the DWC design is optimized to minimize the objective function $N(\text{RR} + 1)$ – which is an indirect measure of total annual cost, by combining the size of the column and energy use. For a given number of stages, the vapor and liquid split ratios, feed stage, number of prefractionation stages and prefractionator position are sequentially adjusted. Each sequential adjustment is only made if the separation is improved; if no improvement is seen then no adjustment is made and the next variable is adjusted. The reflux ratio is then reduced for each adjustment until the same degree of separation in the conventional sequence is achieved. The number of stages is systematically reduced while following this procedure until $N(\text{RR} + 1)$ is minimized. The details of this procedure are reported in the literature [8]. The result of the number of stages on this objective function is shown in Fig. 3. Note that the number of stages in this plot includes the condenser (stage 1) and reboiler, hence 84 trays are optimal. Fig. 4 shows the final configuration of the optimal DWC unit.

A mechanical vapor recompression (MVR) cycle is investigated to reduce further the energy input to the distillation section of the NMP process. This type of heat pump uses a single compressor to increase the pressure of the vapor from the top of the DWC, which in turn boosts the

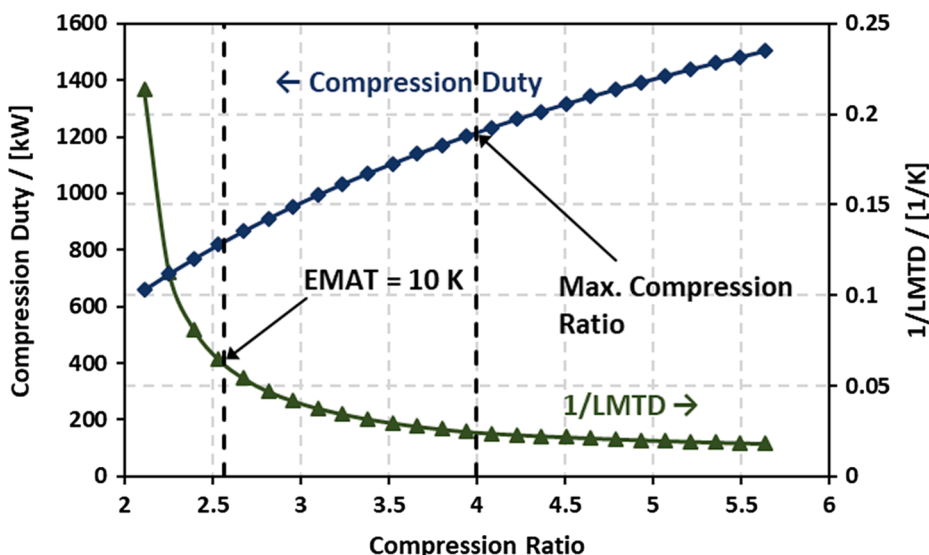

Fig. 5. Dependence of compressor duty and the log mean temperature difference (LMTD) in the dividing wall column’s reboiler on the compression ratio of the MVR system.

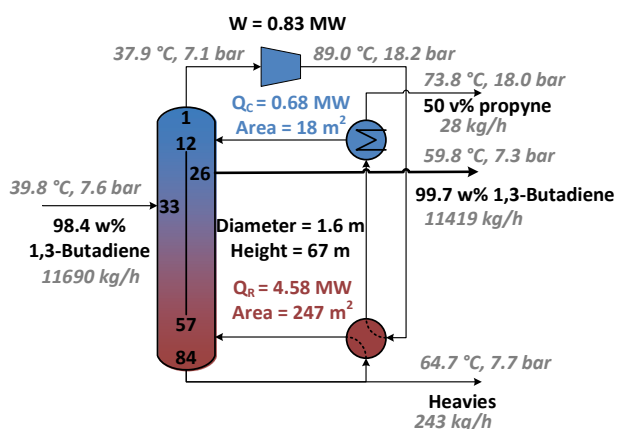

Fig. 6. Configuration of the DWC-MVR system.

temperature. With this higher temperature, the vapor transfers heat to the reboiler of the DWC, which drives the separation. In this way, a large quantity of hot and cold utility input is replaced with a small quantity of electricity input [21]. The use of heat-pump assisted distillation has been shown to be effective when the inverse of the Carnot efficiency is greater than 10, as shown by the following equation [32]:

$$\frac{Q}{W} = \frac{T_C}{T_R - T_C} > 10 \tag{7}$$

For the DWC shown in Fig. 4, the inverse Carnot efficiency is 10.3. Hence, an inefficient heat engine presents an opportunity for efficient heat pumping. The choice of compression ratio presents a trade-off in the DWC-MVR system. A higher compression ratio requires more compression duty, which increases the investment and operating costs of the compressor, so this should be minimized. However, a higher compression ratio also gives a higher discharge temperature, which increases the temperature driving force for heat exchange and hence reduces the heat exchanger surface area and investment costs and hence should be maximized. Fig. 5 shows the effect of increasing compression ratio on the inverse logarithmic mean temperature difference (1/LMTD) and compression duty. There are practical constraints that limit the choice of compression ratio. The heat exchanger equipment presents a practical limitation in that the exchanger minimum approach temperature (EMAT) cannot be too low. Some advanced types of heat exchanger can handle an EMAT as low as 1 K, but more typical equipment types (such as a shell-and-tube heat exchanger) are limited to 10 K, which sets a lower limit [40]. The upper limit is either set by the maximum compression ratio that is achievable in a single stage (which is up to 4), or by a safety limitation that restricts the discharge temperature to 150 °C [22]. In the design proposed here, the lower limit is used to minimize the compression duty and hence minimize the energy input.

Fig. 6 shows the configuration and technical performance of the DWC-MVR system. The investment costs of the compressor are calculated as follows [20]:

$$\text{Compressor Cost}(\$) = \frac{\text{M\&S}}{280} \times 664.1 \times P^{0.82} \times 1.15 \tag{8}$$

where P is the compression duty [kW]. Electricity is assumed available at a cost of \$16.8 GJ⁻¹.

The CO₂ emissions are calculated using the following equations, considering a heat input through LP steam, while an emission factor of 0.556 (kg CO₂) kWh⁻¹ is used for electricity [6,23].

$$Q_{\text{fuel}} = \frac{Q_{\text{steam}}}{\lambda_{\text{steam}}} \times (h_{\text{steam}} - 419) \times \left(\frac{T_{\text{FTB}} - T_0}{T_{\text{FTB}} - T_{\text{stack}}} \right) \tag{9}$$

$$\text{CO}_2 = \left(\frac{Q_{\text{fuel}}}{\text{NHV}} \right) \times C \times \alpha \tag{10}$$

Table 7
Process comparison in terms of key performance indicators for the heat pump assisted dividing wall column system.

Key Performance Indicator	Classic	DWC	Savings	DWC-MVR	Savings
Total Investment Costs [k\$]	1330	1200	9.8%	2201	-65.4%
Total Operating Costs [k\$/yr]	1325	1124	15.2%	418	68.4%
Total Annual Costs [k\$/yr]	1860	1606	13.6%	1303	29.9%
CO ₂ Emissions [kg CO ₂ /ton product]	69.3	58.9	15.1%	40.3	41.9%
Thermal Energy Use [kWh/kg product]	0.48	0.41	15.1%	-	-
Electrical Energy Use [kWh/kg product]	-	-	-	0.07	-
Equivalent Energy Requirements [kWh/kg]	0.48	0.41	15.1%	0.22	54.8%

where the latent heat of steam (λ_{steam}) and the saturated steam enthalpy (h_{steam}) are determined from steam tables, while the flame temperature (T_{FTB}) is assumed to be 1300 °C, the stack temperature (T_{stack}) 200 °C and the ambient temperature (T_0) 25 °C. The fuel is assumed to be natural gas, with a net heating value (NHV) of 48.9 MJ kg⁻¹, a carbon content (C) of 0.41 kg carbon (kg_{fuel})⁻¹ and molar mass ratio between CO₂ and C of 3.67 [23]. Electricity is considered to be sourced from fossil fuel (grey electricity), and the equivalent energy (primary thermal energy required to produce the electricity) is assumed to be 3 times the electrical energy input [22]. This represents the worst-case scenario, as with renewable electricity both the CO₂ emissions and equivalent energy value is lower.

Table 7 provides the results in terms of key performance indicators for the DWC and DWC-MVR systems, as compared to the conventional case. The DWC reduces energy usage by 15.1%, which results in a reduction in total operating costs (TOC) due to reduced LP steam and cooling water use. In addition, the investment costs of the DWC are 9.8% lower than the conventional sequence due to the DWC having only one shell and two heat exchangers, as compared to the two shells and four heat exchangers of the conventional system (see Fig. 2 and Fig. 4 for the size of units). The DWC-MVR system gives significant energy savings of 54.8% as compared to the conventional sequence. Although the energy input of the DWC-MVR is electricity (which is higher value than LP steam), the operating costs are reduced by 68.4% due to this large energy reduction. The investment costs of the compressor are significant (1.1 M\$), and the total investment cost (TIC) is higher than the conventional case. However, this additional investment is worthwhile as indicated by the reduced total annual costs (TAC) of the DWC-MVR system, as this leads to a payback time of 1 year or less.

4.3. Extractive distillation with intermediate reboiler

The NMP process uses thermally coupled columns with a low volatility solvent, which requires a hot utility with higher temperature than if conventional distillation columns were used. Using an intermediate reboiler (IR) is an option worth exploring as it can shift some of this high temperature heat input to a lower temperature, which is economically beneficial if a cheaper utility can then be used or if the IR duty can be recovered by process heat integration.

The performance of an intermediate reboiler depends on its position. The closer it is to the base of the distillation column, the better the separation but the higher the temperature of the required heat input (hot utility or process heat integration). If the temperature of the IR is above the process pinch temperature, the IR cannot recover additional heat through process heat integration compared to the original process. In the case of the NMP process, the pinch stream is the bottoms of the rectifier column (being heated and vaporized), so placing the IR on the rectifier column ensures that it operates below the pinch temperature. An upper limit on the position of the IR is imposed by the large vapor side stream that flows to the after washer column. Above this side stream, the column vapor flow is much lower which limits the effectiveness of the IR compared to if it were placed below this side stream. The IR is placed on the stage below the side stream to minimize the temperature and hence maximize the possibility for process heat integration.

The duty of the IR is increased and the vapor recycle from the degasser back to the rectifier is reduced while maintaining the same separation performance. The duty of the rectifier reboiler is maintained such that it is completely powered through process heat integration at all times. This reduces the high quality heat input (LP steam) to the degasser and also reduces the compression duty of the recycle gas compressor. The duty of the IR is increased until a new process pinch is formed. At the formation of the new pinch, no more heat can be recovered to the IR reboiler by process heat integration, so further increasing the duty of the intermediate reboiler would require hot utility. This new pinch can be seen in Fig. 7, which shows the grand

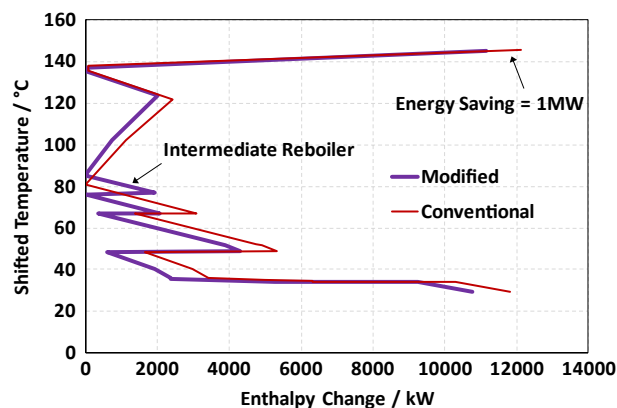

Fig. 7. Grand composite curves for the conventional NMP process and the process with intermediate heating on the rectifier column.

Table 8

Results of the maximum energy recovery heat exchanger networks.

Key Performance Indicator	Conventional	IR Modified
Hot Utility [MW]	12.1	11.2
Cold Utility [MW]	11.8	10.8
Number of Units	19	25
Total Heat Exchange Area [m ²]	2578	2661
Operating Costs [M\$/y]	2.92	2.69
Capital Costs [M\$]	1.07	1.17

Table 9

Process comparison in terms of key performance indicators for the intermediate reboiler modified process.

Key Performance Indicator	Conventional	IR Modified	Saving/ %
HEN Investment Costs [k\$]	1067	1166	-9.3
Compressor Investment Costs [k\$]	2379	2173	8.7
Total Operating Costs [k\$/yr]	3330	3055	8.2
Total Annual Costs [k\$/yr]	4716	4398	6.7
CO ₂ Emissions [kg CO ₂ /ton product]	190	174	8.4
Thermal Energy Use [kWh/kg product]	1.06	0.98	7.9
Electrical Energy Use [kWh/kg product]	0.07	0.06	10.4
Equivalent Energy Requirements [kWh/kg]	1.28	1.17	8.3

composite curve for the conventional NMP process from BASF and for the modified case proposed in this work (considering 10 K EMAT). The effect of this IR is that the overall process hot utility need is reduced by 1 MW. In addition, the electricity usage is reduced by 0.1 MW due to the reduced recycle flowrate. A maximum energy recovery heat exchanger network is developed for the conventional case and the modified case, with the results of these networks given in Table 8. Due to the complexity of the modified case, the cost of this network is higher. However, the cheaper compressor (206 k\$ saving) outweighs the heat exchanger network cost increase (99 k\$ increase), giving a net reduction in investment costs of 106 k\$. The energy savings are directly reflected in the operating costs, which are proportionally reduced. Table 9 gives an overview of the conventional vs intermediate reboiler systems, showing improved key performance indicators for the IR system.

4.4. Sustainability metrics

Among the sustainability metrics that can be evaluated for this industrial process, the most relevant ones are the energy intensity, water consumption and greenhouse gas (GHG) emissions [39]. Energy is input to the process through LP steam and electricity, water is consumed in the

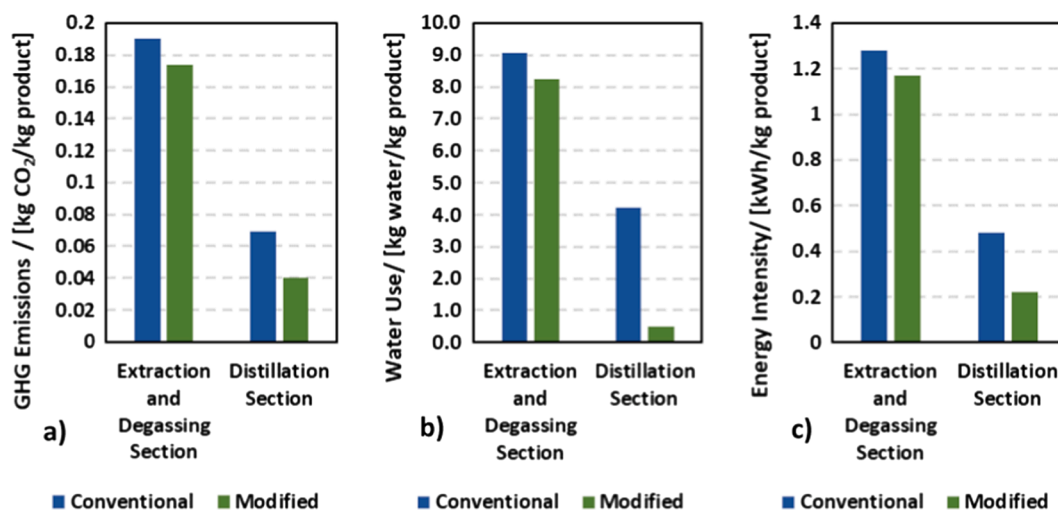

Fig. 8. Effect of the process modifications on the: (a) GHG emissions, (b) water consumption, and (c) energy intensity.

process through LP steam and cooling water, and GHG emissions are from CO₂ used to generate the energy inputs (worst-case scenario with grey electricity). The water consumption is calculated assuming that 10% of the LP steam and cooling water is removed as blowdown and replaced with fresh water, and that cooling water is supplied at 20 °C and returned at 30 °C. Fig. 8 shows the effect of the newly proposed process modifications on the sustainability metrics. Each of the modifications in both sections of the process brings a reduction that indicates they are indeed sustainable design changes.

5. Conclusions

This work proposed several key improvements to the state-of-the-art 1,3-butadiene extraction process by BASF, and successfully proved the advantages of an energy efficient combination of mechanical vapor recompression and DWC technology and a thermally coupled extractive distillation assisted by intermediate heating. In this configuration, the top vapor of the DWC is compressed from 7.1 to 18.2 bar to increase its temperature and is used to drive the reboiler of the DWC. In addition, the excess heat that is available from the solvent recycle cooler is used to drive an intermediate reboiler of the rectifier column to reduce the process hot utility use.

The results show that that the specific energy requirements are reduced from 1.28 to 1.17 kWh/kg for the ED process with IR heating, achieving 8.3% energy savings over the classic ED process. If LP steam is used in the propyne and product columns of the classic sequence, the novel DWC-MVR system reduces the specific energy requirements from 0.48 to only 0.22 kWh/kg product. Combining all these process modifications brings up to 21% energy savings in total as compared to the conventional process from BASF. The overall specific steam use of the modified process is reduced from 1.84 to 1.69 t_{steam}/t_{1,3-Butadiene}. These modifications are economically feasible, with the intermediate reboiler reducing the investment costs of the process by 107 k\$ and the DWC-MVR system having a simple payback time of just one year.

Besides the improved economics, the enhanced process proposed in this work revealed major improvements in the sustainability metrics: GHG emissions of 0.21 kg CO₂e/kg product (17% reduction), water consumption of 8.8 kg H₂O/kg product (34% reduction), and an overall energy intensity of 1.38 kWh/kg product (5.0 MJ/kg product; equivalent to 21% reduction).

6. Author statement

All persons who meet authorship criteria are listed as authors, and all authors certify that they have participated sufficiently in the work to

take public responsibility for the content, including participation in the concept, design, analysis, writing, or revision of the manuscript. Furthermore, each author certifies that this material or similar material has not been and will not be submitted to or published in any other publication.

CRedit authorship contribution statement

Jeremy Mantingh: Conceptualization, Methodology, Software, Data curation, Validation, Visualization, Writing - original draft, Writing - review & editing. **Anton A. Kiss:** Conceptualization, Methodology, Formal analysis, Investigation, Resources, Visualization, Validation, Supervision, Project administration, Writing - review & editing.

Declaration of Competing Interest

The authors declare that they have no known competing financial interests or personal relationships that could have appeared to influence the work reported in this paper.

Acknowledgement

AAK gratefully acknowledges the Royal Society Wolfson Research Merit Award (No. WM170003).

References

- [1] C.M. Alder, J.D. Hayler, R.K. Henderson, A.M. Redman, L. Shukla, L.E. Shuster, H. F. Sneddon, Updating and further expanding GSK's solvent sustainability guide, *Green Chem.* 18 (13) (2016) 3879–3890, <https://doi.org/10.1039/c6gc00611f>.
- [2] Bohner, G., Kindler, K., Pahl, M., & Kaibel, G., 2006. Method and device for obtaining 1,3 pure butadiene from 1,3 crude butadiene by distillation (Patent No. US 7,132,038 B2). <https://patents.google.com/patent/US7132038B2/en>.
- [3] R. Brummer, BASF Butadiene Extraction Technology, in: R.A. Meyers (Ed.), *Handbook Of Petrochemicals Production Processes*, McGraw-Hill Education, 2005, pp. 95–109.
- [4] J.A. Caballero, Thermally coupled distillation, *Comput. Aided Chem. Eng.* 27 (C) (2009) 59–64, [https://doi.org/10.1016/S1570-7946\(09\)70230-5](https://doi.org/10.1016/S1570-7946(09)70230-5).
- [5] E.C. Carlson, Don't gamble with physical properties for simulations, *Chem. Eng. Prog.* 92 (10) (1996) 35–46.
- [6] CO2emissiefactoren., 2020. Lijst emissiefactoren | CO2 emissiefactoren. Lijst Co2-Emissiefactoren. <https://www.co2emissiefactoren.nl/lijest-emissiefactoren/>.
- [7] Danesh, A. (Ed.). (1998). Equations of state. In *Developments in Petroleum Science* (Vol. 47, Issue C, pp. 129–166). Elsevier. [https://doi.org/10.1016/S0376-7361\(98\)80026-5](https://doi.org/10.1016/S0376-7361(98)80026-5).
- [8] I. Dejanović, L. Matijasević, Z. Olujić, An effective method for establishing the stage and reflux requirement of three-product dividing wall columns, *Chem. Biochem. Eng. Q.* 25 (2) (2011) 147–157.
- [9] M. Duss, R. Taylor, Predict distillation tray efficiency, *Chem. Eng. Prog.* (2018) 24–30. https://www.aiche.org/sites/default/files/cep/20180724_r.pdf.

- [10] M. Gehre, Z. Guo, G. Rothenberg, S. Tanase, Sustainable Separations of C4-Hydrocarbons by Using Microporous Materials, *ChemSusChem* 10 (20) (2017) 3947–3963, <https://doi.org/10.1002/cssc.201700657>.
- [11] Grub, J., & Löser, E. (2011). Butadiene. In *Ullmann's Encyclopedia of Industrial Chemistry* (pp. 1–24). Wiley-VCH Verlag GmbH & Co. KGaA. https://doi.org/10.1002/14356007.a04_431.pub2.
- [12] J. Gu, X. You, C. Tao, J. Li, Analysis of heat integration, intermediate reboiler and vapor recompression for the extractive distillation of ternary mixture with two binary azeotropes, *Chem. Eng. Process. - Process Intensificat.* 142 (2019), 107546, <https://doi.org/10.1016/j.cep.2019.107546>.
- [13] L. Haar, J.S. Gallagher, G.S. Kell, *NBS/NRC steam tables thermodynamic and transport properties and computer programs for vapor and liquid states of water in SI units*, CRC Press, 1984.
- [14] A.K. Jana, Advances in heat pump assisted distillation column: A review, *Energy Convers. Manage.* 77 (2014) 287–297, <https://doi.org/10.1016/j.enconman.2013.09.055>.
- [15] M. Jobson, Energy Considerations in Distillation, in: A. Górak, E. Sorensen (Eds.), *Distillation: Fundamentals and Principles*, Elsevier Inc., 2014, pp. 225–270, <https://doi.org/10.1016/B978-0-12-386547-2.00006-5>.
- [16] A. Kazemi, A. Mehrabani-Zeinabad, M. Beheshti, Recently developed heat pump assisted distillation configurations: A comparative study, *Appl. Energy* 211 (2018) 1261–1281, <https://doi.org/10.1007/s11814-012-0075-3>.
- [17] Y.H. Kim, S.Y. Kim, B. Lee, Simulation of 1,3-butadiene extractive distillation process using N-methyl-2-pyrrolidone solvent, *Korean J. Chem. Eng.* 29 (11) (2012) 1493–1499, <https://doi.org/10.1007/s11814-012-0075-3>.
- [18] Kindler, K., & Puhl, H., 2002. Method For Separating A C4-hydrocarbon Mixture (Patent No. US 6,337,429 B1). <https://patents.google.com/patent/US6337429B1/en>.
- [19] Kiss, A. A. (2013a). Distillation | Extractive Distillation. Reference Module in Chemistry, Molecular Sciences and Chemical Engineering, December 2013, 0–24. <https://doi.org/10.1016/B978-0-12-409547-2.05949-7>.
- [20] Kiss, A. A., 2013b. *Advanced Distillation Technologies: Design, Control and Applications*. John Wiley & Sons, Ltd. <https://doi.org/10.1002/9781118543702>.
- [21] A.A. Kiss, C.A. Infante Ferreira, *Heat Pumps in Chemical Process Industry. Heat Pumps Chemical Process Industry*, CRC Press (Taylor & Francis Group), 2016, 10.1201/9781315371030.
- [22] Kiss, A. A., Luo, H., & Bildea, C. S. (2015). Energy Efficient Bioethanol Purification by Heat Pump Assisted Extractive Distillation. In *Computer Aided Chemical Engineering* (Vol. 37, pp. 1307–1312). Elsevier B.V. <https://doi.org/10.1016/B978-0-444-63577-8.50063-2>.
- [23] A.A. Kiss, D.J.P.C. Suszwalak, Innovative dimethyl ether synthesis in a reactive dividing-wall column, *Comput. Chem. Eng.* 38 (2012) 74–81, <https://doi.org/10.1016/j.compchemeng.2011.11.012>.
- [24] Z. Lei, H. Wang, R. Zhou, Z. Duan, Solvent improvement for separating C4 with ACN, *Comput. Chem. Eng.* 26 (9) (2002) 1213–1221, [https://doi.org/10.1016/S0098-1354\(02\)00035-2](https://doi.org/10.1016/S0098-1354(02)00035-2).
- [25] Z. Lei, R. Zhou, Z. Duan, Process improvement on separating C4 by extractive distillation, *Chem. Eng. J.* 85 (2–3) (2002) 379–386, [https://doi.org/10.1016/S1385-8947\(01\)00252-2](https://doi.org/10.1016/S1385-8947(01)00252-2).
- [26] L. Li, Y. Tu, L. Sun, Y. Hou, M. Zhu, L. Guo, Q. Li, Y. Tian, Enhanced Efficient Extractive Distillation by Combining Heat-Integrated Technology and Intermediate Heating, *Ind. Eng. Chem. Res.* 55 (32) (2016) 8837–8847, <https://doi.org/10.1021/acs.iecr.6b01152>.
- [27] Mahdi, H. I., & Muraza, O. (2019). An exciting opportunity for zeolite adsorbent design in separation of C4 olefins through adsorptive separation. In *Separation and Purification Technology* (Vol. 221, pp. 126–151). Elsevier B.V. <https://doi.org/10.1016/j.seppur.2018.12.004>.
- [28] P.M. Mathias, J.R. Elliott, A. Klamt, Butadiene purification using polar solvents. Analysis of solution nonideality using data and estimation methods, *Ind. Eng. Chem. Res.* 47 (15) (2008) 4996–5004, <https://doi.org/10.1021/ie070774p>.
- [29] McDermott. (2018). Butadiene Extraction Technology. In *McDermott Technology*. <https://www.cbi.com/getattachment/f8d91886-4916-43d4-a554-ba8201036c9b/Butadiene-Extraction-Technology.aspx>.
- [30] A. Motelica, O.S.L. Bruinsma, R. Kreiter, M. Den Exter, J.F. Vente, Membrane retrofit option for paraffin/olefin separation-a technoeconomic evaluation, *Ind. Eng. Chem. Res.* 51 (19) (2012) 6977–6986, <https://doi.org/10.1021/ie300587u>.
- [31] O.S. Pavlov, S.A. Karsakov, S.Y. Pavlov, Development of processes for C4 hydrocarbons separation and 1,3-butadiene purification, *Theor. Found. Chem. Eng.* 45 (6) (2011) 858–867, <https://doi.org/10.1134/S0040579511050307>.
- [32] Pleşu, V., Bonet Ruiz, A. E., Bonet, J., & Llorens, J. (2014). Simple equation for suitability of heat pump use in distillation. In *Computer Aided Chemical Engineering* (Vol. 33, pp. 1327–1332). Elsevier B.V. <https://doi.org/10.1016/B978-0-444-63455-9.50056-8>.
- [33] G. Pomalaza, P. Arango Ponton, M. Capron, F. Dumeignil, Ethanol-to-butadiene: The reaction and its catalysts, *Catal. Sci. Technol.* 10 (15) (2020) 4860–4911, <https://doi.org/10.1039/d0cy00784f>.
- [34] Z. Qi, K. Sundmacher, E. Stein, A. Kienle, A. Kolah, Reactive separation of isobutene from C4 crack fractions by catalytic distillation processes, *Sep. Purif. Technol.* 26 (2–3) (2002) 147–163, [https://doi.org/10.1016/S1383-5866\(01\)00156-3](https://doi.org/10.1016/S1383-5866(01)00156-3).
- [35] M.R. Resetarits, M.J. Lockett, *Distillation*, in: R.A. Meyers (Ed.), *Encyclopedia of Physical Science and Technology*, (3rd ed., Academic Press, 2003, pp. 547–559, 10.1016/B0-12-227410-5/00182-4.
- [36] W. Roetzel, B. Spang, *C3 Typical Values of Overall Heat Transfer Coefficients*, in: *VDI Heat Atlas*, (2nd ed., Springer, Berlin Heidelberg, 2010, pp. 75–78, 10.1007/978-3-540-77877-6.6.
- [37] R. Saffari, F. Abbasi, F. Jalali-Farahani, N. Mostoufi, Steady-state And Dynamic Simulation Of The Process Of Extractive Distillation Of 1,3-butadiene From The C4-cut, in: V. Kachitvichyanukul, U. Purintrapiban, P. Utayopas (Eds.), *Proceedings of the 2005 International Conference on Simulation and Modeling*, 2005.
- [38] J. Schulze, M. Homann, Processes of Separation and Transformation in C4-Chemistry, in: *C4-Hydrocarbons and Derivatives*, Springer, Berlin Heidelberg, 1989, pp. 35–106, 10.1007/978-3-642-73858-6.4.
- [39] J. Schwarz, B. Beloff, E. Beaver, Use sustainability metrics to guide decision-making, *Chem. Eng. Prog.* 98 (7) (2002) 58–63.
- [40] R. Smith, *Chemical Process: Design and Integration*, John Wiley & Sons, 2005.
- [41] Stockburger, D., Volkamer, K., Bender, D., Schneider, K.-J., Schwentker, H., Wagner, U., Weitz, H.-M., & Durkheim, B. (1978). Separation Of A Mixture Of C4-hydrocarbons By Extractive Distillation (Patent No. US4162198A). <https://patents.google.com/patent/US4162198A/en>.
- [42] X. Tian, X. Zhang, L. Wei, S. Zeng, L. Huang, S. Zhang, Multi-scale simulation of the 1,3-butadiene extraction separation process with an ionic liquid additive, *Green Chem.* 12 (7) (2010) 1263–1273, <https://doi.org/10.1039/b918924f>.
- [43] N. Tripathi, Q. Xu, S. Palanki, Modeling and Simulation of the 1,3-Butadiene Extraction Process at Turndown Capacity, *Chem. Eng. Technol.* 42 (12) (2019) 2649–2657, <https://doi.org/10.1002/ceat.201900019>.
- [44] W.C. White, Butadiene production process overview, *Chem. Biol. Interact.* 166 (1–3) (2007) 10–14, <https://doi.org/10.1016/j.cb.2007.01.009>.
- [45] Y.C. Wu, P.H.C. Hsu, I.L. Chien, Critical assessment of the energy-saving potential of an extractive dividing-wall column, *Ind. Eng. Chem. Res.* 52 (15) (2013) 5384–5399, <https://doi.org/10.1021/ie3035898>.
- [46] X. Yang, X. Yin, P. Ouyang, Simulation of 1,3-Butadiene Production Process by Dimethylformamide Extractive Distillation, *Chin. J. Chem. Eng.* 17 (1) (2009) 27–35, [https://doi.org/10.1016/S1004-9541\(09\)60028-8](https://doi.org/10.1016/S1004-9541(09)60028-8).
- [47] J. Yu, S.J. Wang, K. Huang, Y. Yuan, H. Chen, L. Shi, Improving the Performance of Extractive Dividing-Wall Columns with Intermediate Heating, *Ind. Eng. Chem. Res.* 54 (10) (2015) 2709–2723, <https://doi.org/10.1021/ie503148t>.