

**Wave energy in the Netherlands
Past, present and future perspectives**

Lavidas, George; Polinder, Henk

Publication date

2019

Document Version

Final published version

Published in

Proceedings of the 13th European Wave Energy and Tidal Conference (EWTEC 2019)

Citation (APA)

Lavidas, G., & Polinder, H. (2019). Wave energy in the Netherlands: Past, present and future perspectives. In *Proceedings of the 13th European Wave Energy and Tidal Conference (EWTEC 2019)* Article 1226 EWTEC.

Important note

To cite this publication, please use the final published version (if applicable).
Please check the document version above.

Copyright

Other than for strictly personal use, it is not permitted to download, forward or distribute the text or part of it, without the consent of the author(s) and/or copyright holder(s), unless the work is under an open content license such as Creative Commons.

Takedown policy

Please contact us and provide details if you believe this document breaches copyrights.
We will remove access to the work immediately and investigate your claim.

Green Open Access added to TU Delft Institutional Repository

'You share, we take care!' - Taverne project

<https://www.openaccess.nl/en/you-share-we-take-care>

Otherwise as indicated in the copyright section: the publisher is the copyright holder of this work and the author uses the Dutch legislation to make this work public.

Wave energy in the Netherlands: Past, Present and Future perspectives

George Lavidas and Henk Polinder

Abstract—With the renewable targets of 2020 reaching ever closer, Europe is continuing its ambitious plans for 2030 of developing innovative projects that assist tackling climate change and increase renewable energy integration. The Netherlands are trying to develop their renewable energy portfolio, to create a viable long-term decarbonized sustainable society. So far majority of development has been focused on wind and solar, with offshore wind gaining significant traction over the past years. However, for the renewable energy transition to be fully realised, all indigenous resources must be evaluated and utilized.

The Netherlands have a long history of dealing with water, and have an extensive industrial base in ocean engineering and water infrastructure. However, when it comes to the development of wave energy the sector is lacking significantly compared to other offshore renewables. This study discusses the past, present and future status of wave energy in the Netherlands. We discuss the various schemes and propose a hybrid support scheme for the development of wave energy. Furthermore, we also consider the unique spatial characteristics of the coastlines and suggest a multi-zonal scheme, that can act beneficially and support development of different wave converter concepts.

Finally, based on the spatial and a techno-economic, we propose that by 2030 the policy focus should be to install up to 24 MW and by 2040 to 44 MW, with initial estimations on reductions per Unit Cost also discussed. With wave technologies in early stages of development in terms of technology and regional applications, there are numerous opportunities that can assist in “unlocking” the wave energy industry in the Netherlands.

Index Terms—Wave power, offshore energies, Learning rates, LCoE

I. INTRODUCTION

THE European Union (EU) has set ambitious targets in decarbonizing its energy mix increasing energy security, by the adoption renewable technologies [1]. Despite the 2008 economic turmoil interest in the development of innovative energy technologies and renewable energies has not diminished. In October 2018, the International Panel on Climate Change (IPCC) published a new report underlying the fact that CO_2 emissions are advised to decline by $\approx 20\%$ by 2030 from 2010 levels, and be reach net zero by 2075. To achieve these reductions, a complete overhaul and rapid transformation of energy systems is vital. Share

Submission ID: 1226 ESP. G. Lavidas receives funding for the project Wave Resource for Electrical Production (WAVREP) by the European Union’s Horizon 2020 research and innovation programme, under the Marie Skłodowska-Curie Individual Fellowship (MSCA-IF) grant agreement No 787344.

G. Lavidas, Mechanical, Maritime and Materials Engineering (3mE), Delft University of Technology (TU Delft), Mekelweg 2, 2628 CD Delft, The Netherlands (e-mail: G.Lavidas@tudelft.nl)

H. Polinder, Mechanical, Maritime and Materials Engineering (3mE), Delft University of Technology (TU Delft), Mekelweg 2, 2628 CD Delft, The Netherlands (e-mail: H.Polinder@tudelft.nl)

of renewables in electricity generation are suggested to be 27.95% for 2020 and $\approx 78\%$ in 2050 [2].

The Netherlands have signed the 2015 Conference of Parties (COP21) Agreement, and have committed in reducing their carbon emissions and increasing the renewable energy penetration. So far majority of renewable energy planning has been focused on solar and wind. Interest for large installations of offshore wind significantly increased, and led to the development of ambitious projects such as the North Sea Wind Power Hub [3]. The proposal is focused at delivering higher capacities in offshore wind aiming to reach a cumulative capacity of 230 GW by 2045, with the participation of countries exposed to the North Sea (i.e. Belgium, Netherlands, France, etc.). This translates into an annual installation of 10 GW [4]. However, such a large scale wind development will increase variable energy production and can create instabilities (i.e. power variations) in the electrical side, as such high levels of penetration by a stochastic resource decrease reliability and endanger the electricity grid.

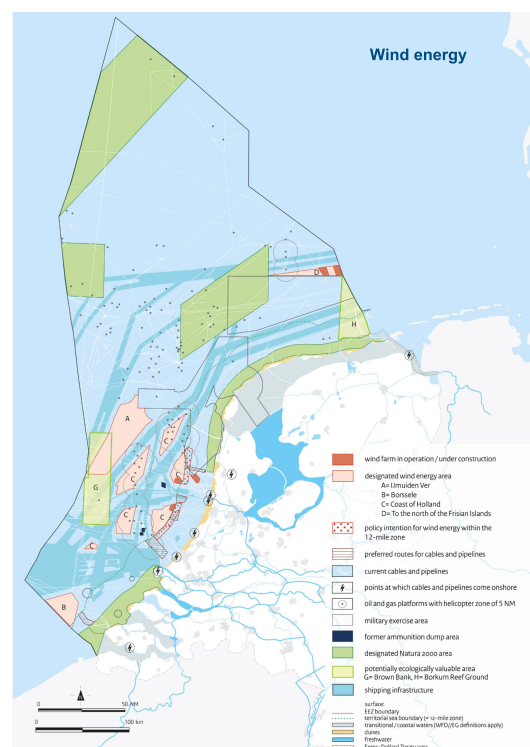

Fig. 1. Sea and coastal areas with indicative development plans and exclusion zones [5]

In Fig. 1 it is observable that marine and coastal areas around Netherlands are heavily characterized by protected and limited application areas (i.e. NATURA),

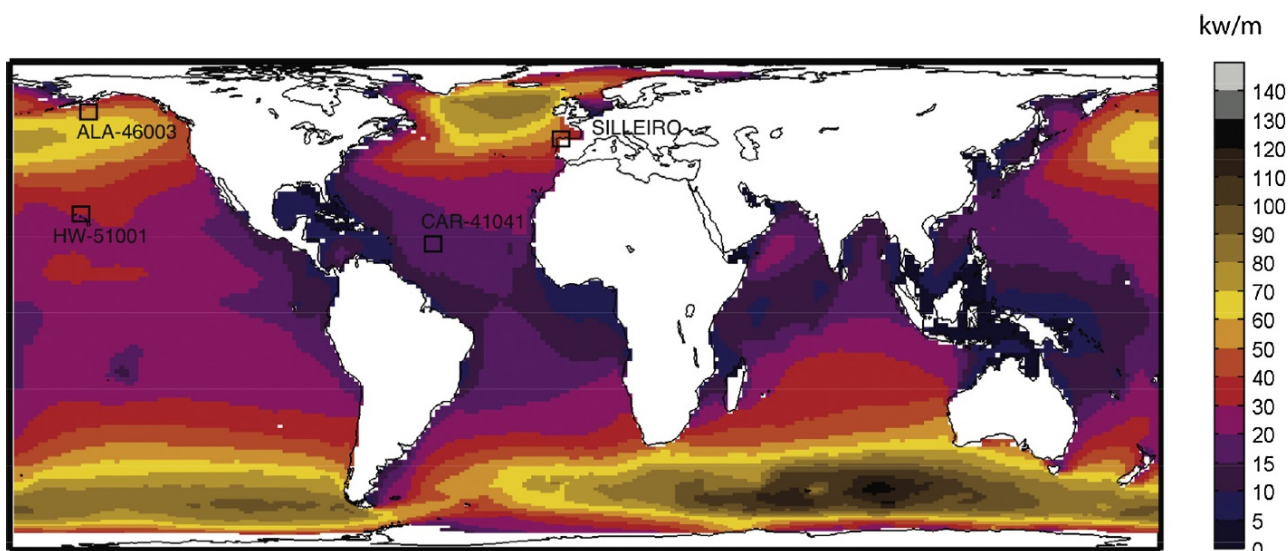

Fig. 2. Wave resource from a global hindcast (cite GOW2) [6]

and considering the congested space due to other anthropogenic activities; careful planning is required. One of the most under-utilised resources in the Netherlands is wave energy, this can be attributed to the difficulty of harnessing the resource that increases the cost of electricity. However, in order to avoid future catastrophes by extreme events the energy policy should consider tapping into all indigenous resources.

This work presents and discusses schemes for the promotion of innovative renewables as they have been used in other countries. Subsequently, we discuss a “new” approach for the development and revenue support of wave energy in the Netherlands. To date, the Netherlands have supported the development of a tidal project by TORCADO, at Oosterschelde in Eastern Scheldt, but wave energy still remains rather unexplored and under-utilise.

sectionThe Past

The wave resource in the Netherlands can be characterised as moderate to high, from 10-30 kW/m (at deeper waters). However, up to date no complete suitable hindcast assessment has been conducted to characterise the coastal regions of the Netherlands [7]. Therefore, we have to rely on large scale models [6], not suitable for regional energy resource assessments.

The Dutch have a historic precedent dealing with the harsh nature of waves, and have developed pioneering coastal works, but utilization of waves as an energy source is lacking. There has been activity in the Netherlands since 1995, regarding wave energy converters (WECs), with most successful development the Archimedes Wave Swing (AWS) [8], [9].

Unlike other European countries, that have set some level of compensation for wave energy, the Netherlands have not developed a detail policy-economic framework, although it has identified the Water Sector as the future of its International ambitions [10], [11]. Italy for example has a Feed-in-Tariff (FiT) system [12], while recently the United Kingdom established a Contracts-for-Difference (CfD) [13]. Based on such scheme the viability of a device can be assessed, how-

ever as discussed later on considerations concerning which measure is best varies.

II. THE PRESENT

Wave energy converters have been developing steadily over the past decade resulting in numerous devices. In the seminal review work of Falcao [14], technologies are classified according to working principles, i.e. the way they absorb the incoming energy by the waves, with their intricacies discussed in good detail.

Currently, in the Netherlands there are more tidal energy developers than wave energy developers [15]. This contrasts the potential of wave energy in the region over tidal. This discrepancy can be attributed to the fact that tidal has seen greater cost reduction faster than WECs, and Dutch programs are predominately focused in first funding was is more cost effective.

There is also a lack of information on the distribution of wave energy density in the Netherlands. However, the author is already in the process of delivering a long-term wave energy assessment later in 2019 [16]. The database will examine multi-decadal, annual, seasonal, monthly climate, waves and energy indicators. Recently, Dutch government has shown interest to support ocean energies, and is trying to position itself as a hub for development. There is discussion on the energy and techno-economic benefits of wave energy, as the knowledge of marine renewable energies is growing.

Even with lack of information and delayed initial support, there are several concepts developed by Small Medium Enterprises (SMEs), with different maturity and Technology Readiness Levels (TRLs). Some represent spin-off research ideas by Universities, attempts by well established wave energy experts, or newcomers in the field. This has allowed the generation of a very active and highly interested community for wave energy in the Netherlands.

A. SYMPHONY

The SYMPHONY WEC is developed by Teamwork Technologies. The technology has been built upon past experience by the developer, as the same had developed the Archimedes Wave Swing (AWS) which was installed as a full scale pilot plant in Portugal. The device is a submerged point absorber that moves along the water column, The small symphony (diameter = 1.5 m) moves with a stroke rate of 2m at only 20 cm waves. Resonance occurs since there is a spring inside the system. Range for cut-in operation is adjustable and the developers have also determined after examination the survivability mechanism. When waves are larger than a set threshold motion is damped and slows down until a complete halt, where the device [17].



Fig. 3. SYMPHONY concept [17]

B. S3 Wave Energy Converter

This WEC has been developing for over a decade at SBM offshore, and is based on a bulge operating principle. The WEC is a flexible tube that uses Electro-Active Polymers (EAP) as its Power-Take-Off (PTO) and generate electricity [18]. The tube has a (proposed) length of 200-400 meters and a diameter of 2-4 meters. As the water displaces volume inside the WEC, the EAP PTO harnesses elastic potential (mechanical) energy due to expansion [19].

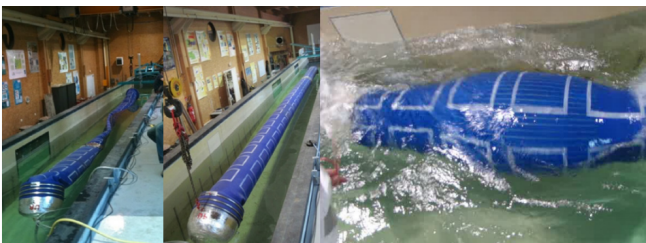

Fig. 4. SBM concept [19]

C. SlowMill

Slow Mill is a WEC consisting of a floater with blades variably connected to an anchor on the seabed, see Fig. 5. Waves push the floater up and the blades away from the anchor. This way not only the up and down but also the back and forth movements of the waves is

utilized. The blades go as deep as 4-5 m to extract wave power from below the surface as well [20].

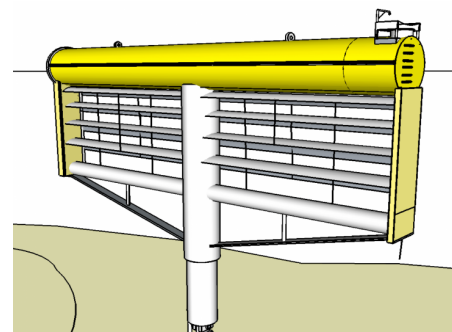

Fig. 5. Slowmill concept [20]

D. Ocean Grazer by University of Groningen

The Ocean Grazer is a concept developed by a start-up company at the University of Groningen, currently at its third iteration [21], [22]. It is a surface based device (point absorber) with a number of connected floaters, that form a "blanket" of continuous surface minimizing radiation effects, as the developers indicate.

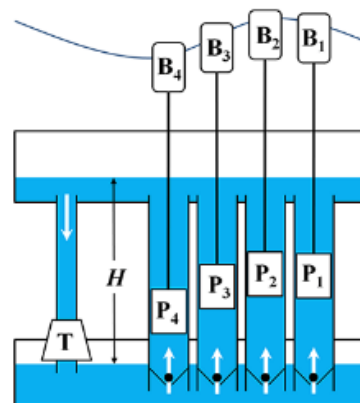

Fig. 6. Ocean Grazer concept and power take-off

III. THE FUTURE

One of the limiting factors that hinder wave energy, besides the cost of electricity (that can be dealt with), is the lack of convergence in design for WECs. This in turn has major ramifications on accelerating installation rates, developing common guidelines, and most importantly aligning the supply chain to cater for limited number of designs.

A positive attribute of the Dutch offshore environment, is that depth variations are "smoother", with no major applicability restrictions due to depth, but only because of distance from shore, see Fig. 7. In contrast for example to the Mediterranean where depth variations are much "sharper".

As seen in Fig. 1, only a small portion of coastlines is directly accessible at smaller depths. This direct zone

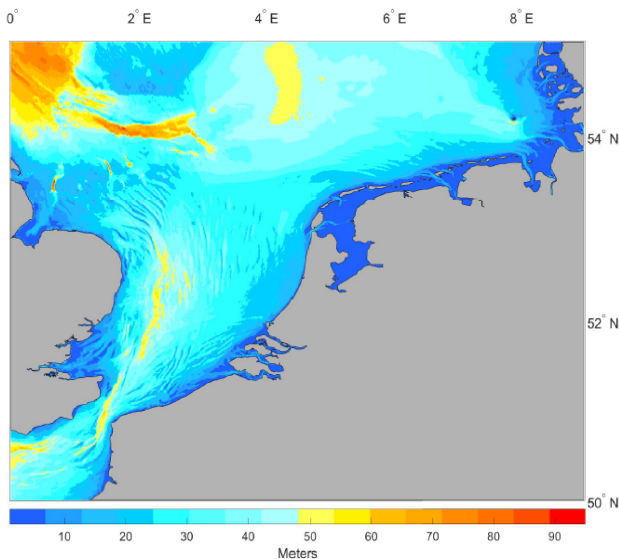

Fig. 7. Depth variation along the Netherlands

extends near entry at the Rotterdam Port until just under the Egmond aan Zee region (North Holland), spanning ≈ 110 Km of coastline, with depths from 5-30 meter with no sudden variations and multiple access point to the electrical grid. It has to be noted that all of coastal waters at depths ≥ 15 m are “free zones” for development, with some also being designated already as wind energy areas.

Wave energy is at the crossroads and needs quickly develop a working “proof”, the small gradients of depth allow for the consideration of multi-zonal WEC farms with different devices, based on alternate principles and ranges of operations. This will allow full utilization of incoming resources and can accelerate deployment efforts, whilst contributing to reduction of variability associated with renewables. As mentioned current effort of resource evaluation will address resources pre and post WEC farms deployment (not yet fully developed, expected mid 2019), as well as local environmental impact assessments, based on best practices and international guidelines.

IV. MARKET DEVELOPMENT

Regardless of device selected the financial elements of the project have to be assessed. The approach to first utilize the more “easily access” of the central belt (see Fig. 1) as the starting point, can be beneficial for reductions and/or limiting increases in Capital Expenditure (CapEx) and Operational Expenditures (OpEx). CapEx is dependent on a combination of local environmental characteristics and necessary works based on selected device (i.e. if coastal then more foundation required), the OpEx will benefit from the existing harbours and ease of access, even if a multi-zone approach is developed.

The combination of CapEx and OpEx, has an effect on indices used for energy projects such as Levelised Cost of Electricity (LCoE), and amortization/payback periods. Furthermore, these can also be reduced by development and gained experiences, similarly to the

sharp decreases in offshore wind, as a learning-by-doing approach.

For a potential multi-zonal deployment plan, selected devices must perform well at locations by increasing the extractable energy through matching the “newly altered” resource, see Fig. 8. This must not be associated only with the rated capacity, but also with device production reliability and survivability, as they are the main components that can assist in the reduction of LCoE.

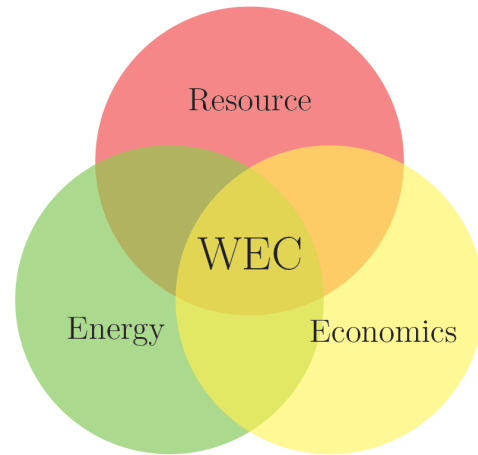

Fig. 8. Balances needed for successful development of wave energy converters (WECs)

The Netherlands do not have a mechanism to provide a revenue stream to WEC farms. Although, with the increasing need to transition into an carbon neutral, and even more ambitiously a negative system, some form of monetary compensation has to be put in place.

Consideration of multiple zones for offshore energies can increase synergies and spatial multi-uses, but as in any business venture, investment feasibility is crucial. There are two distinct ways that an energy project can get revenue, through market pull/push or a mixture of both.

Market pull and push are financial incentives provided by a policy framework through legislation. Pull strategies designed to provide a “steadier” and direct metric for the evaluation of economic feasibility and include measures such as Feed-in-Tariffs (FiT), Contracts for Difference (CfD), Spot Market Price (SMP). Market push are mechanisms aimed to offer additional revenue, or indirectly enhance economic considerations for development. Such measures can include tax exemptions, subsidies, energy origin certificates, emission credits etc. While the latter (market push) measures can provide significant incentives, a decision is usually based on market pull mechanisms, as projects rely more on them for revenue estimations over their lifetime.

Each market mechanism has different implications and sensitivities, in this work we examine FiT, CfD and ETS due to their wider usage in other European markets, and the possibility that they can be potential templates for a Dutch framework. A spot-market analysis is excluded due to the (current) lack of data of hourly production by WEC(s). Once resource

persistence is evaluated and regions with promising levels are suggested, a historical model can be used to assess spot-market price based on climate similarities, and energy production forecasting components can be examined more accurately.

Projected installation in this study are “technology blind”, i.e. we do not favour any particular device, but rather on past studies we investigate the sensitivities and implications on the economic factors affecting economic feasibility.

A. The Feed-in-Tariff (FiT)

An FiT it is a “simple” market pull mechanism and so far, has been very effective in the development of renewable energies. The revenue stream is guaranteed by the FiT, and often is adequate to cover a project’s capital expenditure (CapEx), operational/variable (VC_n), salvage costs (S) over the lifetime of a project, see Equation 1.

$$C_n = CapEx + VC_n - S \quad (1)$$

$$R_n = AEP \cdot c_o \cdot \left[\frac{1+e}{1+i} + \dots + \left(\frac{1+e}{1+i} \right)^n \right] \quad (2)$$

FiT revenues depend on the selling price of electricity (c_o), inflation (i), energy escalation rate (e), annual energy production (AEP) and year (n) [23], see Equation 2. The amortization period is determined by the point in time, when the sum of expected R_n matches and surpasses all costs (C_n) over the lifetime of a project. Depending on WEC(s) selected both CapEx and VC_n need re-calculation, therefore analysis must be done on a case by case basis.

Equation 2 depends highly on AEP and i that can alter the payback periods, from these two, i depends on macro-economic parameters, therefore the AEP can be “modified” based on optimal selection and/or design of a wave farm. It is common for R_n to be adjusted for inflation, but there have been cases (i.e. Germany FiT policies) that no adjustment was made ($e = 0$) leading to higher revenues in first years of operation, but these quickly phased off as inflation “caught up” and reduced the real monetary values [24].

FiT policies are geared towards creating an “artificial” demand for renewable electricity, providing with investors confidence can guarantee development. However, as the energy transition is moving forwards and most grids are “filling up” with large capacities of renewable energies, high guarantee prices create a deficit and distort energy markets. This can lead to increased energy prices, hence increasing retail and wholesale electricity prices. This element is often used by “opponents” of renewables, and argue that novel converters are and will be expensive for the system [25].

B. Levelized Cost of Electricity (LCoE)

Levelised Cost of Energy (LCoE) (see Eq. 3), is a metric often used in energy comparisons, and technology readiness levels [26], [27]. Allan et.al. [28] showed

that methods for LCoE estimations achieved similar results either with “Discounting” or “Annuitising”. First method discounts all investigated parts into current prices, while the latter uses an annuity formulation. Estimating the financial indices for every year at the corresponding discount annual rate. Dalton et.al. [26] noted that using LCoE for offshore energy is highly dependent on the selected discount rate, and most importantly on energy assumptions. However, LCoE carries inherit flaws based on assumption around economic indices [29] but most importantly AEP [26], [30].

$$LCoE_{tech} = \frac{\sum_{n=0}^n \frac{C_n}{(1+r)^n}}{\sum_{t=0}^n \frac{Prod}{(1+r)^n}} \quad (3)$$

with (r) the discounting rate, AEP is still the key parameter that ultimately determines the CoE/LCoE behaviour. While, LCoE is an indispensable tool as it provides a level field for comparisons with other technologies, it does not directly dictate the economic viability.

C. Contracts-for-Difference (CfD)

The United Kingdom (UK) has seen a staggering increase of renewables, both onshore and offshore. As in most countries, initial phases of development were supported by high FiTs, subsidies (market push) and as years progressed, it used tendering agreements and Renewable Obligation Certificates [31]. The latter were based technological maturing, for example of offshore wind 1.5 ROC/MWh are given, while wave energy was given 5 ROCs/MWh [32].

With wind (onshore & offshore) having surpassed expectations and having reached near fossil parity with LCoE 0.049 – 0.95 €/kWh [33], the supporting scheme had to be more competitive and change. Goal is to ensure lower price of electricity while at the same time keep the development of renewable energy and innovative technologies at high levels [34].

In this “new” scheme the operator provides a single reference selling price SP , that increased annually by a $e = 1.7-2\%$, it also provides a maximum Assigned Strike Price (ASP_{max}) per technology that cannot be exceeded. Technologies are separated in different “Pots” according to maturity levels, and ASP_{max} . The owner of a energy plant submits a Bidding Price (BP) (£/kWh) that has to be below ASP_{max} , but will also ensures viability.

Projects submitted are classified according to technology used, and are separated based on capacity and type. Pot 1 includes “established” technologies such as energy from waste, onshore wind ($P_o \geq 5$ MW), hydropower, solar ($P_o \geq 5$ MW), and landfill/sewage gas. In Pot 2 emerging technologies are included such as offshore wind, tidal stream, wave energy, biomass-geothermal (with or without CHP). Tidal and wave technologies are applicable in Pot 2 only if their P_o is ≤ 30 MW. In the case wave and tidal projects exceed this installed capacity then the maximum ASP proposed price are given by Equation 4.

$$BP = \frac{(300 \cdot 30) + ASP_{OW} \cdot (P_o - 30)}{P_o} \quad (4)$$

with ASP_{OW} being the ASP price for offshore wind the year as it is updated bi-annually after consultations, and P_o installed capacity over the $\geq 30MW$, see Equation 4.

The CfD scheme has a maximum (ASP) per technology, with SP for electricity as the “minimum” price. Every project can submit a new price BP as long as it is cheaper than ASP_{max} . Every project has to satisfy the criteria of price and a specified capacity, which are revised every year by the government. Projects are then compared with similar Pot type technologies, and their success depends on their competitiveness. Auction results showed a dramatic decrease in BP from 2015 to 2017 auctions $\approx 50\%$ for offshore wind [35], [36]. From sensitivity testing conducted by the first author, as part of a market report, it was found that for wave energy the CapEx must not exceed $6000\text{€}/kW$ and $P_o \leq 30 MW$.

D. Carbon Market

A Carbon Market has been envisaged since inception of the Kyoto Protocol, but there have been difficulties mainly with setting a price for emissions. The Emissions Trading Scheme (ETS) is based on a capped policy that favours “greener” solutions with increases in emissions market prices, by annual imposing emission restrictions (reducing allowed emissions). Currently ETS is at its third phase, that foresees a decrease in permitted allowances for power/industrial installations, transport and aviation.

The ETS scheme in recent years has been successful, and has assisted in the development of programs to promote “cleaner” technologies, namely the New Entrance Reserve (NER300) [37]. Although, it was expected that NER300 would obtain 4.5 billion €, it only accrued just over 2.1 billion € from a two round call. This was in part due to the unforeseen low carbon (CO_2) price. Since conclusion of NER300, the price for CO_2 has seen a dramatic increase from $\approx 5 \text{€}/\text{Tn } CO_2$ (2013 price) to near $25 \text{€}/\text{Tn } CO_2$, a fivefold increase, see Fig. 9. Estimates are expecting the barrier of $35 \text{€}/\text{Tn } CO_2$ to be exceeded soon, and the future values by 2030 to be $\geq 60 - 80 \text{€}/\text{Tn } CO_2$.

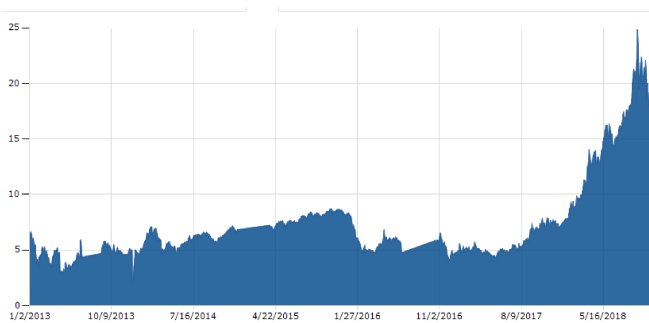

Fig. 9. CO_2 European Emission Allowances (€) [38]

The 2.2 billion € gathered from the NER300 were given to numerous “clean” projects, with Ocean energies being awarded 6.44%. Wave projects only got a 0.07% (or 14% of the 6.44% funds for Ocean Energies),

this represents a very small part given the potential that wave energy has in terms of applicability, growth, and emissions reduction. We argue that wave energy projects, should be able to access and sell their avoided CO_2 in the ETS market as they can yield significant avoided CO_2 emissions [39]. Building upon that, to ensure enhancement of innovative technologies, a merit order scheme should also prioritize less mature solutions.

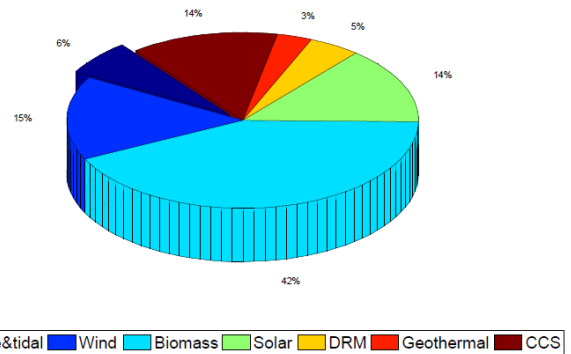

Fig. 10. NER300 allocated total funds (≈ 2.2 billion €) breakdown

E. Learning Rates (LR) and Experience Curves (EC)

A zonal approach will allow for more WECs to be considered, with ideally converging to 3-5 designs that are suited for different depths. The North Sea is an excellent “test site” for spearheading such a development, with many surrounding nations sharing access and pursuing WEC developments. The zonal approach should be broken down in 3 depths, shallow ($5 \leq d \leq 30$ m), nearshore ($30 \leq d \leq 50$ m), deep ($50 \leq d \leq 100$ m).

Multi-separation will also have positive effects on estimating potential WEC deployments for up to 2040 or even further. Without, a multi depth zonal approach available coastal front in the Netherlands, that is not Natura is ≈ 105 Km. This can be a limitation for the development WEC farms if we only consider placing them directly to incident incoming resource. The opportunity that exists in a zonal solution, is due to the large number of WECs that cater to different principles of operation. However, through proper resource assessment, zonal deployments, estimation of wake effects and their minimisation we can potentially achieve three time the development, and potential reach a greater LCoE reduction (for some WECs).

Learning rates (LR) is a method that can be used to provide estimations and extrapolate future cumulative installations, and subsequently cost reduction through a “learning-by-doing” approach.

$$P_t = P_0 \cdot \left(\frac{x_n}{x_0} \right)^{-b} \quad (5)$$

$$LR = 1 - 2^{-b} \quad (6)$$

LR is estimated with a single factor function aimed to reduce the uncertainty of assumptions, see (Equation 5). Where x_0 cumulative capacity at starting time, P_0

cost of unit produced at initial time, x_t is the cumulative capacity at time (t), P_t is cost of unit produced at time (n), and b is the learning parameter which is estimated by the LR (Equation 6). As mentioned previously the Netherlands do not have a suitable resource assessment, however from larger and other regional studies, it can be classified as moderate to high with expected levels from 10-30 kW/m at deployable depths.

The “traditional” estimation of LR assumes that each year the installations will double their installed capacities. The estimates start at 2019 with a horizon up to 2040, and an increment of 1 MW/year (Low), 2 MW/year (Medium) and a “pure doubling” MW/year.

Considering that WEC farms want to achieve deployments in a well developed field, the renewable energy field, we have to reduce our expected assumptions. Such LR will be more applicable after the first MW are installed. As discussed in Lavidas [40], it is more appropriate to use an annual set incremental target to develop wave energy farms. Therefore, we assume an initial x_0 at 2 MW, with cost at P_0 5 million €/MW, with b set at 0.12 slightly lower than other studies as we consider a mix of WEC technologies at least shallow and nearshore. Finally, accepted WEC considered should at least have a capacity factor of 20% in order to be competitive with other renewables, i.e. photovoltaic.

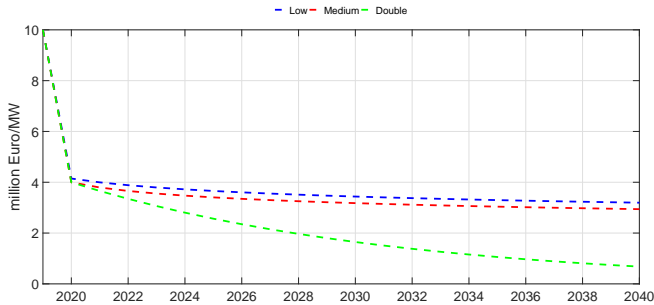

Fig. 11. Reduction per unit cost achieved by different annual rates of installation

Given the sensitivity chosen reduction of cost (€/MW) is directly associated with cumulative installations, see Fig. 11. Due to the fact that we considered a starting WEC farm at 2 MW, the cost reduction even with Low scenario is significant, this can be traced to the short-term effects that a high starting capacity have; combined with the near “double” for the first year increment rate. In terms of cumulative MW capacities in 2030 the Low scenario indicates 13 MW, the High 24 MW, and the Double \approx 4 GW. From existing experiences in the sector [41], it is safe to assume that the Double scenario will not be feasible for the 1st generation wave farms. For 2040 cumulative capacities amount to 23 MW and 44 MW, for Low and High respectively. Focusing on the most probable Unit costs for 2030 can be 3.4 m€/MW (Low) 3.1 €/MW (High), and for 2040 3.1 m€/MW (Low) and 2.9 m€/MW (High).

V. DISCUSSION & FUTURE WORK

The complexity of the wave resource, leaves lots of room for maneuvering when it comes to design techno-economic solutions and policies. Energy considerations on wave deployments should also account for depth applicability, and resource alterations. This means that while allowed space for offshore developments is limited, different zones of wave energy growth can be assigned in accordance to depth. Even in this case convergence is needed, and will be vital to narrow potential WECs according to depth and a “resource-to-production” approach pre and post every suggested solution.

Several different depth deployment zones can be considered, therefore a limited “spatial” domain can be used and prove beneficial in the multi-selection of different devices based on applicability. This approach will have effects on the selection of suitable devices, which through convergence will limit potential candidates.

The North Sea depth and fetch characteristics allow for unique development proposals. When considering for 1st generation farm, we have to ensure that connection points are close, so as to avoid unnecessary expenditure that can increase CapEx. First generation farms can be directly situated at shallow to nearshore regions (depths=5-30 m), but their placements should not exclude further consideration for WECs. Due to the slow changes in the gradients of bathymetry, in relatively close spaces more WECs, suitable for different depths i.e. nearshore (depths= 30-50 m). This zonal approach will not only benefit in obtaining better learning rates and reducing €/MW, LCoE but it will also be a hub for grid connection “expense sharing” and accelerate the “proof-of-concept” for WECs.

WECs will have different viability under different schemes, in FiTs dependence is more on C_n and inflation, similarly for LCoE CapEx and inflation are major drivers. For the CfD major dependencies are on the installed capacities and CapEx. In all cases AEP estimation dictates produced energy and thus a WEC selection should consider location characteristics. AEP estimates should always use comprehensive and suitable metocean data

LCoE is used as an indicator, and it has no direct effects on financial survivability for wave energy farms. Indirectly, it shows the comparison to other sources of energy, but this can often provide a distorted picture by favouring established technologies. However, the importance of LCoE as an initial metric should be retained, but projects that are near the so-called “point of commercialization” (some argue around 250-300 €/MWh) should conduct a detail cost benefit analysis, accounting also for avoided emission and reduction of variability in a renewable energy system, as they will have positively LCoE implication.

However, LCoE also depends on energy production capabilities of the WEC(s), several authors have argued that a targeted re-scale of converters can achieve major improvements in the availability, power production of a device [42], [43]. Whilst at the same time reduce

the materials needed, and therefore the CapEx due to lower extreme conditions. Re-designing and tuning the devices is feasible, though it will require developers working with suitable long-term resource data to maximise operation. Considering the wave resource of the Netherlands, maturity and “depth” of industrial base, it is advisable that the initial Dutch wave energy development scheme is given a “hybrid approach”.

With the disparity of WECs, the national scheme should encourage devices suited to milder resource, therefore assuring that AEP is optimised while CapEx is kept low. As we have to consider the electricity sector as a whole, an upper limit price must be given, however some level of guaranteed is also needed still. For innovative projects WEC farm, the potential scheme should also tap into the ETS and allow for developers to rip the benefits of avoided emissions and obtain additional revenue. The “hybrid” system will be based on a guaranteed FiT, with merit order access to grid and allowances.

Currently the authors are working on the techno-economic of such a policy recommendation specifically to determine FiT viability, with a price floor for WEC developers and price ceiling for the government. This is done by first quantifying and mapping the resource, optimising WECs, components and connections. Our aim is to provide a realistic “value-for-money” that will enhance the wave energy as a viable business proposal, that does not rely solely on generous “one-off” schemes.

The wave energy sector has major intricacies that must be overcome, but the potentials for contribution in energy and growth are major. The sector has to build upon existing solutions that cater to the energy macro-economic sector, as wave energy is a part of a larger market.

ACKNOWLEDGEMENT

The authors would like to thank the anonymous reviewers for their constructive comments, that helped improve the manuscript.

REFERENCES

- [1] E. Parliament, “The European Parliament. Directive of the European Parliament and of the Council on the promotion of the use of energy from renewable sources amending and subsequently repealing directives 2001/77/ec and 2003/30/ec.” Tech. Rep., 2009.
- [2] IPCC, “Global warming of 1.5°C, an ipcc special report on the impacts of global warming of 1.5°C above pre-industrial levels and related global greenhouse gas emission pathways, in the context of strengthening the global response to the threat of climate change, sustainable development, and efforts to eradicate poverty,” Accessed on 8-11-2018. [Online]. Available: <http://www.ipcc.ch/report/sr15/>
- [3] Tennet, “North sea wind power hub,” 2018, Accessed on 8-11-2018. [Online]. Available: <https://www.tennet.eu/our-key-tasks/innovations/north-sea-wind-power-hub/>
- [4] ECOFYS, “Translate cop21 2045 outlook and implications for offshore wind in the north seas,” 2017. [Online]. Available: <https://www.ecofys.com/files/files/ecofys-2017-translate-cop21-offshore-wind-north-seas.pdf>
- [5] Noordzeeloket, “Offshore wind energy areas,” 2018, Accessed on 8-11-2018. [Online]. Available: <https://www.noordzeeloket.nl/en/functions-and-use/offshore-wind-energy/gebieden/>
- [6] J. Perez, M. Menendez, and I. J. Losada, “GOW2: A global wave hindcast for coastal applications,” *Coastal Engineering*, vol. 124, no. March, pp. 1–11, 2017. [Online]. Available: <http://dx.doi.org/10.1016/j.coastaleng.2017.03.005>
- [7] G. Lavidas and V. Venugopal, “Application of numerical wave models at European coastlines : A review,” *Renewable and Sustainable Energy Reviews*, vol. 92, no. October 2016, pp. 489–500, 2018. [Online]. Available: <https://doi.org/10.1016/j.rser.2018.04.112>
- [8] H. Polinder, M. E. C. Damen, and F. Gardner, “Linear pm generator system for wave energy conversion in the aws,” *IEEE Transactions on Energy Conversion*, vol. 19, no. 3, pp. 583–589, Sept 2004.
- [9] EUREKA, “Archimedes wave swing (aws): energy out of waves,” 2018, Accessed on 9-11-2018. [Online]. Available: <http://www.eurekanetwork.org/project/id/1219>
- [10] P. Scheijgrond and A. Raventos, “Tki wind op zee, dutch wave & tidal energy sector: Status, challenges and roadmap,” Tech. Rep., 2015.
- [11] P. Scheijgrond and C. Nieland, “International ambitions of the dutch energy from water sector,” Tech. Rep., 2016.
- [12] GSE, “Gestore Servizi Energetici,” 2015. [Online]. Available: <http://www.gse.it/en/qualificationandcertificates/Theall-inclusivefeed-intariff/Pages/default.aspx>
- [13] DECC (Department of Energy and Climate Change), “Electricity Market Reform (EMR) Annual Update,” Department of Energy & Climate Change, Tech. Rep., 2015.
- [14] A. F. D. O. Falcão, “Wave energy utilization: A review of the technologies,” *Renewable and Sustainable Energy Reviews*, vol. 14, no. 3, pp. 899–918, apr 2010. [Online]. Available: <http://linkinghub.elsevier.com/retrieve/pii/S1364032109002652>
- [15] D. Magagna, R. Monfardini, and A. Uihlein, “JRC Ocean Energy Status Report,” Tech. Rep., 2016. [Online]. Available: <http://publications.europa.eu/en/publication-detail/-/publication/e22b8458-f412-11e6-8a35-01aa75ed71a1/language-en>
- [16] G. Lavidas, “Wave resource for electrical production (wavrep), msca-if 2017, european commission,” 2018, Accessed on 8-11-2018. [Online]. Available: https://cordis.europa.eu/project/rcn/213948_en.html
- [17] “Teamwork technologies, symphony wave power,” 2018, Accessed on 8-11-2018. [Online]. Available: <https://symphonywavepower.com/how-does-it-work/>
- [18] “Sbm offshore, renewable energy,” 2018, Accessed on 19-11-2018. [Online]. Available: <https://www.sbmoffshore.com/what-we-do/our-products/renewables/>
- [19] “Sbm offshore, wave energy converter concept development,” 2018, Accessed on 19-11-2018. [Online]. Available: <https://www.sbmoffshore.com/wp-content/uploads/2016/06/Technology-Wave-Energy-Converter-FINAL-LOW-RESOLUTION.pdf>
- [20] SlowMill, “Slow mill,” 2018, Accessed on 8-11-2018. [Online]. Available: <http://www.slowmill.nl/>
- [21] OceanGrazer3.0, 2018, Accessed on 8-11-2018. [Online]. Available: <http://www.oceangrazer.com/>
- [22] OceanGrazer, “Oceangrazer: Previous iteration.”
- [23] T. D. Couture, K. Cory, C. Kreycik, and E. Williams, “Policy-maker’s guide to feed-in tariff policy design.”
- [24] T. Couture and Y. Gagnon, “An analysis of feed-in tariff remuneration models: Implications for renewable energy investment,” *Energy Policy*, vol. 38, no. 2, pp. 955 – 965, 2010. [Online]. Available: <http://www.sciencedirect.com/science/article/pii/S0301421509007940>
- [25] J. A. Lesser and X. Su, “Design of an economically efficient feed-in tariff structure for renewable energy development,” *Energy Policy*, vol. 36, no. 3, pp. 981 – 990, 2008. [Online]. Available: <http://www.sciencedirect.com/science/article/pii/S0301421507004983>
- [26] G. Dalton, G. Allan, N. Beaumont, A. Georgakaki, N. Hacking, T. Hooper, S. Kerr, A. M. O’Hagan, K. Reilly, P. Ricci, W. Sheng, and T. Stallard, “Economic and socio-economic assessment methods for ocean renewable energy: Public and private perspectives,” *Renewable and Sustainable Energy Reviews*, vol. 45, pp. 850–878, 2015. [Online]. Available: <http://linkinghub.elsevier.com/retrieve/pii/S1364032115000787>
- [27] R. Guanache, a. D. de Andrés, P. D. Simal, C. Vidal, and I. J. Losada, “Uncertainty analysis of wave energy farms financial indicators,” *Renewable Energy*, vol. 68, pp. 570–580, 2014. [Online]. Available: <http://dx.doi.org/10.1016/j.renene.2014.02.046>
- [28] G. Allan, M. Gilmartin, P. McGregor, and K. Swales, “Levelised costs of Wave and Tidal energy in the UK: Cost competitiveness and the importance of “banded” renewables

- obligation certificates," *Energy Policy*, vol. 39, no. 1, pp. 23–39, 2011. [Online]. Available: <http://dx.doi.org/10.1016/j.enpol.2010.08.029>
- [29] C. Siddons, G. Allan, and S. McIntyre, "How accurate are forecasts of costs of energy? A methodological contribution," *Energy Policy*, vol. 87, pp. 224–228, 2015. [Online]. Available: <http://linkinghub.elsevier.com/retrieve/pii/S0301421515301026>
- [30] E. B. Mackay, A. S. Bahaj, and P. G. Challenor, "Uncertainty in wave energy resource assessment. Part 1: Historic data," *Renewable Energy*, vol. 35, no. 8, pp. 1792–1808, 2010. [Online]. Available: <http://dx.doi.org/10.1016/j.renene.2009.10.026>
- [31] Z. Abdmouleh, R. a.M. Alammari, and A. Gastli, "Review of policies encouraging renewable energy integration & best practices," *Renewable and Sustainable Energy Reviews*, vol. 45, pp. 249–262, 2015. [Online]. Available: <http://linkinghub.elsevier.com/retrieve/pii/S1364032115000453>
- [32] G. Lavidas, *Wave Energy Resource Modelling and Energy Pattern Identification Using a Spectral Wave Model*, doctor of ed., Edinburgh, 2016. [Online]. Available: <https://www.era.lib.ed.ac.uk/handle/1842/25506>
- [33] E. S. Rubin, I. M. Azevedo, P. Jaramillo, and S. Yeh, "A review of learning rates for electricity supply technologies," *Energy Policy*, vol. 86, pp. 198–218, 2015. [Online]. Available: <http://linkinghub.elsevier.com/retrieve/pii/S0301421515002293>
- [34] WindEurope, "Record-low bids in offshore wind should make policy makers rethink post-2020 ambition levels," 2018, Accessed on 9-11-2018. [Online]. Available: <https://windeurope.org/newsroom/news/record-low-bids-in-offshore-wind-should-make-policy-makers-rethink-post-2020-ambition-levels>
- [35] UKgovernment, "Contracts for difference (cfd) allocation round one outcome," 2018, Accessed on 9-11-2018. [Online]. Available: https://assets.publishing.service.gov.uk/government/uploads/system/uploads/attachment_data/file/407059/Contracts_for_Difference_-_Auction_Results_-_Official_Statistics.pdf
- [36] —, "Contracts for difference second allocation round results," 2018, Accessed on 9-11-2018. [Online]. Available: https://assets.publishing.service.gov.uk/government/uploads/system/uploads/attachment_data/file/643560/CFD_allocation_round_2_outcome_FINAL.pdf
- [37] European Commission, "NER300," 2018, Accessed on 9-11-2018. [Online]. Available: <http://ec.europa.eu/clima/funding/ner300-1/index/en.htm>
- [38] BusinessInsider, "Commodities, co2 european emission allowances in eur - historical prices," 2018, Accessed on 9-11-2018. [Online]. Available: https://markets.businessinsider.com/commodities/historical-prices/co2-emissionsrechte/euro/1.1.2013_7.11.2018
- [39] G. Lavidas, "Developments of energy in EU – unlocking the wave energy potential," *International Journal of Sustainable Energy*, vol. 0, no. 0, pp. 1–19, 2018. [Online]. Available: <https://doi.org/10.1080/14786451.2018.1492578>
- [40] —, "Energy and socio-economic benefits from the development of wave energy in Greece," *Renewable Energy*, vol. 132, pp. 1290–1300, 2019. [Online]. Available: <https://doi.org/10.1016/j.renene.2018.09.007>
- [41] OES, "International Levelised Cost Of Energy for Ocean Energy Technologies," Tech. Rep. May, 2015.
- [42] C. Luppa, L. Cavallaro, E. Foti, and D. Vicinanza, "Potential wave energy production by different wave energy converters around Sicily," *Journal of Renewable and Sustainable Energy*, vol. 7, no. 6, p. 061701, 2015. [Online]. Available: <http://scitation.aip.org/content/aip/journal/jrse/7/6/10.1063/1.4936397>
- [43] G. Lavidas and V. Venugopal, "A 35 year high-resolution wave atlas for nearshore energy production and economics at the Aegean Sea," *Renewable Energy*, vol. 103, pp. 401–417, 2017. [Online]. Available: <https://doi.org/10.1016/j.renene.2016.11.055>